

Truck Tire Spreader

Instruction Manual



WARNINGS

- ◆ Please read the instruction booklet and all the directions listed on the sticker attached on the machine carefully and fully understand the contents before use, which is necessary for protecting the users from harms and the machine from damages.

- ◆ This machine is used for spreading tires or repairing protective casing of tires only. It can't be used for other applications. Our company will not accept any responsibilities for all the consequences due to improper use.
- ◆ Keep the spreading hooks and claws clean in the process of spreading, to avoid sliding due to grease or some other foreign objects, which will bring danger to the maintenance work.

- ◆ Please don't use the machine when it obviously appears too old or when it is clearly twisted out of shape or when it's damaged, and make treatment in accordance with the local laws and regulations of waste management.

- ◆ The professionals that operate the machine should wear suitable protective ocular coverings in a correct way throughout, to protect the eyes from harms caused by the sundries in the process of repairing.

Product Illumination

Horizontal pneumatic car tire spreader special design for fixed the tires and spreading the tires during repairing cars and small trucks, microbus, in order to work for the tire polishing, cleaning and films affixed etc, equipped with work light and tools rack to improve work efficiency, enable the tire repairing work to be more convenient and faster. Manifest personalized design.

Technical Parameter

Be propitious to:

tire type: 8.25-20/14.00-20(9R-16.5R);R22.5

Work Voltage:

Input voltage: 220V 50/60HZ

Work light voltage: 12V

Air pressure:: 8-10 KG/CM²

Product structure Illumination

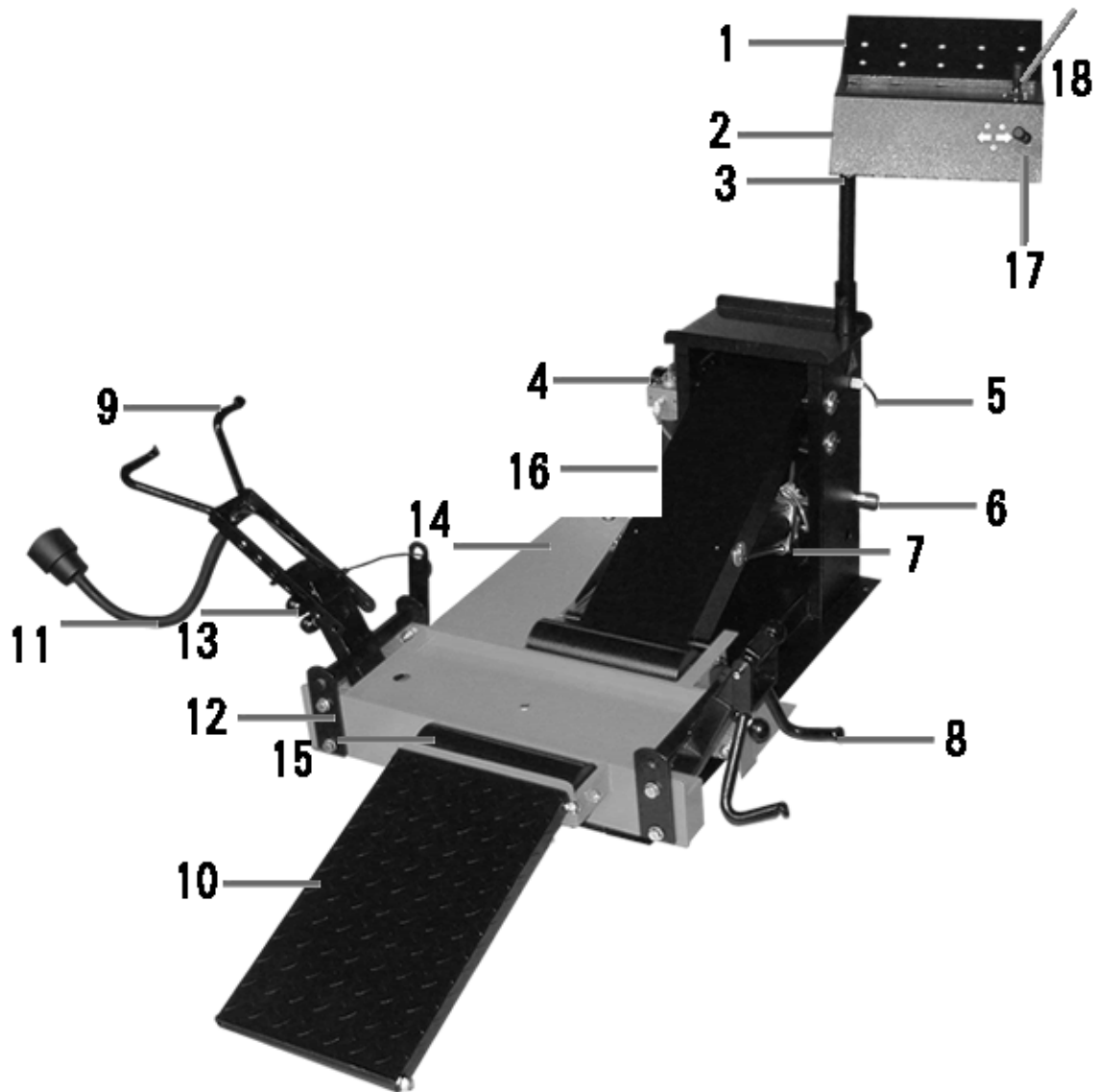

- (1) Tools Tray (2) pneumatic control box (3) tools racks
(4) Air Regulator Device (5) main body Power
(6) Pneumatic union (7) up &down pneumatic cylinder
(8) Short spread hook (9) Long spread hook
(10) Tire platform (11) Work light
(12) up &down platform (13) Adjusting valve
(14) Spread pneumatic cylinder (15) Tire lever
(16) Pneumatic tools union
(17) Spread pneumatic cylinder control valve
(18) Up &down pneumatic cylinder control valve

INSTALLATION

1. Place this product on solid ground and keep its flat
2. Remove the backboard of pneumatic control box from the inclined support board



3. Take the fixed pin from the pneumatic control box

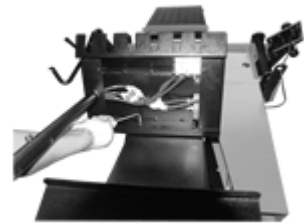

4. Put the pneumatic control box on the top of body box and adjust well the position



5. Connect the tools tray with pneumatic control box well



6. Connect the tire sloping board with equipments well



7. Connect the spread hook which equipped with work light with equipments well



8. Connect the short spread hook with equipments



9. Connect a fast joint top at 1/4 normal temperature and moderate air pressure onto the fast joint top of the machine's air inlet. The minimum standard is to use 1/4 inch's wind pipe every 100 square inches.



10. Fixed it on the flatly ground with screws and keep the screw firmness

Operation

1. Before start the machine, check carefully whether the fasteners on the machine are loose or not because of transportation. If yesterday, must be re-tightened.
2. Fix the tire on the tire spreader with claw by hand



3. According to the size of tire which need be repaired to adjust the spreading claw to be the appropriate height. Place the spreading hook to be link pin of the hanging device. Adjust the spreading hook, move the link pin and spreading hook up and town in order to insert into one of adjusting holes which totally have seven groups. Put the short spread hook inside the tire and try to place the tire in the middle of tire lever if possible



4. Pull the spreading control valve to the direction of spreading, and spread the tire to the width needed. The tire will probably disengage from the spreader if the spreading hook arm is too high. Operate after it is lowered and the height is properly adjusted.



5. Pull the up&down control valve to the direction of up&down needed, raise the tire to a proper height.

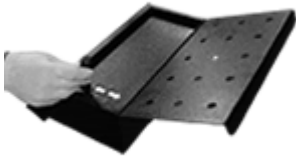

6. If it's needed to revolve the tire to a new position, please pull the spreading control valve to the direction of contraction, revolve the tire to a proper position on the machine after the spreading hooks are loosened, then operate the machine.



7. The working light fixed on the machine needed to be adjusted to a proper position, to illuminate the inside sufficiently and make the repair work easy.



8. After finished maintenance work, please firstly move the up&down control valve to the downward direction, let the tire fall to the lowest, then move the up&down control valve to the direction of contraction, loosen the spreading hook and remove it from the tire core, then discharge the tire along the sloping board.

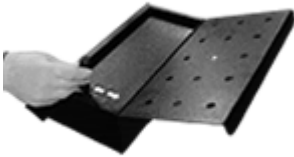

Maintenance

- ◆ Add the lubrication oil to the oil cup in time, always guarantee that the oil quantity in the cup to be occupy $1/3$ - $2/3$ of the total volume. Adjust drip oil speed, piston reciprocating run every 5 ~ 6 times for drip one blob oil for standard. ensure the oil pathway lubricate fully.
- ◆ clear away the dust and sundries always, check whether the fastener is loose or not.
- ◆ Drip oil to the piston rod and the various parts of pin regularly. Reducing friction, extending machine life.

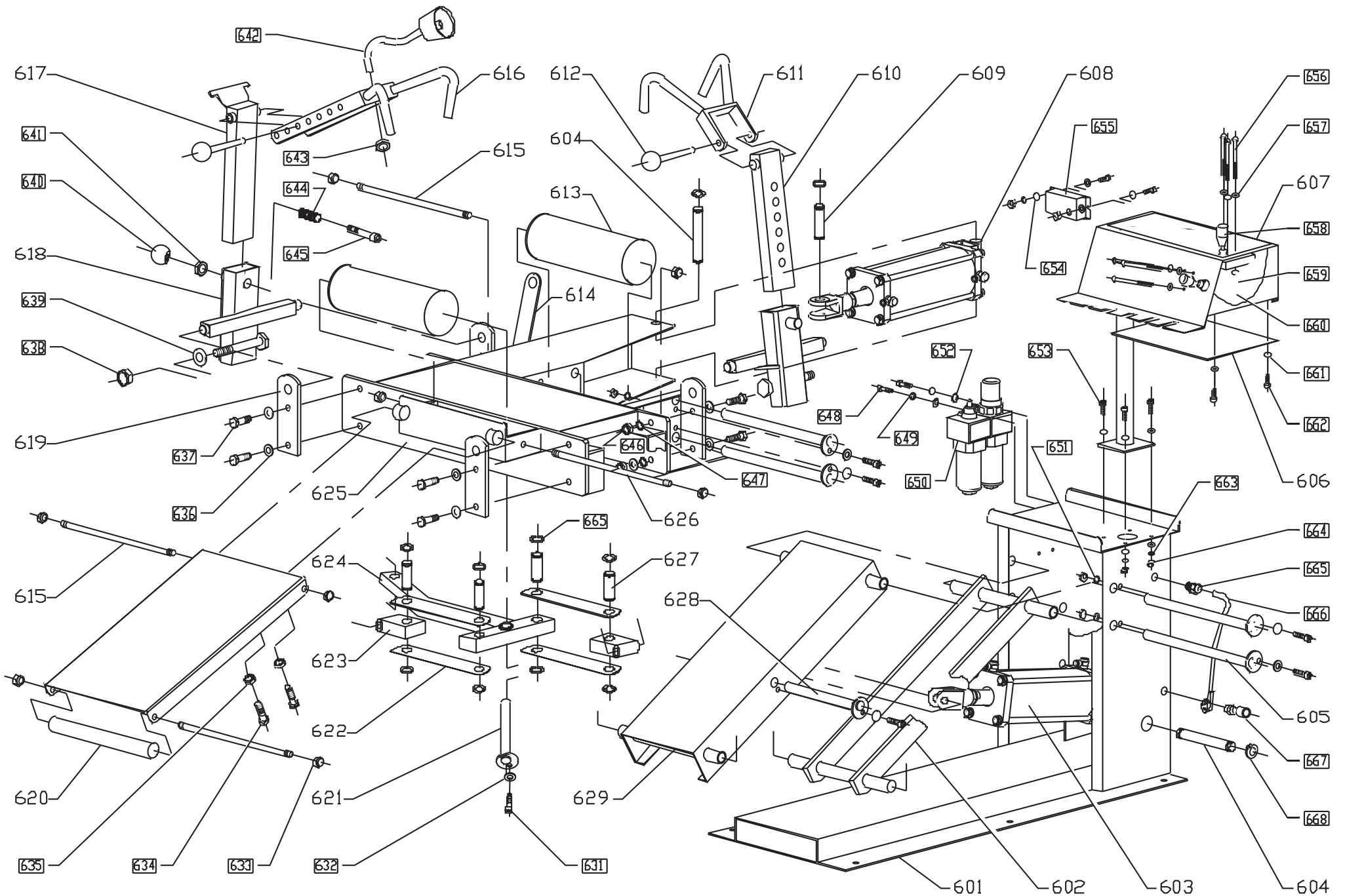

Body Assembly

NO	CODE	description	quantity
601	110000	body	1
602	130000	swinging frame	1
603	140000	up pneumatic cylinder	1
604	200004	pneumatic cylinder shaft	2
605	150001	shaft 1	4
606	160007	Motherboard of pneumatic control box	1
607	160000	pneumatic control box	1
608	170000	spreading pneumatic cylinder	1
609	200010	connecting union	1
610	240001	Adjustive pipe 1	1
611	250000	short spread hook	1
612	200007	Alignment unite element	2
613	290000	lever unite element	2
614	200005	Power line bracket	1
615	200008	Staff shaft	3
616	260000	Long spread hook	1
617	240000-2	Adjustive pipe 2	1
618	230000	swing frame	2
619	200002	branch union	4
620	222000	lever unite element	1
621	150000-3	Shaft 3	1
622	200001	connection board	4
623	280000	short pulling pole	2
624	270000	pulling pole	1
625	210000	Up & down bracket	1
626	200009	Shaft 2	1
627	200003	Connecting-rod shaft	4
628	150000-2	Shaft 2	1
629	120000	swing cover	1
630	160008	tools tray	1
631		Column hexangular bolt M8X10	6
632		washer 8	6
633		ceasing nut M12	8
634		Hexangular bolt M8X30	2
635		Hexangular nut M8	7
636		washer 12	12
637		Hexangular bolt M12X40	8
638		ceasing nut M16	2
639		washer 16	2
640		handle ball B-M10X32	2
641		Coarse thread Hexangular flat bolt M10	2
642		work light	1
643		Hexangular flat bolt M10	1
644		compressing spring	2
645		Column hexangular bolt M10X50	2
646		Hexangular nut M12	8
647		spring washer 12	2

NO	CODE	description	quantity
648		Column hexangular bolt M6X12	4
649		spring washer 6	2
650		air regulator	1
651		spring washer 8	5
652		big flat washer 6	2
653		Column hexangular bolt M5X16	2
654		big flat washer 5	2
655		electron transformer	1
656		crossed set bolt M4X40	6
657		washer 4	12
658		handle valve	2
659		spring washer 4	6
660		Hexangular nut M4	6
661		washer 5	12
662		Column hexangular bolt M5X10	4
663		spring washer 5	2
664		Hexangular nut M5	2
665		loop	1
666		power thread	1
667		metal quick connector	1
668		shaft spring loop 20	14
669		washer 6	4
670		Hexangular nut M6	2
671		Column hexangular bolt M8X12	1

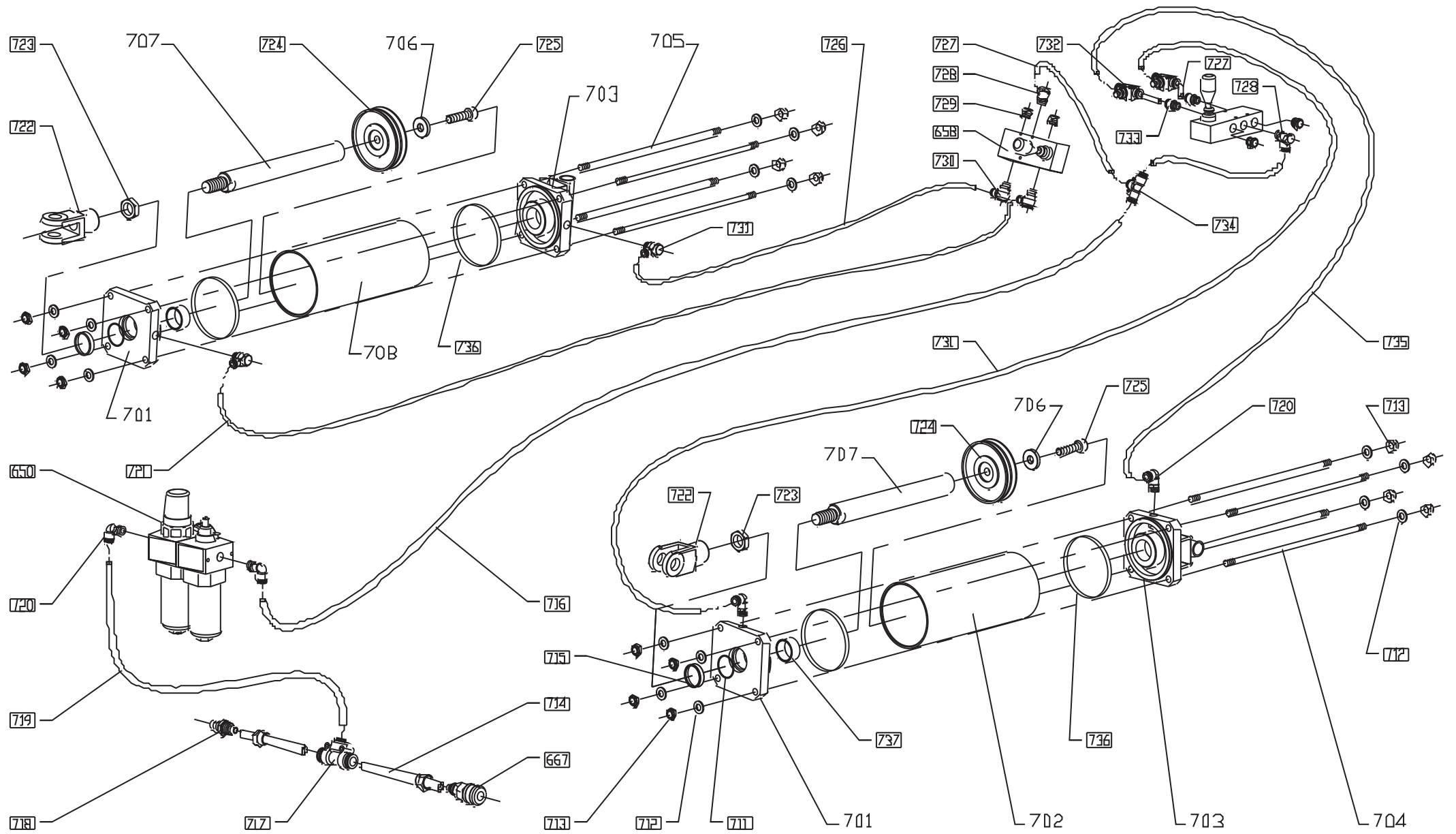

Pneumatics Assembly

NO	CODE	description	quantity
667		metal quick connector	1
701	140005	pneumatic cylinder cover	2
702	140003	pneumatic cylinder canister	1
703	141000	cylinder bottom	2
704	140007	connecting staff	4
705	170002	connecting staff	4
706	140006	washer	2
707	140002	piston staff	2
708	170001	pneumatic cylinder canister	1
711		O-ring 31.5X3.55	2
712		washer 10	16
713		ceasing nut M10	16
714		PU pipe $\Phi 12 \times 138$	2
715		Dustproof seal 32X40	2
716		PU pipe $\Phi 8 \times 1450$	1
717		quick insert union 12-8	1
718		metal quick connector	1
719		PU pipe $\Phi 8 \times 400$	1
720		Quick insert right-angle connector 8-02	4
721		PU pipe $\Phi 6 \times 2300$	1
722		union	2
723		Hexangular flat nut M20X1.5	2
724		piston $\Phi 100$	2
725		Column hexangular bolt M12X45	2
726		PU pipe $\Phi 6 \times 2700$	1
727		PU pipe $\Phi 8 \times 180$	4
728		quick insert middle union 8-02	1
729		subminiature silencer	4
730		handle valve	2
731		quick insert middle union 6-02	4
732		PU pipe $\Phi 8 \times 300$	1
733		speed adjusting union 8-8	2
734		quick insert straight union 8-02	2
735		quick insert upright union $\Phi 8$	1
736		PU pipe $\Phi 8 \times 1100$	1
737		O rubber ring 95X2.65	4
738		oil-free piston $\Phi 32 \times \Phi 36 \times 18$	2