



IMPORTANT SAFETY INSTRUCTIONS SAVE THESE INSTRUCTIONS

Please read the entire contents of this manual prior to installation and operation. By proceeding you agree that you fully understand and comprehend the full contents of this manual. Forward this manual to all operators. Failure to operate this equipment as directed may cause injury or death.

MAN REV B 01/21/14
P/N 5900222

INSTALLATION AND OPERATION MANUAL

**6,000 POUND CAPACITY
DOUBLE STACKER
TILT PARKING LIFT**

**MODELS:
PLT-6N
PLT-6NX
PLT-6S
PLT-6SX
PLT-6W
PLT-6WX**

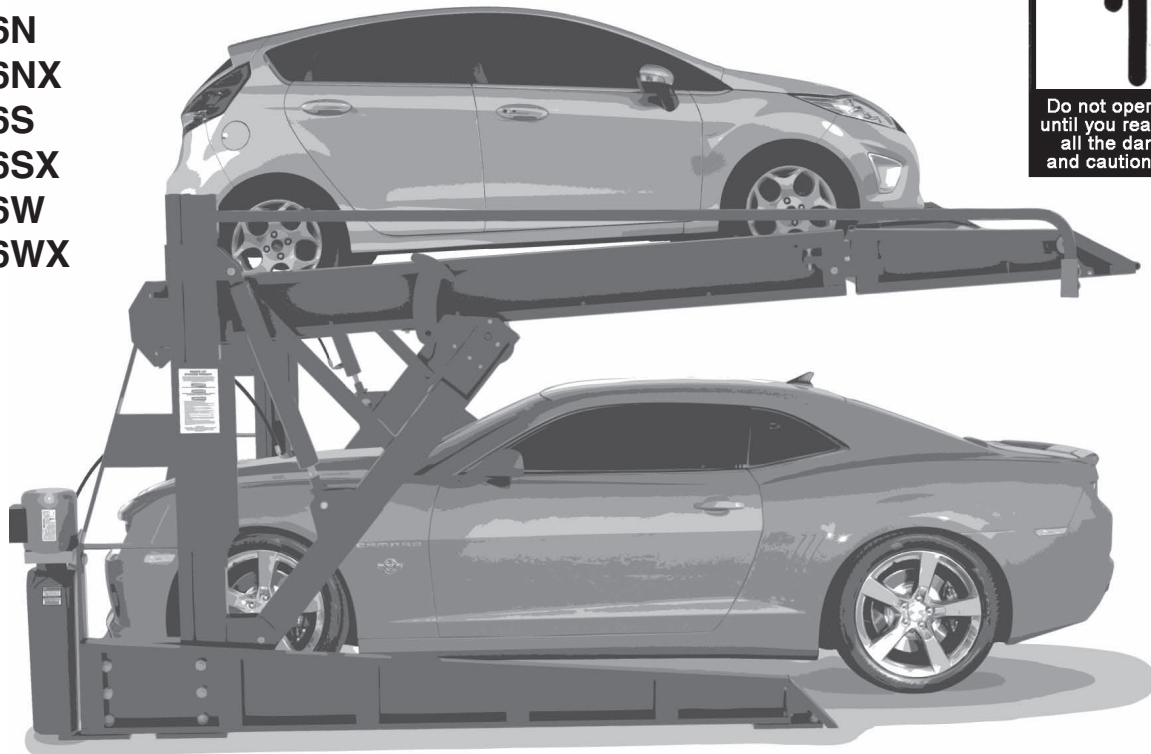

READ FIRST



Do not operate this machine until you read and understand all the dangers, warnings and cautions in this manual.

RECEIVING

When this equipment is shipped, title passes to the purchaser upon receipt from the carrier. Consequently, claims for the material damaged in shipment must be made by the purchaser against the transportation company at the time shipment is received.

BE SAFE

Your new lift was designed and built with safety in mind. However, your overall safety can be increased by proper training and thoughtful operation on the part of the operator. **DO NOT** operate or repair this equipment without reading this manual and the important safety instructions shown inside. Keep this manual near the machine at all times. Make sure that all users read and understand this manual prior to use.

1645 Lemonwood Dr.
Santa Paula, CA. 93060, USA
Toll Free 1-800-253-2363
Tel: 1-805-933-9970
Fax: 1-805-933-9160
www.bendpak.com



6,000 POUND CAPACITY DOUBLE STACKER TILT PARKING LIFTS

This instruction manual has been prepared specifically for you. Your new lift is the product of over 40 years of continuing research, testing and development; it is the most technically advanced lift on the market today.

READ THIS ENTIRE MANUAL BEFORE INSTALLATION & OPERATION BEGINS.

RECORD HERE THE LIFT AND
POWER UNIT INFORMATION WHICH IS
LOCATED ON THE SERIAL NUMBER
DATA PLATES ON THE LIFT AND
ON THE POWER UNIT

Power Unit Model # _____
Power Unit Date Of Mfg. _____
Power Unit Serial # _____

This information is required when
calling for parts or warranty issues.

MODEL NO.	_____	SERIAL NO.	_____
VOLTAGE	_____	DATE OF MFG.	_____
LIFT CAP.	_____	POWER UNIT	_____

! DANGER!
Disconnect Power
Before Servicing.

CE PCT TUV SUD SF GT

BP BendPak
PROVIDING AUTOMOTIVE SERVICE SOLUTIONS

1645 Lemonwood Drive
Santa Paula, CA 93060
www.bendpak.com

ENGINEERED BY BENDPAK USA • MADE IN CHINA

PRODUCT WARRANTY

Our comprehensive product warranty means more than a commitment to you; it's also a commitment to the value of your new BendPak lift. For full warranty details and to register your new lift contact your nearest BendPak dealer or visit <http://www.bendpak.com/support/warranty/>

NOTE:

Every effort has been taken to ensure complete and accurate instructions have been included in this manual, however, possible product updates, revisions and or changes may have occurred since this printing. BendPak Ranger reserves the right to change specifications without incurring any obligation for equipment previously or subsequently sold. Not responsible for typographical errors.

IMPORTANT NOTICE

Do not attempt to install this lift if you have never been trained on basic automotive lift installation procedures. Never attempt to lift components without proper lifting tools such as a forklift or cranes. Stay clear of any moving parts that can fall and cause injury. These instructions must be followed to insure proper installation and operation of your lift. Failure to comply with these instructions can result in serious bodily harm and void product warranty. Manufacturer will assume no liability for loss or damage of any kind, expressed or implied, resulting from improper installation or use of this product.

PLEASE READ ENTIRE MANUAL PRIOR TO INSTALLATION.

DEFINITIONS OF HAZARD LEVELS

Identify the hazard levels used in this manual with the following definitions and signal words:



DANGER !

Watch for this symbol as it means: Immediate hazards which will result in severe personal injury or death.



WARNING !

Watch for this symbol as it means: Hazards or unsafe practices which could result in severe personal injury or death.



CAUTION !

Watch for this symbol as it means: Hazards or unsafe practices which may result in minor personal injury, product or property damage.

OWNER'S RESPONSIBILITY

To maintain the lift and user safety, the responsibility of the owner is to read and follow these instructions:

- ◆ Follow all installation and operation instructions.
- ◆ Make sure installation conforms to all applicable local, state, and federal codes, rules, and regulations; such as State and Federal OSHA regulations and electrical codes.
- ◆ Carefully check the lift for correct initial function.
- ◆ Read and follow the safety instructions. Keep them readily available for machine operators.
- ◆ Make certain all operators are properly trained, know how to safely and correctly operate the unit, and are properly supervised.
- ◆ Allow unit operation only with all parts in place and operating safely.
- ◆ Carefully inspect the unit on a regular basis and perform all maintenance as required.
- ◆ Service and maintain the unit only with authorized or approved replacement parts.
- ◆ Keep all instructions permanently with the unit and all decals on the unit clean and visible.

BEFORE YOU BEGIN

NOTIFY THE CARRIER AT ONCE if any hidden loss or damage is discovered after receipt and request the carrier to make an inspection. If the carrier will not do so, prepare a signed statement to the effect that you have notified the carrier (on a specific date) and that the carrier has failed to comply with your request.

IT IS DIFFICULT TO COLLECT FOR LOSS OR DAMAGE AFTER YOU HAVE GIVEN THE CARRIER A CLEAR RECEIPT. Support claim with copies of the bill of lading, freight bill, invoice, and photographs, if available. BendPak's willingness to assist in helping you process your claim does not make BendPak responsible for collection of claims or replacement of lost or damaged materials.

CLEARANCES PLT-6 SERIES

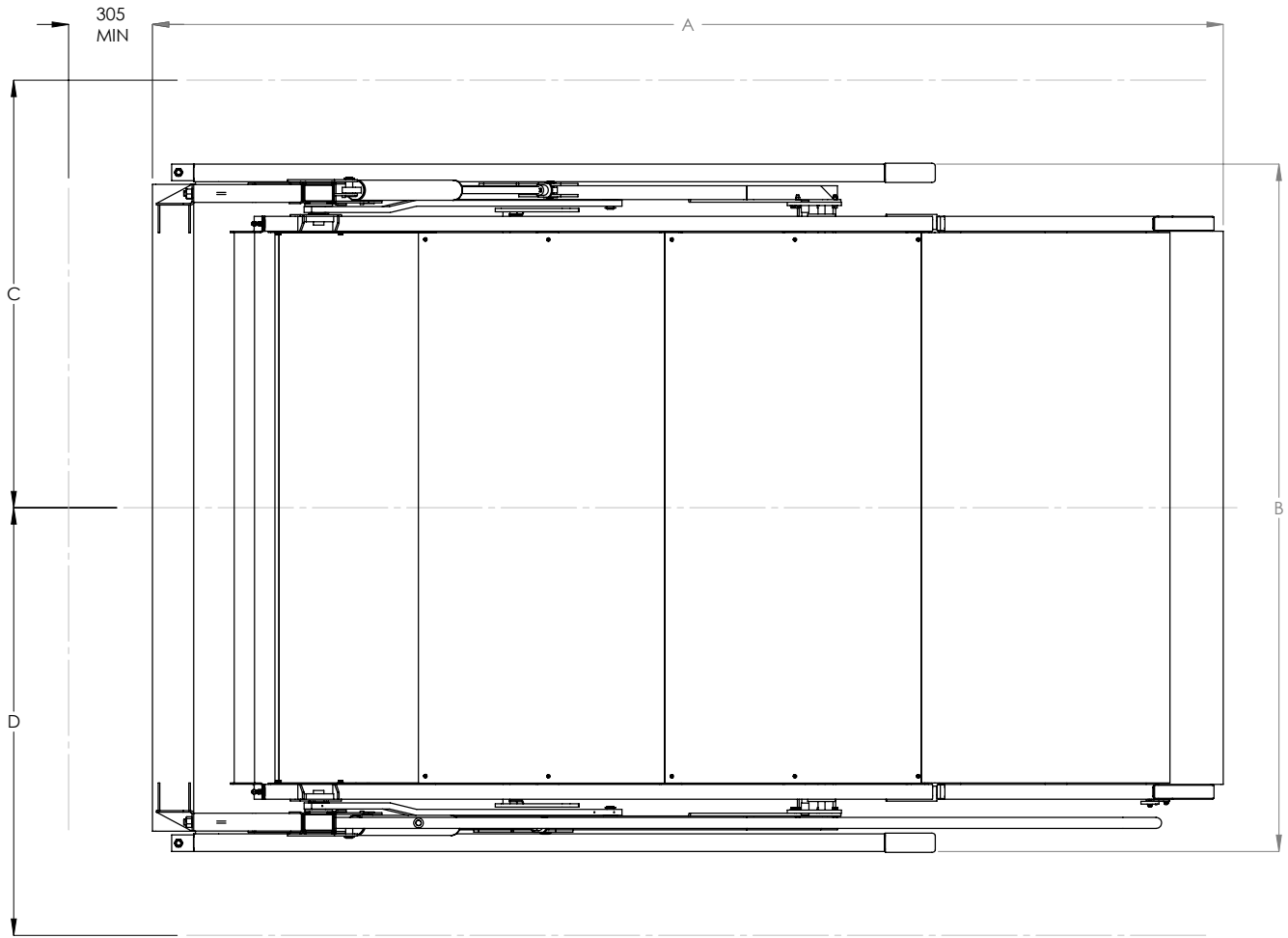

Model	PLT-6N	PLT-6NX	PLT-6S	PLT-6SX	PLT-6W	PLT-6WX
A - Overall Length	153.5" / 3899mm	153.2" / 3891mm	153.5" / 3899mm	153.2" / 3891mm	153.5" / 3899mm	153.2" / 3891mm
B - Overall Width	92.4" / 2347mm	92.4" / 2347mm	98.3" / 2497mm	98.3" / 2497mm	103.2" / 2622mm	103.2" / 2622mm
C - To Nearest Obstruction RH	58.2" / 1479mm	58.2" / 1479mm	61.2" / 1554mm	61.2" / 1554mm	63.6" / 1616mm	63.6" / 1616mm
C - To Nearest Obstruction LH	58.2" / 1479mm	58.2" / 1479mm	61.2" / 1554mm	61.2" / 1554mm	63.6" / 1616mm	63.6" / 1616mm

LIFT HEIGHT CLEARANCE NOTE: There must be a 1" MIN distance from the top of the loaded vehicle to the nearest obstruction when the lift is in a raised position.

TABLE OF CONTENTS

Contents	Page No.
Warranty / Serial Number Information	2
Definitions of Hazard Levels	3
Owner's Responsibility	3
Before You Begin	3
Clearances	4
Installer/Operator Agreement/ Protective Equipment	6
Introduction	7
Safety / Warning Instructions	7
Tools Required	8
Step 1 / Selecting Site	8
Step 2 / Floor Requirements	8
Concrete Specifications	8
Assembly View / Description of Parts / Parts Inventory	9
Floor Plan / General Specifications	10
Step 3 / Base Frame Assembly	11-12
Step 4 / Lift Arm Assembly	13
Step 5 / Lift Arm Assembly Installation	14
Step 6 / Ramp Installation Preparation	15
Step 7 / Ramp & Safety Bar Installation	15-17
Step 8 / Tire Stop Bar Installation	17
Step 9 / Drive-Up Ramp & Deck Installation	17-18
Step 10 / Cylinder Installation	19-20
Step 11 / Control Arm Installation	20
Step 12 / Lift Anchoring	20-21
Power Unit Wiring Diagram	22-23
Step 13 / Power Unit Electrical Connection	23
Step 14 / Hydraulic, Air and Electrical Line Routing	24-25
Step 15 / Lift Start-Up	25
Step 16 / Safety Installation	25-26
Step 17 / Bleeding the Cylinder	26
Post Installation Checklist	27
Step 18 / Operation	27
Safe Lift Operation	28-29
Safety Label Placement / Guidelines	30-34
Troubleshooting Guide	35-38
Lubrication Locations / Bolt Torque Specifications	39
Maintenance	40
Maintenance Records	41
Installation Form	42
Part Number Lists	43-51

**INSTALLER / OPERATOR
PLEASE READ AND FULLY
UNDERSTAND. BY PROCEEDING,
YOU AGREE TO THE FOLLOWING:**

- ◆ I have visually inspected the site where the lift is to be installed and verified the concrete to be in good condition, free of cracks or other defects. I understand that installing a lift on cracked or defective concrete could cause lift failure resulting in personal injury or death.
- ◆ I understand that a level floor is required for proper installation and level lifting.
- ◆ I understand that I am responsible if my floor is of questionable slope, and that I will be responsible for all charges related to pouring a new level concrete slab if required.
- ◆ I understand that BendPak lifts are supplied with concrete fasteners meeting the criteria of the American National Standard "Automotive Lifts - Safety Requirements for Construction, Testing, and Validation" ANSI/ALI ALCTV-2006, and that I will be responsible for all charges related to any special, regional, structural, and/or seismic anchoring requirements specified by any other agencies and/or codes such as the Uniform Building Code (UBC) and/or International Building Code (IBC).
- ◆ I will assume full responsibility for the concrete floor and condition thereof, now or later, where the above equipment model is to be installed. Failure to follow Danger, Warning, and Caution instructions may lead to serious personal injury or death to operator or bystander or damage to property.
- ◆ I understand that BendPak lifts are Designed for indoor use. Contact factory for outdoor use requirements. Failure to follow installation instructions may lead to serious personal injury, death to operator or bystander, or damage to property or lift.

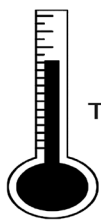

CAUTION

The safe operating temperature range for this product is 41° F. - 104 °F.



Failure to follow Danger, Warning, and Caution instructions may lead to serious personal injury, death to operator or bystander or damage to property or lift.



Please read the entire manual prior to installation. Do not operate this machine until you have read and have understood all of the Danger, Warning and Caution alerts in this manual. For additional copies or further information, contact:

BendPak Inc.

1645 Lemonwood Dr.
Santa Paula, CA. 93060
1-805-933-9970
www.bendpak.com

**INSTALLER / OPERATOR
PROTECTIVE EQUIPMENT**

Personal protective equipment helps makes installation and operation safer; however, it does not take the place of safe operating practices. **Always** wear durable work clothing during any installation and/or service activity. Shop aprons or shop coats may also be worn; however, loose-fitting clothing should be avoided.

Tight-fitting leather gloves are recommended to protect the technician's hands when handling parts. Sturdy leather steel-toe work shoes and oil resistant soles should be used by all service personnel to help prevent injury during typical installation and operation activities.

Eye protection is essential during installation and operation activities. Safety glasses with side shields, goggles, or face shields are acceptable. Everyday eyeglasses only have impact resistant lenses, they are not safety glasses. Back belts provide support during lifting activities and are also helpful in providing worker protection. Consideration should also be given to the use of hearing protection if service activity is performed in an enclosed area or if noise levels are high.



THIS SYMBOL POINTS OUT IMPORTANT SAFETY INSTRUCTIONS WHICH IF NOT FOLLOWED COULD ENDANGER THE PERSONAL SAFETY AND/OR PROPERTY OR YOURSELF AND OTHERS AND CAN CAUSE PERSONAL INJURY OR DEATH. READ AND FOLLOW ALL INSTRUCTIONS IN THIS MANUAL BEFORE ATTEMPTING TO OPERATE THIS MACHINE.

INTRODUCTION

1. Carefully remove the crating and packing materials. **CAUTION!** Be careful when cutting steel banding material as items may become loose and fall, causing personal harm or injury.

2. Check the voltage, phase, and proper amperage requirements for the motor shown on the motor plate. Electrical work should be performed only by a certified electrician.

IMPORTANT SAFETY INSTRUCTIONS

Read these safety instructions entirely. Do not attempt to install this lift if you have never been trained on basic automotive lift installation procedures. Never attempt to lift components without proper lifting tools such as forklift or cranes. Stay clear of any moving parts that may fall and cause injury. When using your garage equipment, basic safety precautions should **always** be followed, including the following:

1. Read and understand all instructions and all safety warnings before operating lift.
2. Care must be taken as burns can occur from touching hot parts.
3. Do not operate equipment with a damaged cord or if the equipment has been dropped or damaged until it has been examined by a qualified service person.
4. Do not let a cord come in contact with hot manifolds or moving fan blades.
5. If an extension cord is necessary, a cord with a current rating equal to or more than that of the equipment should be used. Cords rated for less current than the equipment may overheat. Care should be taken to arrange the cord so that it will not be tripped over or pulled.
6. **Always** unplug equipment from electrical outlet when not in use. Never use the cord to pull the plug from the outlet. Grasp plug and pull to disconnect.
7. Let equipment cool completely before putting away. Loop cord loosely around equipment when storing.
8. To reduce the risk of fire, do not operate equipment in the vicinity of open containers of flammable liquids (gasoline).
9. Adequate ventilation should be provided when working on operating internal combustion engines.
10. Keep hair, loose clothing, fingers, and all parts of body away from moving parts. Keep feet clear of lift when lowering. Avoid pinch points.
11. **DANGER!** To reduce the risk of electric shock, do not use on wet surfaces or expose to rain. The power unit used on this lift contains high voltage. Disconnect power at the receptacle or at the circuit breaker switch before performing any electrical repairs. Secure plug so that it cannot be accidentally plugged in during service, or mark circuit breaker switch so that it cannot be accidentally switched on during service.
12. Tighten all fasteners to meet recommended torque specifications found on page 33 of this manual.

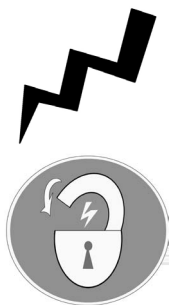

13. Use only as described in this manual. Use only manufacturer's recommended attachments.
14. **ALWAYS WEAR SAFETY GLASSES.** Everyday eye-glasses only have impact resistant lenses, they are not safety glasses.
15. Consider work environment. Keep work area clean. Cluttered work areas invite injuries. Keep areas well lit.
16. Guard against electric shock. This lift must be grounded while in use to protect operator from electric shock. Never connect the green power cord wire to a live terminal. This is for ground only.
17. Only trained operators should operate this lift. All non-trained personnel should be kept away from the work area. Never let non-trained personnel come in contact with, or operate lift.
18. **DO NOT** override self-closing lift controls.
19. Clear area if vehicle is in danger of falling.
20. **ALWAYS** make sure the safeties are engaged before attempting to work on or near a vehicle.
21. **WARNING! RISK OF EXPLOSION.** This equipment has internal arcing or sparking parts which should not be exposed to flammable vapors. This machine should not be located in a recessed area or below floor level.
22. **MAINTAIN WITH CARE.** Keep lift clean for better and safer performance. Follow manual for proper lubrication and maintenance instructions. Keep control handles and/or buttons dry, clean and free from grease and oil.
23. Check for damaged parts. Check for alignment of moving parts, breakage of parts or any condition that may affect operation of lift. Do not use lift if any component is broken or damaged.
24. **NEVER** remove safety related components from the lift. Do not use lift if safety related components are missing or damaged.
25. **STAY ALERT.** Use common sense and watch what you are doing. Remember, **SAFETY FIRST.**
26. **SAVE THESE INSTRUCTIONS.**



SAVE THESE INSTRUCTIONS

TOOLS REQUIRED

- ◆ Rotary Hammer Drill or Similar
- ◆ 3/4" Masonry Bit
- ◆ Hammer
- ◆ 4 Foot Level
- ◆ Open-End Wrench Set: SAE/Metric
- ◆ Socket And Ratchet Set: SAE/Metric
- ◆ Hex-Key / Allen Wrench Set
- ◆ Large Crescent Wrench
- ◆ Large Pipe Wrench
- ◆ Crow Bar
- ◆ Chalk Line
- ◆ Medium Flat Screwdriver
- ◆ Tape Measure: 25 Foot Minimum
- ◆ Needle Nose Pliers

IMPORTANT NOTICE

THESE INSTRUCTIONS MUST BE FOLLOWED TO INSURE PROPER INSTALLATION AND OPERATION OF YOUR LIFT. FAILURE TO COMPLY WITH THESE INSTRUCTIONS CAN RESULT IN SERIOUS BODILY HARM AND VOID PRODUCT WARRANTY. MANUFACTURER WILL ASSUME NO LIABILITY FOR LOSS OR DAMAGE OF ANY KIND, EXPRESSED OR IMPLIED, RESULTING FROM IMPROPER INSTALLATION OR USE OF THIS PRODUCT.

PLEASE READ ENTIRE MANUAL PRIOR TO INSTALLATION

STEP 1 (Selecting Site)

Before installing your new lift, check the following:

1. **LIFT LOCATION:** **Always** use architectural plans when available. Check the layout dimension against the floor plan requirements, making sure that adequate space is available.
2. **OVERHEAD OBSTRUCTIONS:** The area where the lift will be located should be free of overhead obstructions such as heaters, building supports, electrical lines, etc.
3. **DEFECTIVE FLOOR:** Visually inspect the site where the lift is to be installed and check for cracked or defective concrete.
4. Lift is designed for **INDOOR INSTALLATION ONLY**. Outdoor use permitted only if covered and dry. Always follow warnings illustrated on equipment labels.

STEP 2 (Floor Requirements)



This lift must be installed on a solid level concrete floor with no more than 3-degrees of slope. Failure to do so could cause personal injury or death.

A level floor is suggested for proper use and installation and level lifting. If a floor is of questionable slope, consider a survey of the site and/or the possibility of pouring a new level concrete slab.



- ◆ DO NOT install or use this lift on any asphalt surface or any surface other than concrete.
- ◆ DO NOT install or use this lift on expansion seams or on cracked or defective concrete.
- ◆ DO NOT install or use this lift on a second / elevated floor without first consulting building architect.
- ◆ DO NOT install or use this lift outdoors.

CONCRETE SPECIFICATIONS

LIFT MODEL	CONCRETE REQUIREMENTS
PLT-6N	4" Min. Thickness / 3,000 PSI
PLT-6NX	4" Min. Thickness / 3,000 PSI
PLT-6S	4" Min. Thickness / 3,000 PSI
PLT-6SX	4" Min. Thickness / 3,000 PSI
PLT-6W	4" Min. Thickness / 3,000 PSI
PLT-6WX	4" Min. Thickness / 3,000 PSI



DANGER!

ALL MODELS MUST BE INSTALLED ON 3000 PSI CONCRETE ONLY CONFORMING TO THE MINIMUM REQUIREMENTS SHOWN ABOVE. NEW CONCRETE MUST BE ADEQUATELY CURED FOR A MINIMUM OF 28 DAYS.

IMPORTANT NOTE

BendPak lifts are supplied with installation instructions and concrete fasteners meeting the criteria as prescribed by the American National Standard "Automotive Lifts - Safety Requirements for Construction, Testing, and Validation" ANSI/ALI ALCTV-2006. Lift buyers are responsible for any special regional structural and/or seismic anchoring requirements specified by any other agencies and/or codes such as the Uniform Building Code (UBC) and/or International Building Code (IBC).

⚠ DANGER

When removing the lift from shipping angles, pay close attention as the ramps can slide and can cause injury. Prior to removing the bolts, make sure the ramps are held securely by a fork lift or some other heavy lifting device.

PARTS INVENTORY

Be sure to take a complete inventory of major parts prior to beginning installation.

Description	Qty	Description	Qty
Left Post Weldment	1	Drive-Up Ramp Weldment	1
Right Post Weldment	1	Leveling Bar	2
Left Leg Weldment	1	Hydraulic Cylinder	2
Right Leg Weldment	1	Safety Bar	1
Control Arm	1	Roller Bar Weldment	1
Tire Stop Bar Weldment	1	Parts Box (Packing List Enclosed)	1
Hose Channel Weldment	1	Parts Bag (Packaged in Part Box)	1
Left Lift Arm Weldment	1	Power Unit	1
Right Lift Arm Weldment	1	Control Pendant	1
Deck Channel Weldment	4		
Deck Plate	2		

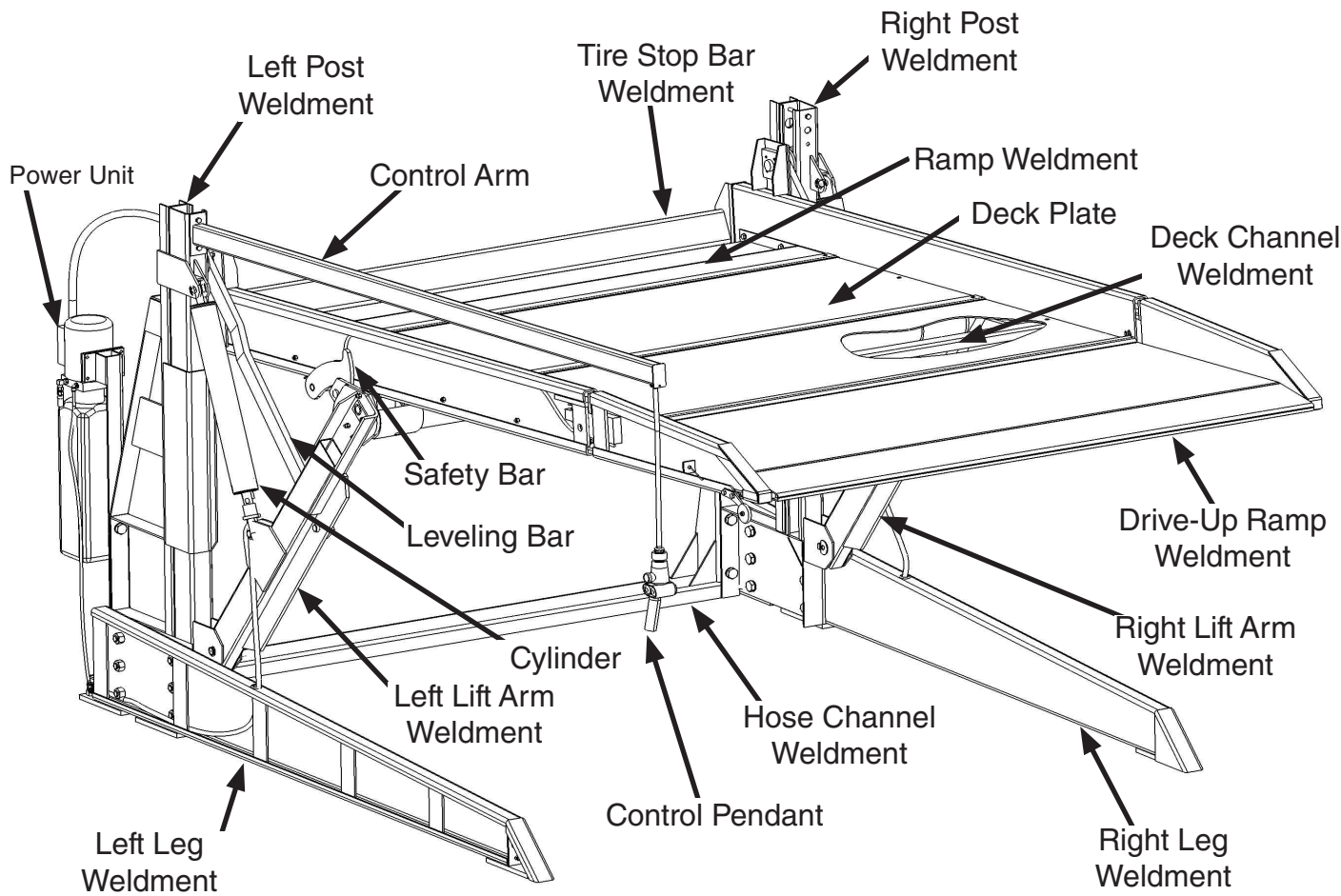

FLOOR PLAN / GENERAL SPECIFICATIONS

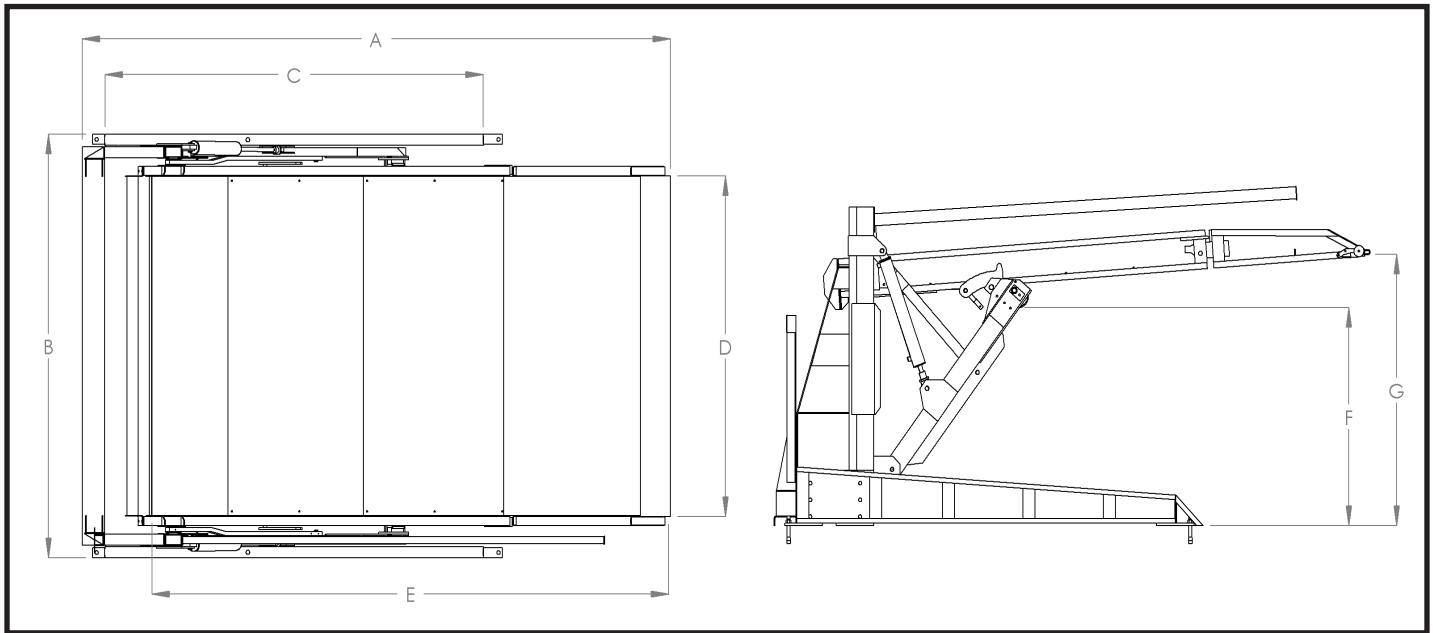

Model	PLT-6N	PLT-6NX	PLT-6S	PLT-6SX	PLT-6W	PLT-6WX
Lifting Capacity	6,000 lbs / 2,722 kg	6,000 lbs / 2,722 kg	6,000 lbs / 2,722 kg	6,000 lbs / 2,722 kg	6,000 lbs / 2,722 kg	6,000 lbs / 2,722 kg
Max capacity / front axle	3,000 lbs / 2,041 kg	3,000 lbs / 2,041 kg	3,000 lbs / 2,041 kg	3,000 lbs / 2,041 kg	3,000 lbs / 2,041 kg	3,000 lbs / 2,041 kg
Max capacity / rear axle	3,000 lbs / 2,041 kg	3,000 lbs / 2,041 kg	3,000 lbs / 2,041 kg	3,000 lbs / 2,041 kg	3,000 lbs / 2,041 kg	3,000 lbs / 2,041 kg
A - Overall Length	153.5" / 3,899 mm	153.2" / 3,891 mm	153.5" / 3,899 mm	153.2" / 3,891 mm	153.5" / 3,899 mm	153.2" / 3,891 mm
B - Overall Width	92.4" / 2,347 mm	92.4" / 2,347 mm	98.3" / 2,497 mm	98.3" / 2,497 mm	103.2" / 2,622 mm	103.2" / 2,622 mm
C - Leg Length	98.8" / 2,509 mm	98.8" / 2,509 mm	98.8" / 2,509 mm	98.8" / 2,509 mm	98.8" / 2,509 mm	98.8" / 2,509 mm
D - Width of Ramp	73.2" / 1,860 mm	73.2" / 1,860 mm	79.1" / 2,010 mm	79.1" / 2,010 mm	84.1" / 2,135 mm	84.1" / 2,135 mm
E - Length of Ramp	134.9" / 3,437 mm	135.1" / 3,432 mm	134.9" / 3,437 mm	135.1" / 3,432 mm	134.9" / 3,437 mm	135.1" / 3,432 mm
F - Max Clearance of Roller Bar	50.6" / 1,286mm	66.6" / 1,692mm	50.6" / 1,286mm	66.6" / 1,692mm	50.6" / 1,286mm	66.6" / 1,692mm
G - Max Clearance Height	62.9" / 1,599 mm	83.4" / 2,127 mm	63" / 1,600 mm	83.4" / 2,127 mm	62.9" / 1,599 mm	83.4" / 2,127 mm
Locking Positions	1	1	1	1	1	1
Lifting Time	45 Seconds	45 Seconds	45 Seconds	45 Seconds	45 Seconds	45 Seconds
Standard Motor (**)	220 VAC / 60Hz 1 Ph.	220 VAC / 60Hz 1 Ph.	220 VAC / 60Hz 1 Ph.	220 VAC / 60Hz 1 Ph.	220 VAC / 60Hz 1 Ph.	220 VAC / 60Hz 1 Ph.

** Special Voltages Available upon Request.

The design, material and specifications are subject to change without notice. Version A

STEP 3 (Base Frame Assembly)

1. Place chalk lines on the floor according to the floor plan layout. Pay attention to the clearances needed with respect to the placement of your lift location. (See Fig 3.1)

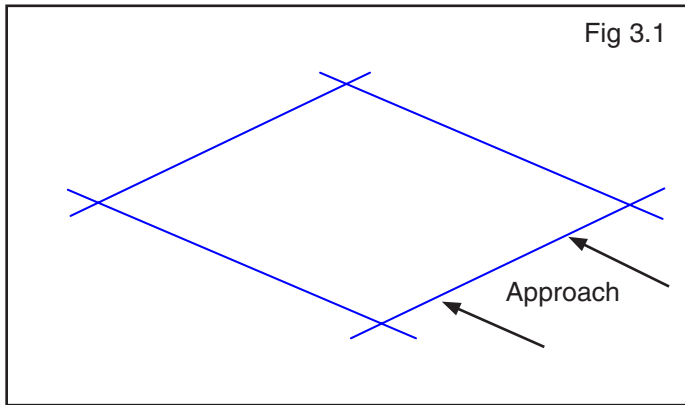

2. Make sure chalk lines are square as this layout will be your guide when bolting the lift permanently in this location.

NOTE:

IT MAY BE HELPFUL TO MEASURE YOUR CHALK LAYOUT DIAGONALLY TO CHECK FOR SQUARE.

3. Place the Hose Channel Weldment upright (with the gussets upright) on the layout so that the rearmost edge of the Hose Channel Weldment touches the chalk line. Make certain that the Hose Channel Weldment is centered on the layout. (See Fig 3.2)

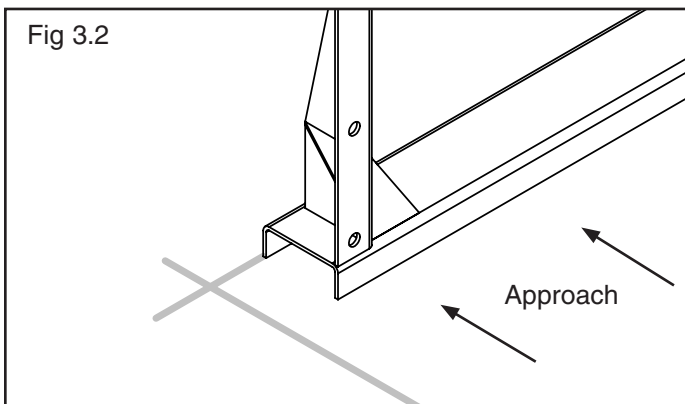

4. Locate the Left and Right Post Weldments. Place the Post Weldments within the chalk layouts, parallel with the Hose Channel Weldment, with the leg mounting plates facing upwards. When placing the post weldments inside the chalk layout, lay the bottom edge of the Left Post Weldment near the Left side chalk line and lay the bottom edge of the Right Post Weldment near the Right side chalk line. Both post straps on the two post weldments should be now facing the Hose Channel Weldment. (See Fig. 3.3)

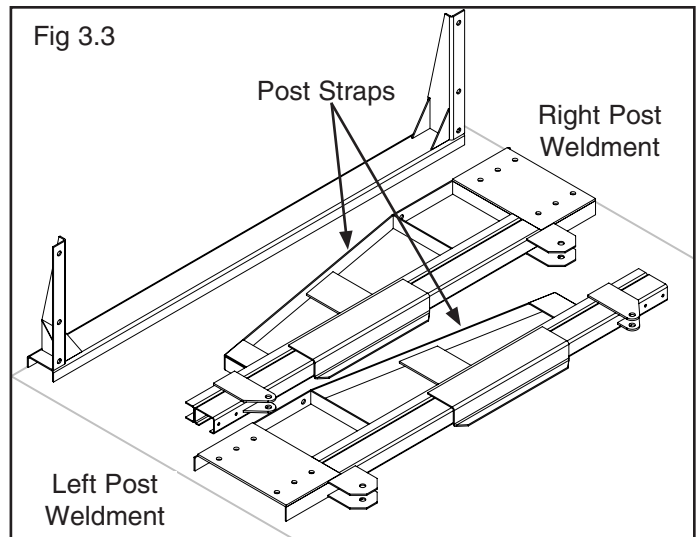

5. Locate the Left and Right Leg Weldments. The Leg Weldments may be differentiated by looking at the foot pads located on the bottom of the legs. The side of the leg weldments with the straps welded on will be on the outside of the lift. The leg that has its straps on the left side when its foot pads are set on the floor is the Left Leg Weldment. The leg that has its straps on the right side when its foot pads are set on the floor is the Right Leg Weldment. (See Fig 3.4)

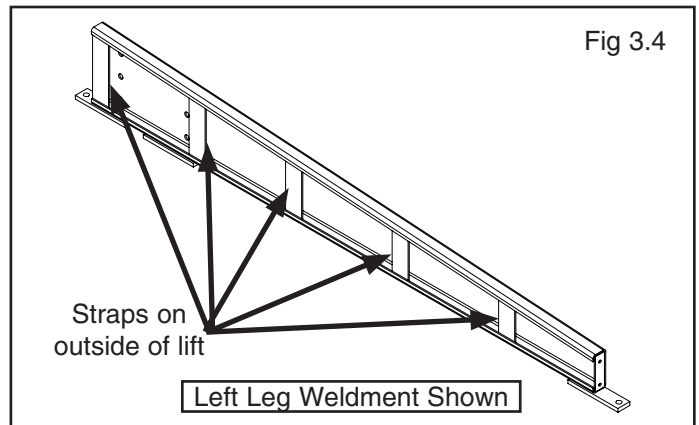

6. Place the Left Leg Weldment on top of the Left Post Weldment. Align the bolt patterns of the Left Leg Weldment and the Left Post Weldment. Place the Right Leg Weldment on top of the Right Post Weldment. Align the bolt patterns of the Right Leg Weldment and the Right Post Weldment. (See Fig. 3.5)

NOTE:

IT MAY BE HELPFUL TO PLACE WOOD BLOCKS ,OR SIMILAR SPACING BLOCKS, UNDER THE LEFT AND RIGHT LEG WELDMENTS ON THE APPROACH END OF THE LEGS TO HELP FACILITATE BOLT HOLE ALIGNMENT. USE CARE TO NOT SCRATCH THE FINISH OF THE LIFT.

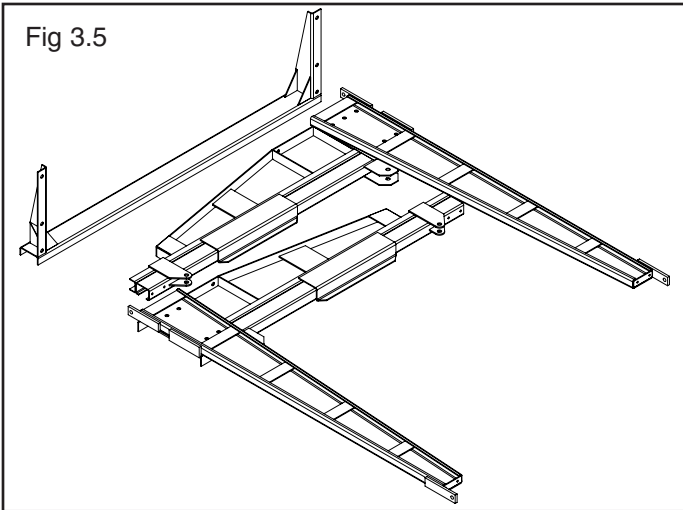

7. Using the provided M20 hardware, install six nuts, six bolts and six washers on both sides. (See Fig 3.6)

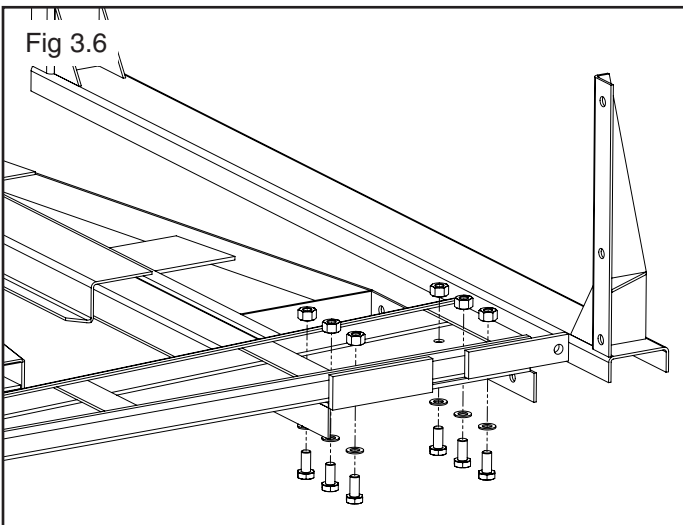

8. Raise the Left Post-Leg Assembly upright. (See Fig 3.7)

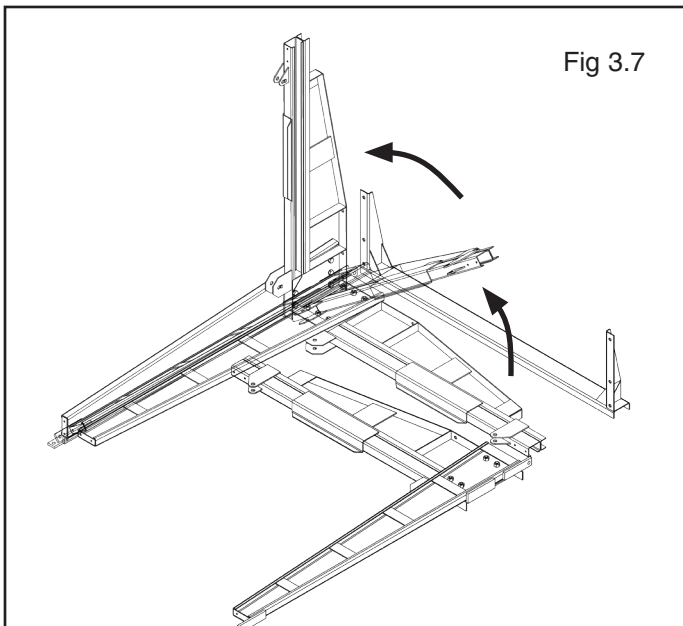

9. Locate the Power Unit Post Weldment.

! WARNING

WARNING!
 THIS STEP REQUIRES LIFTING OF VERY HEAVY COMPONENTS. BE SURE TO USE THE CORRECT LIFTING TOOLS SUCH AS A FORKLIFT OR CRANE TO POSITION COMPONENTS. PAY ATTENTION TO COMPONENT POSITION ONCE COMPONENT IS LIFTED. ONCE LIFTED, COMPONENT IS A FALLING HAZARD. FAILURE TO USE THE CORRECT LIFTING TOOLS OR TO PAY ATTENTION DURING LIFTING MAY RESULT IN PERSONAL INJURY OR DEATH. A MINIMUM OF A TWO PERSON INSTALLATION TEAM IS RECOMMENDED FOR SAFE LIFTING PRACTICES.

10. Align the mounting holes of the Hose Channel Weldment, the Left Post-Leg Assembly and the Power Unit Post Weldment. Using the provided M20 hardware, install three nuts, three bolts, and three washers to mate the assembly together. (See Fig 3.8)

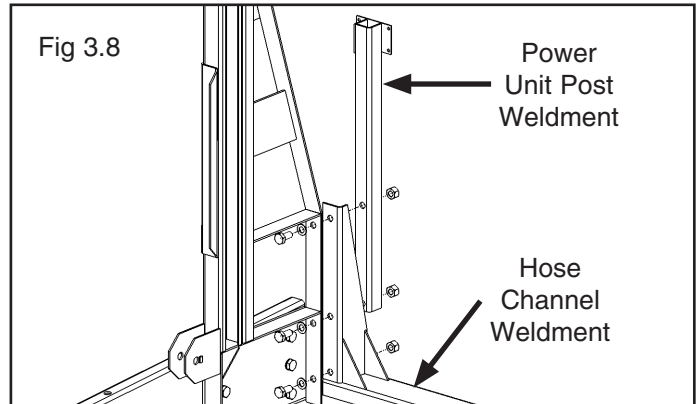

11. Repeat Items 8 and 9 of Step 3 for the mating of the Right Post-Leg Assembly and the Hose Channel Weldment.

12. The Base Frame Assembly is now complete. Do not anchor the Base Frame at this time. (See Fig 3.9)

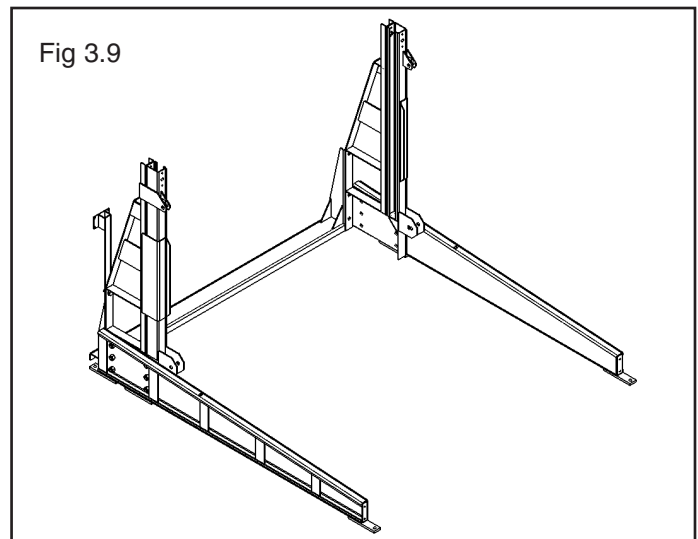

STEP 4 (Lift Arm Assembly)

1. Locate the Left and Right Lift Arm Weldments. The Lift Arms may be differentiated by the gusset orientation. The Lift Arm Gussets are **always** located on the outboard sides of the lift. (See Fig 4.1)

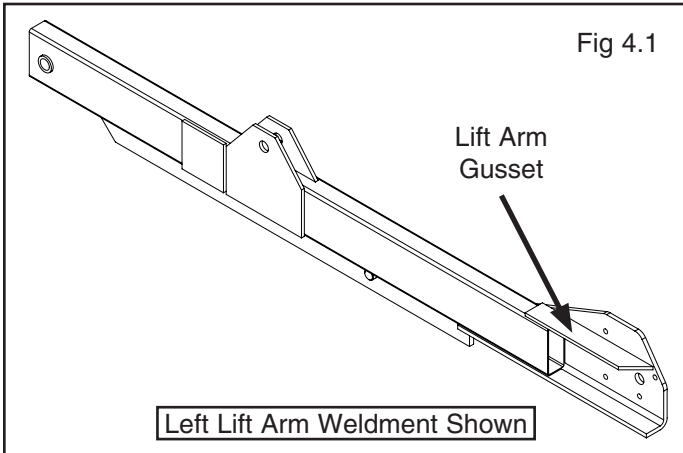

2. Locate the Roller Bar Weldment. The chamfered feature of the ear plates will be facing towards the approach end of the lift. (See Fig. 4.2)

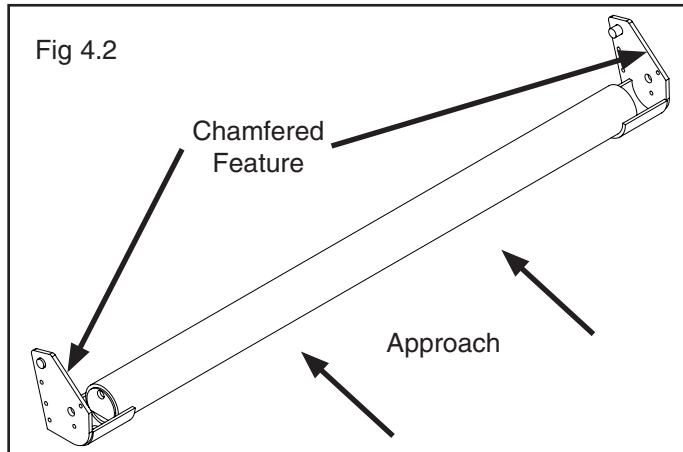

3. Assemble the Left and Right Lift Arm Weldments to the Roller Bar Weldment. Align the mounting holes and install eight sets of M10 nuts, bolts, and washers (four per arm) for both Left and Right sides. The two sets of bolts are left over for the Lift Arm Roller Pin installations. (See Fig 4.3 - 4.4)

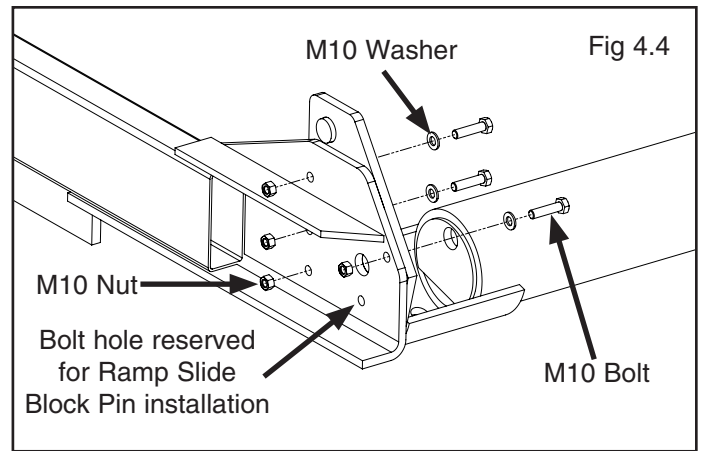
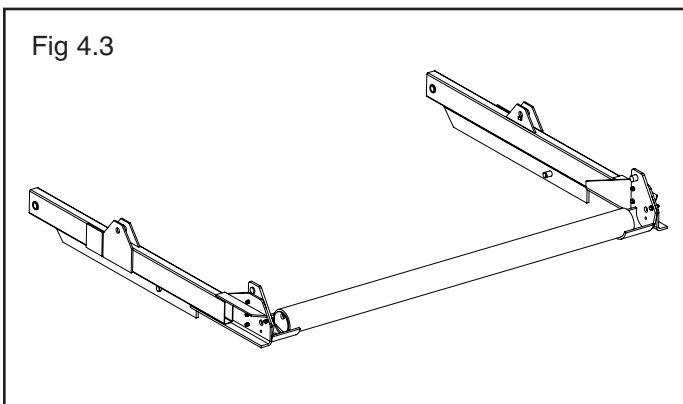

4. Locate the Lift Arm Slide Blocks and Spacers. The Slide Blocks are to be installed with the flanges oriented away from the inside of the lift. Align the Slide Block holes with the pin thru holes in the Lift Arm Assembly. Insert the Slide Block Pins through the aligned holes and Spacers and fasten the Pins to the assembly with the remaining sets of M10 hardware. (See Fig 4.5)

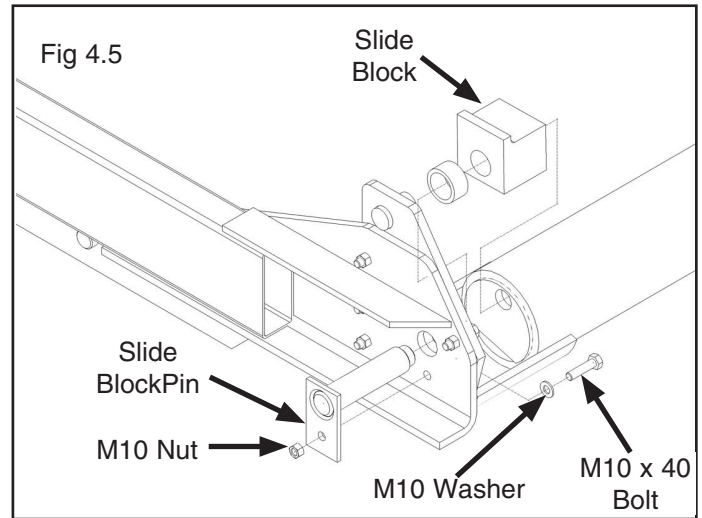

5. The Lift Arm is now assembled. (See Fig 4.6)

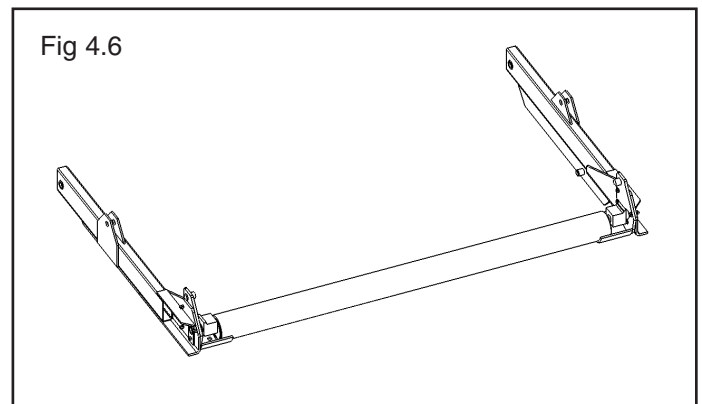

STEP 5 (Lift Arm Assembly Installation)



WARNING!

THIS STEP REQUIRES LIFTING OF A VERY HEAVY COMPONENT. BE SURE TO USE THE CORRECT LIFTING TOOLS SUCH AS A FORKLIFT OR CRANE TO POSITION COMPONENTS. PAY ATTENTION TO COMPONENT POSITION ONCE COMPONENT IS LIFTED. ONCE LIFTED, COMPONENT IS A FALLING HAZARD. FAILURE TO USE THE CORRECT LIFTING TOOLS OR TO PAY ATTENTION DURING LIFTING MAY RESULT IN PERSONAL INJURY OR DEATH. A MINIMUM OF A TWO PERSON INSTALLATION TEAM IS RECOMMENDED FOR SAFE LIFTING PRACTICES.

1. The Lift Arm Assembly will be assembled with two pivot pins and two retaining clips. Lift the Lift Arm Assembly, as completed in Step 4, into position so that both Lift Arm pivots are in between their respective arm clevises and align the holes. (See Fig. 5.1)

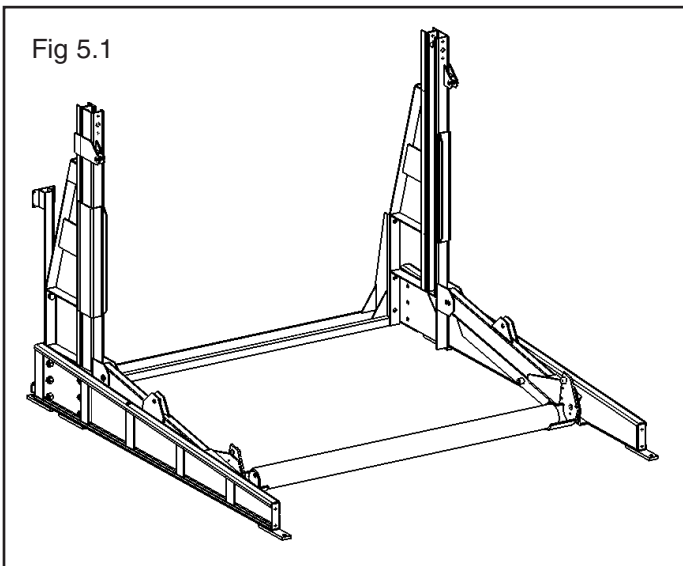

2. Once the bores are aligned with their respective thru holes, insert the Lift Arm Pivot Pin. The pins' shoulders must be located on the "in" side of the lift. The notch in the pin's shoulder should be fitted to the welded on pin stop. (See Fig. 5.2 - 5.3)

3. Once pins have been inserted, install the provided retaining clips to secure the pins in place. (See Fig. 5.4)

4. Using a Needle Point Lubrication Tool, inject lubricant into the hole in both Lift Arm Pivot Pins to lubricate the assembly. (See Fig. 5.5)

5. The Lift Arm Assembly installation is now complete.

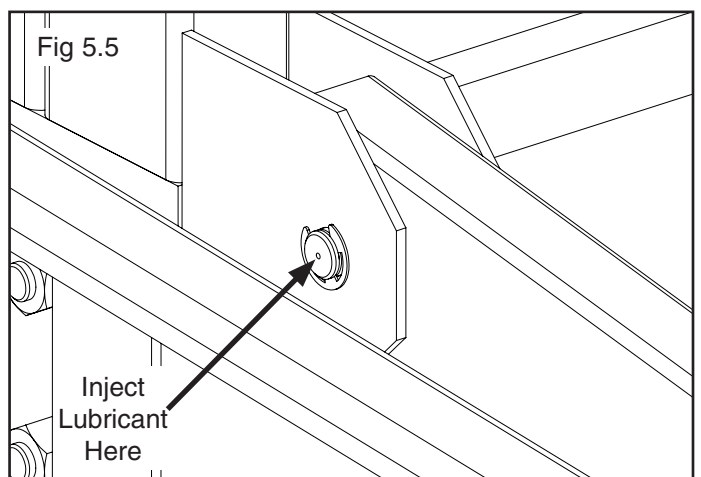
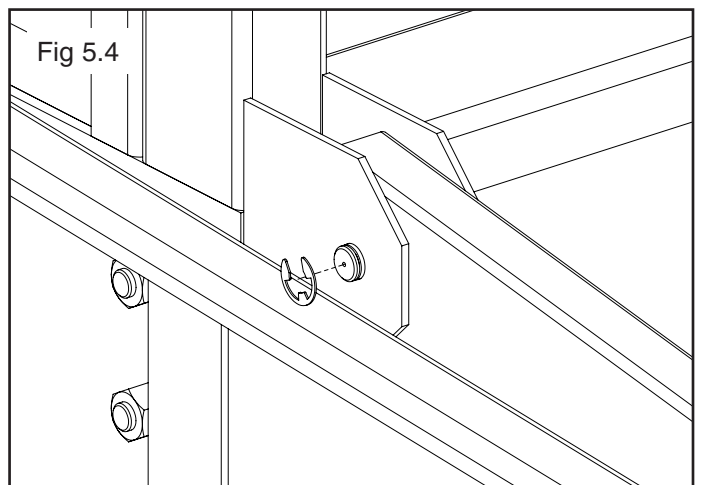
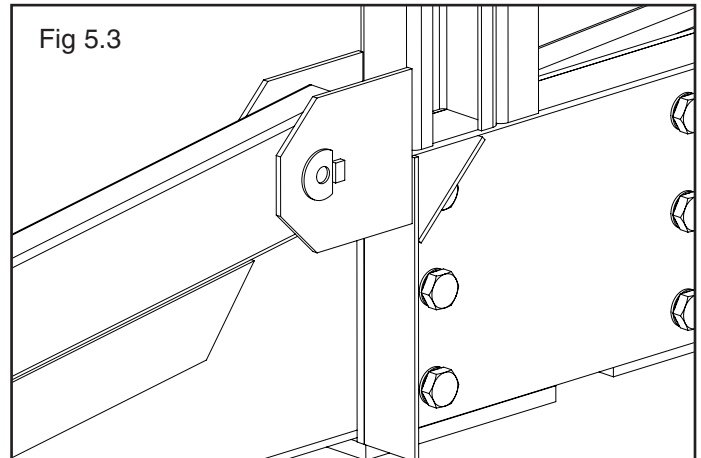
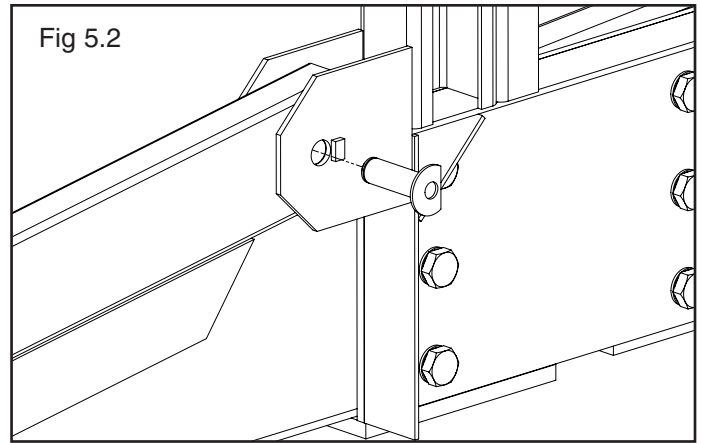

STEP 6 (Ramp Installation Preparation)

1. Locate the Post Rollers and slide one Post Roller down into each post. (See Fig 6.1)

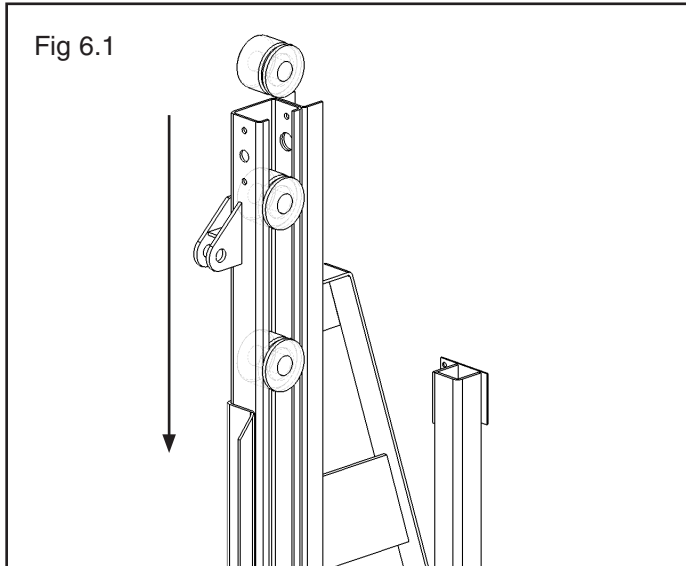

2. Locate the two Leveling Bars and install them on to the Lift Arms. Find the Leveling Bar end with the two thru holes. Orient the Leveling Bar so that the bend is facing inward, place an Arm Spacer Bearing onto the pin, and slip the outermost hole over the Lift Arm Leveling Pin. (See Fig 6.2-6.3)

NOTE:

GREATER UNDERRAMP CLEARANCE MAY BE POSSIBLE WHEN THE LEVELING BAR IS INSTALLED SO THAT THE LIFT ARM LEVELING PIN IS IN THE INNERMOST HOLE POSITION. THIS WILL INCREASE THE RAMP LIFTING ANGLE.



WARNING!

MAKE CERTAIN THE TWO LEVELING BARS ARE IN THE SAME PIN POSITION PRIOR TO OPERATION OF LIFT. FAILURE TO ENSURE BOTH BARS ARE IN THE SAME PIN POSITION WILL CAUSE LIFT MALFUNCTION AND VOID WARRANTY.

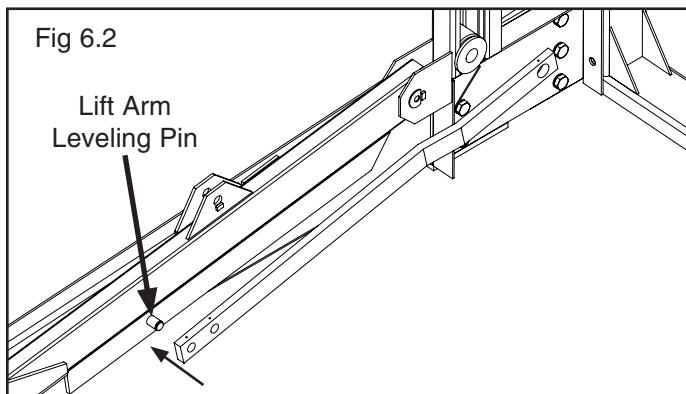

3. Secure the Leveling Bars to the Lift Arm Leveling Pins with a E-Ring retaining ring. (See Fig 6.3)

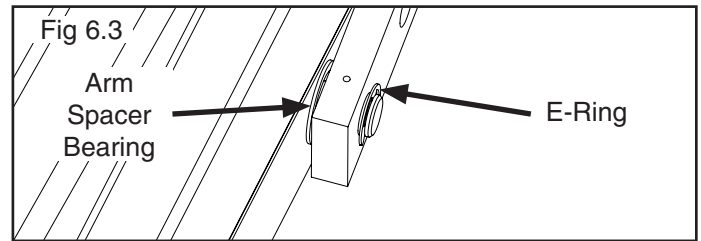

STEP 7 (Ramp & Safety Bar Installation)

1. Locate the two Ramp Channel Weldments. The Left and Right side may be differentiated by the Post Roller Plate at the rear and the open section of channel of each Ramp Side Weldment facing the outside of the lift. (See Fig 7.1)

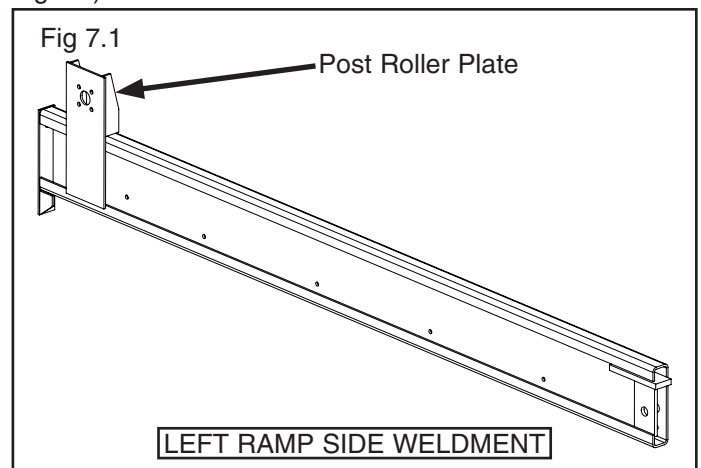

2. Insert a Post Roller Pin through each of the two Roller Plates on the two Ramp Channel Weldments. (See Fig 7.2)

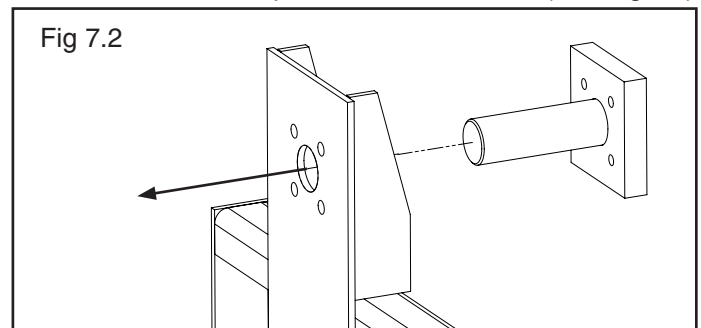

3. Install four M10 x 25 bolts to secure the Post Roller Pins on to both Ramp Channel Weldments. (See Fig 7.3)

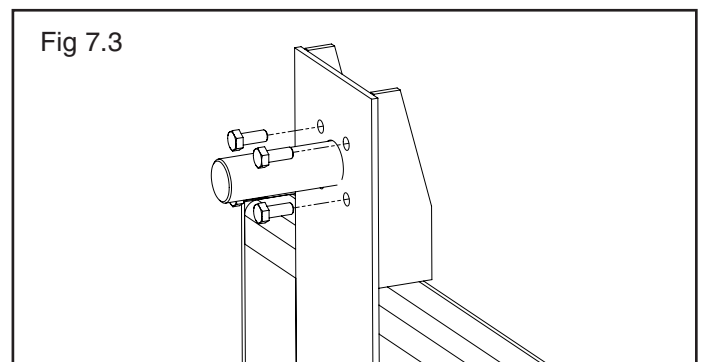

4. Slip the Arm Spacer and Arm Spacer Bearing on to each Post Roller Pin. (See Fig 7.4)

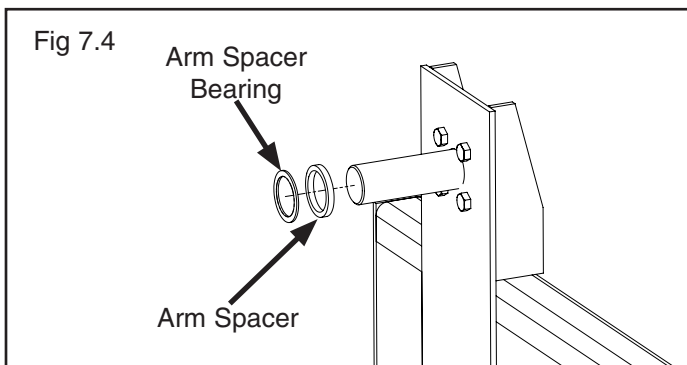

5. Take both Ramp Channel Weldments and align the Post Roller Pins, Leveling Arms, and Post Rollers in preparation for assembly.

6. Place Arm Spacer Bearings in between the Post Rollers and the Leveling Arms and insert the Post Roller Pins through the Leveling Arm, Arm Spacer Bearing and Post Roller on each side. (See Fig 7.5)

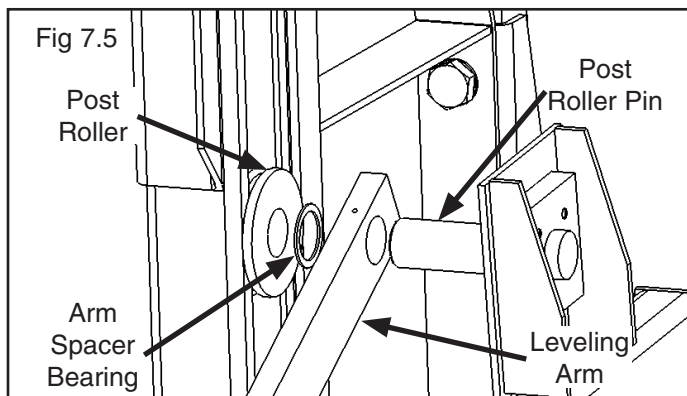

7. The Ramp Channel Weldments are now installed. Be careful to not disturb them as they are still not secure. (See Fig 7.6)



WARNING!
USE CAUTION WHEN WORKING AROUND THE RAMP CHANNEL WELDMENTS AT THIS TIME AS THE RAMP CHANNEL WELDMENTS ARE NOT SECURED AND ARE AT RISK OF FALLING. PAY ATTENTION TO THE RAMP CHANNEL WELDMENTS. FAILURE TO PAY ATTENTION MAY LEAD TO PERSONAL INJURY.

NOTE:
IT MAY BE HELPFUL TO BRACE THE RAMP CHANNEL WELDMENTS IN THEIR CURRENT POSITION BY TYING A ROPE AROUND EACH POST AND RAMP CHANNEL WELDMENT TO PREVENT THEM FROM FALLING.

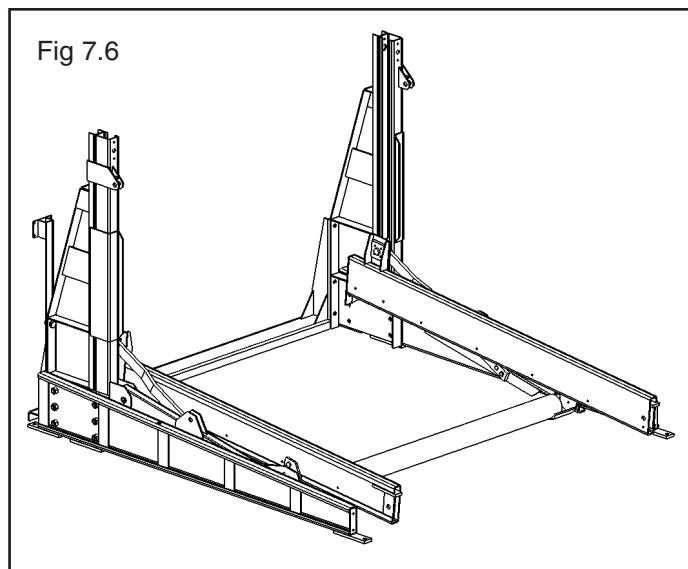

WARNING!
THIS STEP REQUIRES LIFTING OF VERY HEAVY COMPONENTS. BE SURE TO USE THE CORRECT LIFTING TOOLS SUCH AS A FORKLIFT OR CRANE TO POSITION COMPONENTS. PAY ATTENTION TO COMPONENT POSITION ONCE COMPONENT IS LIFTED. ONCE LIFTED, COMPONENT IS A FALLING HAZARD. FAILURE TO USE THE CORRECT LIFTING TOOLS OR TO PAY ATTENTION DURING LIFTING MAY RESULT IN PERSONAL INJURY OR DEATH. A MINIMUM OF A TWO PERSON INSTALLATION TEAM IS RECOMMENDED FOR SAFE LIFTING PRACTICES.

8. Lift the Ramp Weldment into the center of the lift in between the two Ramp Channel Weldments. Orient the Ramp Weldment so that the lower section of the ramp faces away from the approach side and align the mounting holes. (See Fig 7.7)

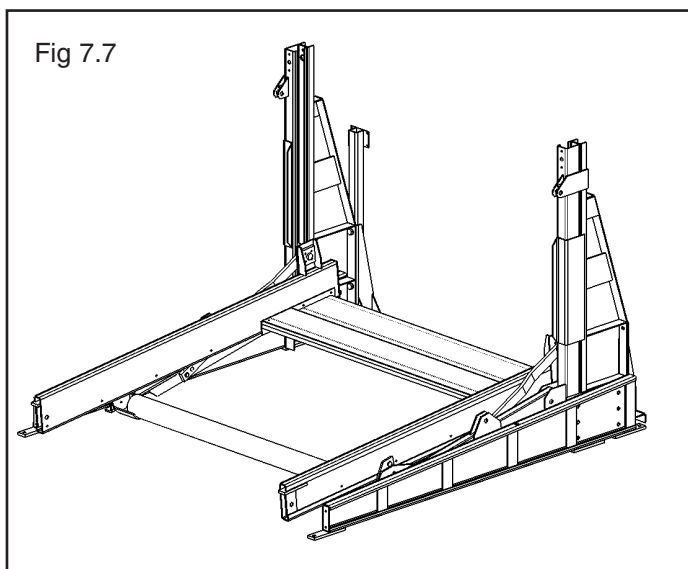

- Install six sets of M10 bolts, washers, and nuts to fasten the Ramp Weldment to the Ramp Side Weldments. (See Fig 7.8)

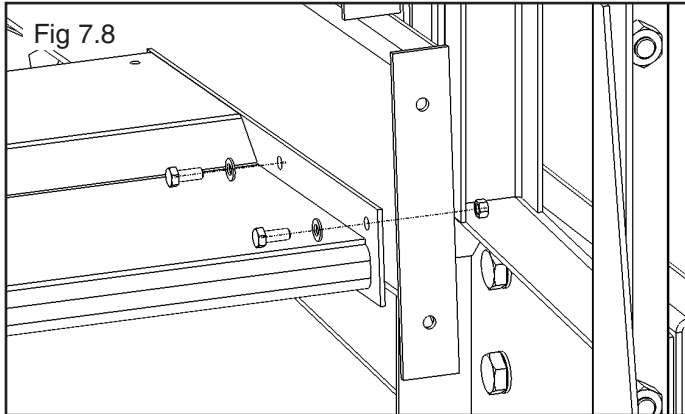

STEP 8 (Tire Stop Bar Installation)

- Locate the Tire Stop Bar Weldments. Orient the Tire Stop Bar so that the bar angles away from the lift and align the mounting holes. (See Fig 8.1)

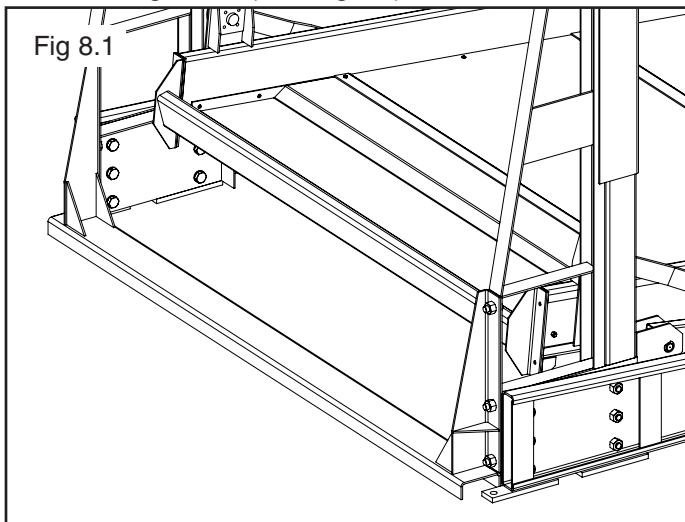

- Use the supplied M10 bolts, washers, and hex nuts to securely fasten the Tire Stop Bar to the Ramp Assembly. (See Fig 8.2)

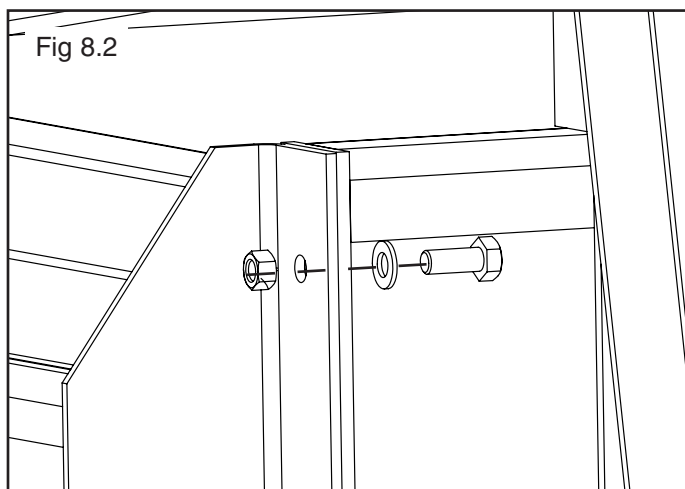

STEP 9 (Drive-Up Ramp & Deck Installation)



WARNING!

THIS STEP REQUIRES LIFTING OF A VERY HEAVY COMPONENT. BE SURE TO USE THE CORRECT LIFTING TOOLS SUCH AS A FORKLIFT OR CRANE TO POSITION COMPONENT. PAY ATTENTION TO COMPONENT POSITION ONCE COMPONENT IS LIFTED. ONCE LIFTED, COMPONENT IS A FALLING HAZARD. FAILURE TO USE THE CORRECT LIFTING TOOLS OR TO PAY ATTENTION DURING LIFTING MAY RESULT IN PERSONAL INJURY OR DEATH. A MINIMUM OF A TWO PERSON INSTALLATION TEAM IS RECOMMENDED FOR SAFE LIFTING PRACTICES.

- Locate the Drive-Up Ramp Weldment. Orient the Drive-Up Ramp so that the bars protruding from the Drive-Up Ramp point towards the Ramp Assembly. (See Fig 9.1)

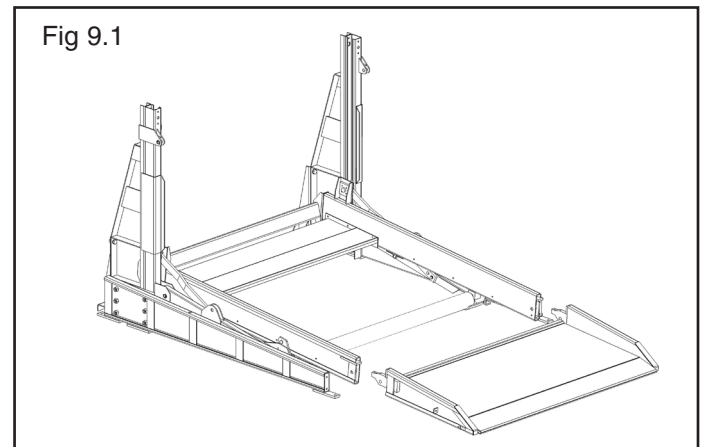

- Install a M12 x 70mm adjustment screw and jam nut to each side of the Drive-Up Ramp. (See Fig 9.2)

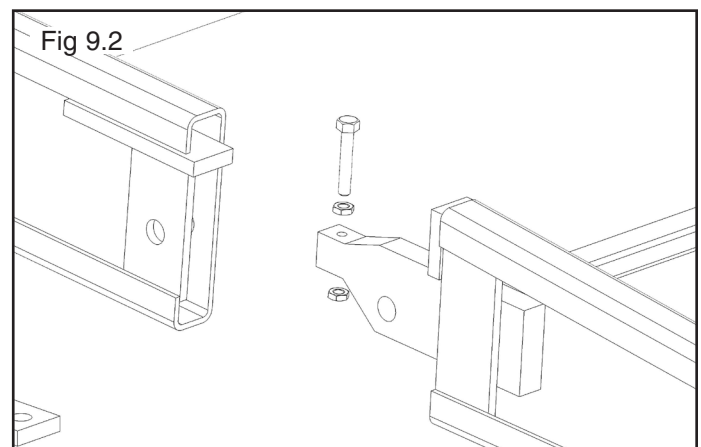

- Lift the Drive-Up Ramp Weldment and align the thru holes of the Drive-Up Ramp bars to the Ramp Assembly. The bars should slide in between the strap and the ramp channel on both Ramp Channels. (See Fig 9.3)

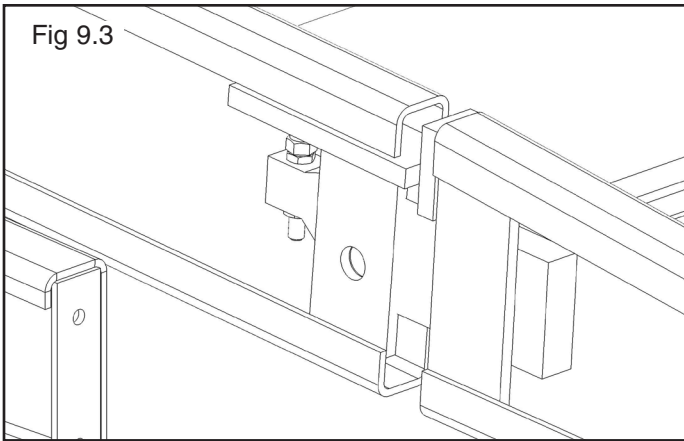

Fig 9.3

4. Place a Drive-Up Ramp Pin through each of the aligned holes to fasten the Drive-Up Ramp to the Ramp Assembly. (See Fig 9.4)

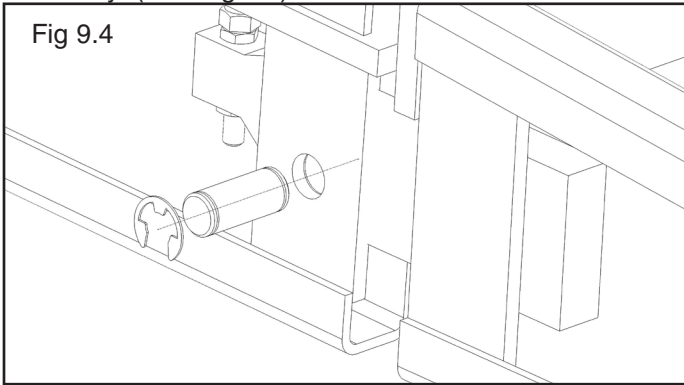

Fig 9.4

5. Secure the Drive-Up Ramp Pins by installing E-Ring retaining rings in the snap ring grooves in the pins. (See Fig 9.5)

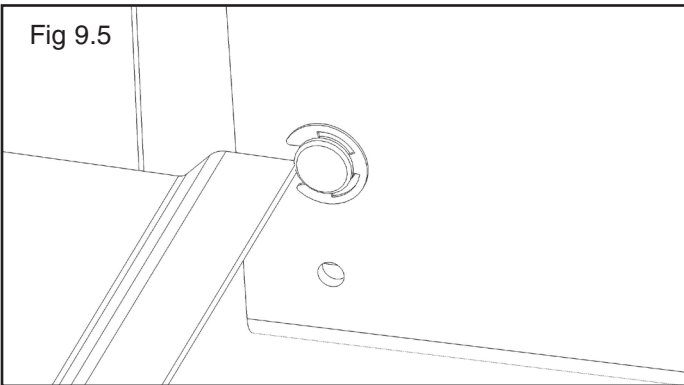

Fig 9.5

6. Install the four Deck Channel Weldments next. Orient the Deck Channel Weldments so that the “open” side of the channel face towards the ground. Use M10 bolts, washers, and nuts to fasten the Deck Channel Weldments to the Ramp Side Weldments. (See Fig 9.6)

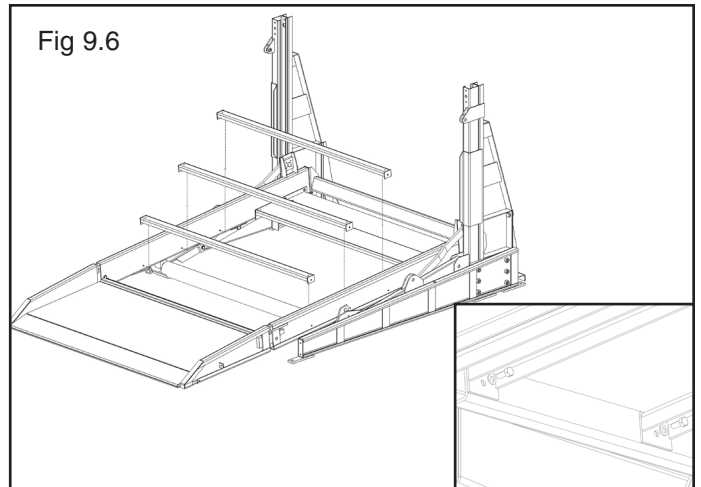

Fig 9.6

7. Place the Deck Plates on top of the Deck Channel Weldments. The “lip” of the Front Deck Plate will overlap the Center Deck Plate. The Center Deck Plate “lip” will overlap the Ramp Weldment. Align the mounting holes and use the M6 Pan Head Phillips Screws, M6 spring lock washers, and M6 nuts to mount the Deck Plates to the Deck Channels. (See Fig 9.7-9.8)

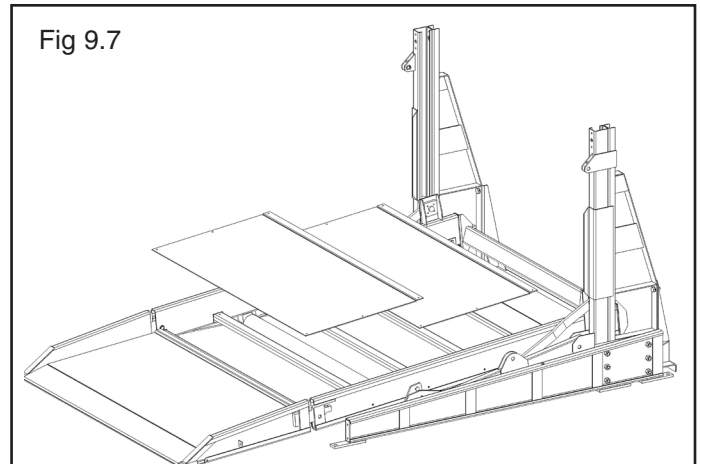

Fig 9.7

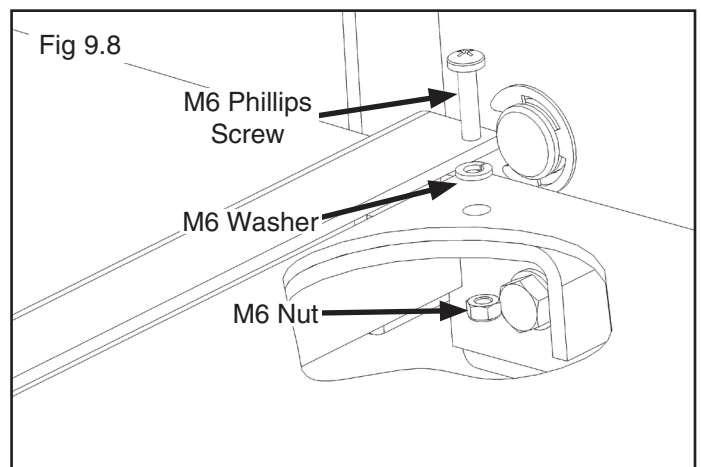

Fig 9.8

M6 Phillips
Screw

M6 Washer

M6 Nut

STEP 10 (Cylinder Installation)

1. To install a cylinder, align the thru holes of the Cylinder Clevis of the Cylinder Tube end and the Cylinder Clevis Brackets. Install Cylinder Clevis Pin through the thru holes and secure pin with 2 E-Rings. Make sure the Cylinder Hydraulic Ports face toward the post. (See Fig 10.1)

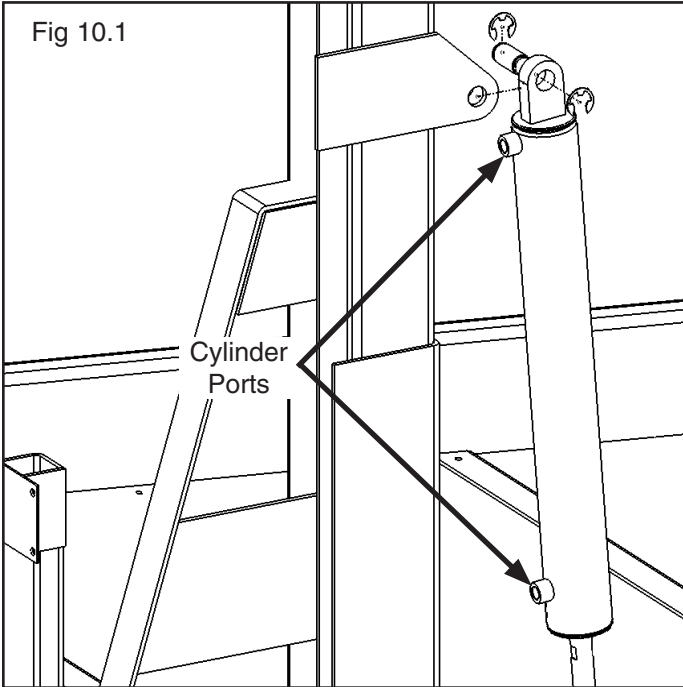

2. Install the Rod End Connector to the Cylinder Rod if it has not been installed already. Thread Rod End Connector on to Cylinder Rod until Connector threads are fully engaged. (See Fig 10.2)

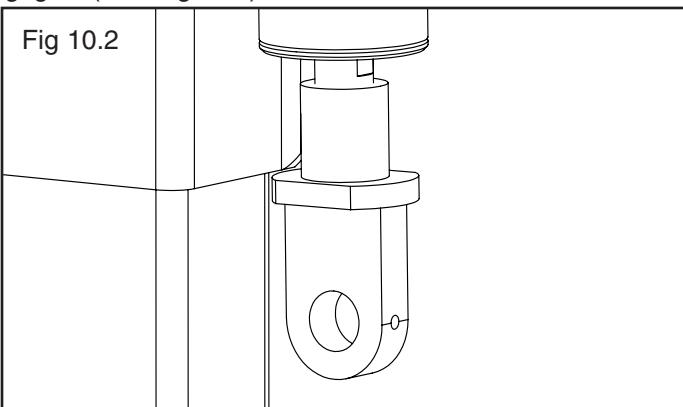

3. In order to connect the Rod End Connector to the lift it is necessary to first extend the Hydraulic Cylinder. Remove both Cylinder port plugs then use an air gun or come-along to extend the Cylinder. Once fully extended, align the thru holes of the Rod End Connector and the Clevis Plates of the Lift Arm. Insert the Lift Arm Clevis Pin through the holes and secure it with 2 E-Rings. Install the Rubber Grommet into to hole in the Leg Weldment at this time, if it has not been installed already. (See Fig 10.3 - 10.4)

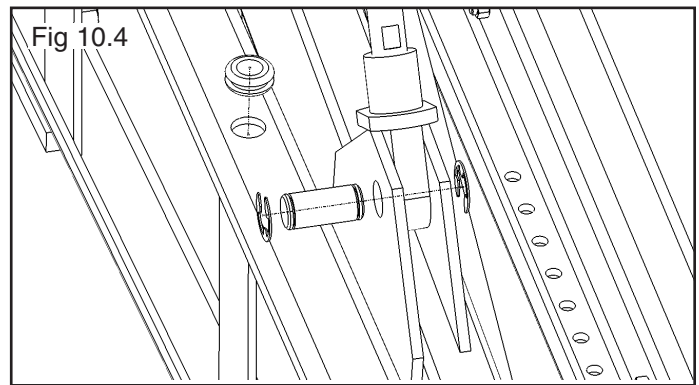

4. Install the supplied 90° -04 JIC to -06 NPT fitting to the lower port and the 90° Push-to-connect Air Fitting to the upper port. Apply Teflon tape to the NPT threads on the fitting prior to installation. (See Fig 10.5)

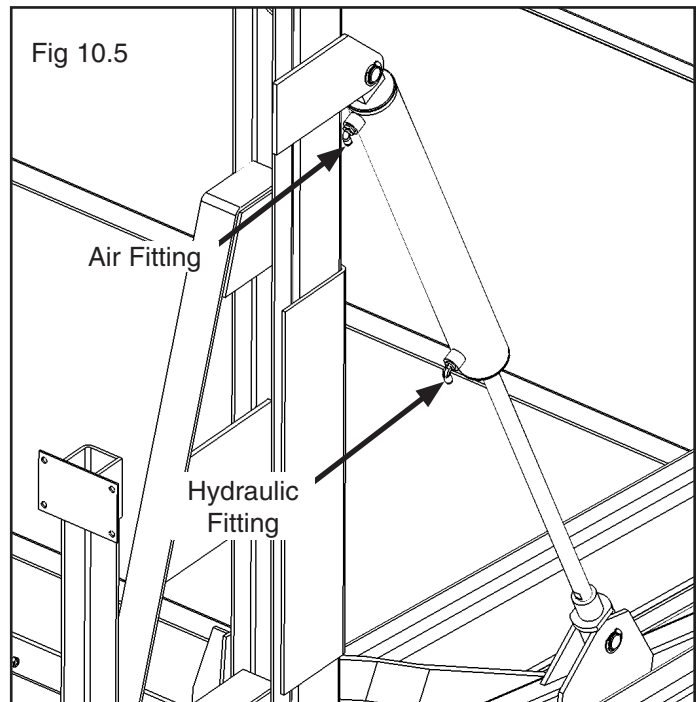

- Repeat Items 1 - 4 to install the second cylinder.
- Cylinder installation is now complete. (See Fig 10.6)

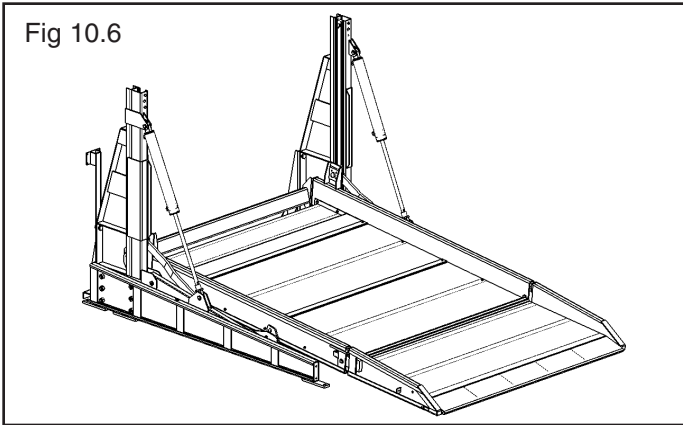

STEP 11 (Control Arm Installation)

NOTE:

THE CONTROL ARM MAY BE INSTALLED ON EITHER THE RIGHT OR LEFT HAND SIDE OF THE LIFT. FOR CLARITY THIS MANUAL WILL ONLY SHOW THE CONTROL ARM INSTALLED ON THE LEFT SIDE OF THE LIFT.

- Locate the Control Arm Weldment and align the mounting holes with the mounting holes on the Post Weldment. Make sure the Control Arm is oriented so that the Arm Tube is angled upwards. NOTE: It may be helpful to route the Control Pendant cable at this time. (See Fig 11.1)

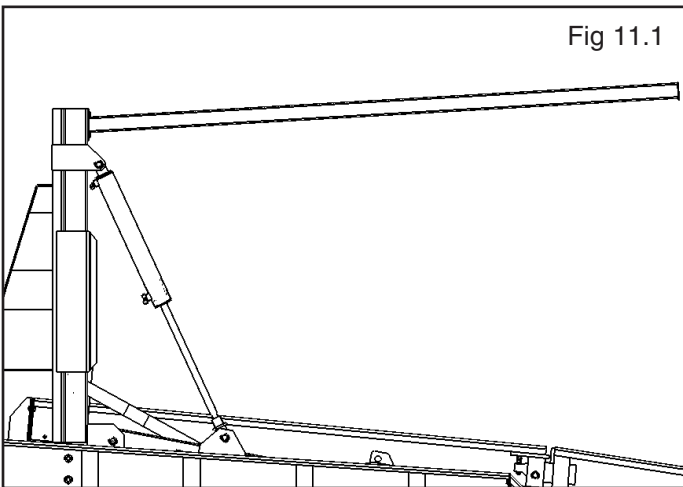

- Bolt the Control Arm Weldment and the Post Weldment together using the supplied M10 bolts, nuts, and washers. NOTE: Make sure to insert the 140mm long bolt through the top hole in BOTH SIDES of the post and the 25mm long bolt through the bottom hole. (See Fig 11.2)

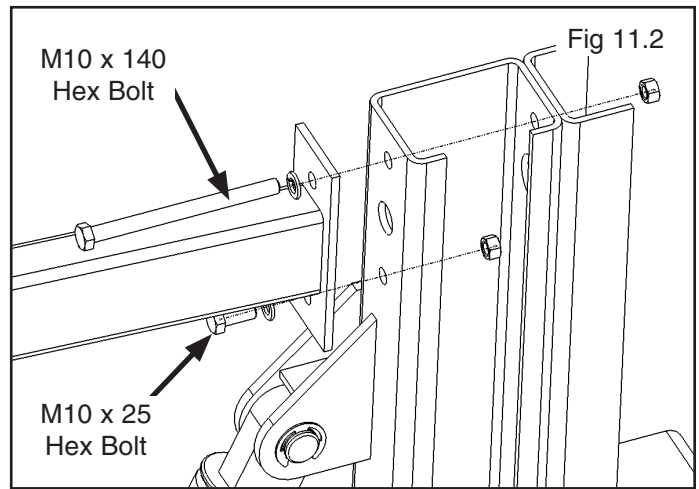

STEP 12 (Lift Anchoring)

IMPORTANT NOTE:

BendPak lifts are supplied with installation instructions and concrete fasteners meeting the criteria as prescribed by the American National Standard "Automotive Lifts - Safety Requirements for Construction, Testing, and Validation" ANSI/ALI ALCTV-2006. Lift buyers are responsible for any special regional structural and/or seismic anchoring requirements specified by any other agencies and/or codes such as the Uniform Building Code (UBC) and/or International Building Code (IBC).

- Before proceeding, make certain the lift is positioned with proper clearances around and overhead. (See clearances section on page 4)
- Locate the 4 anchor points. (See Fig. 12.1)

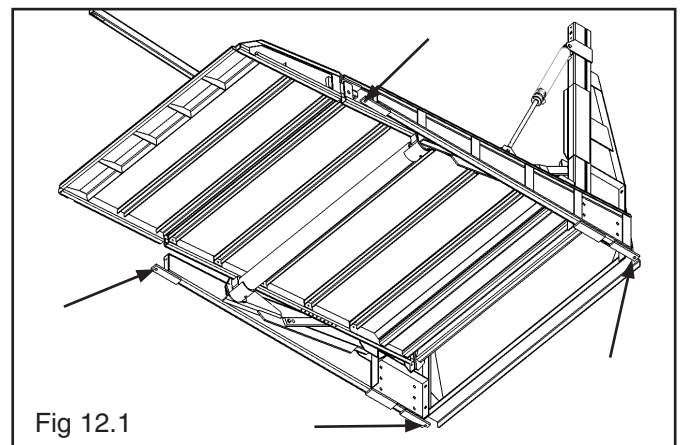

- Using the Foot Pad as a guide, drill each anchor hole in the concrete (approximately 4" deep) using a rotary hammer drill and 3/4" concrete drill-bit. To ensure full holding power, do not ream the hole or allow the drill to wobble. (See Fig. 12.2)

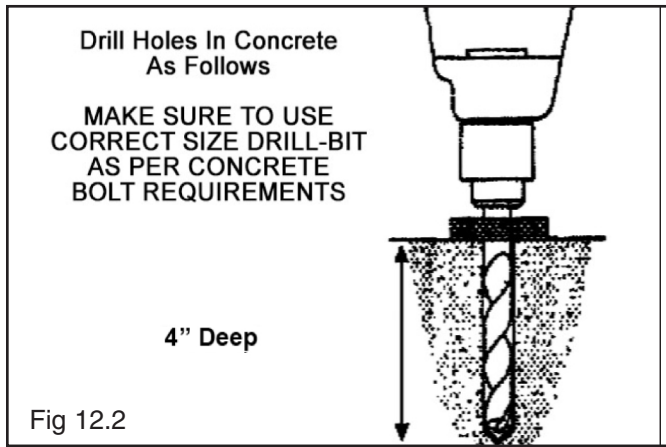

4. After drilling the anchor holes, remove the dust thoroughly from each hole using compressed air and/or wire brush. (See Fig 12.3)

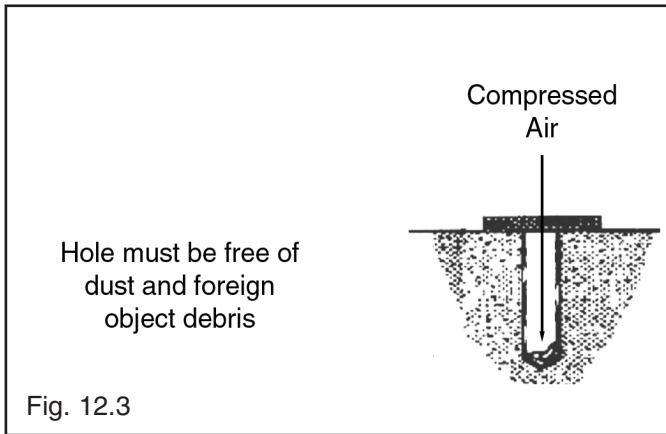

5. Assemble the washers and nuts on the anchors then tap into each hole with a hammer until the washer rests against the base. (See Fig. 12.4 - 12.5)

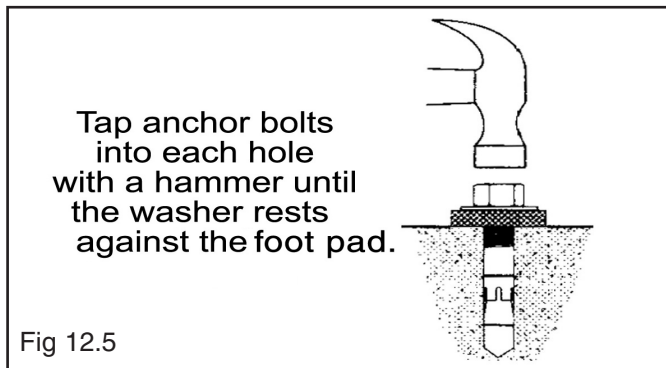
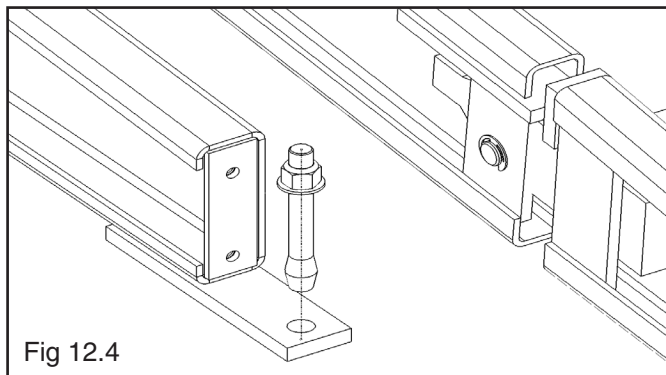

6. With the anchor bolts in place, tighten nut three to five turns past finger tight. DO NOT use an impact wrench for this procedure. (See Fig. 12.6)

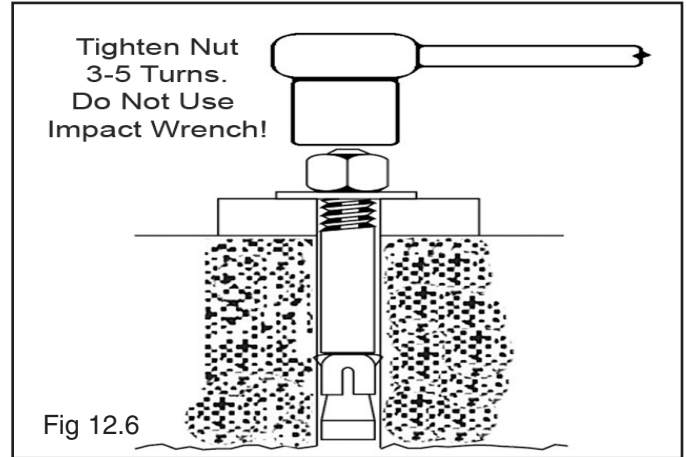

7. The Post restraints (if any were used) may now be removed.

8. Attach the Tire Guard Weldments using M10 x 25 hex bolts, nuts and washers. Make sure that the open side of the Guard faces the OUTSIDE of the lift. (See Fig 12.7)

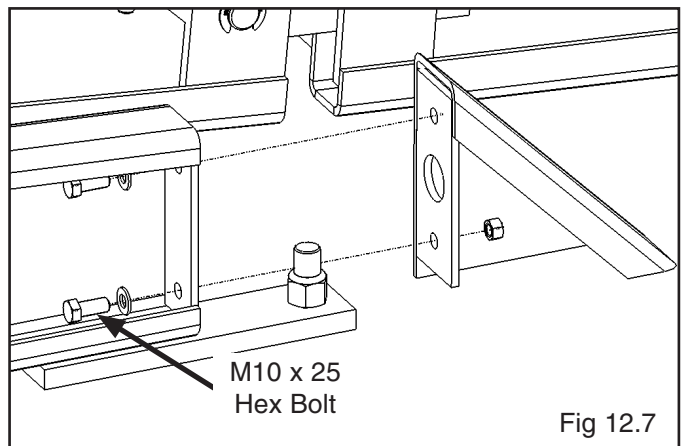



DANGER!

DO NOT PERFORM ANY MAINTENANCE OR INSTALLATION OF ANY COMPONENTS WITHOUT FIRST ENSURING THAT ELECTRICAL POWER HAS BEEN DISCONNECTED AT THE SOURCE OR PANEL AND CANNOT BE RE-ENERGIZED UNTIL ALL MAINTENANCE AND/OR INSTALLATION PROCEDURES ARE COMPLETED.

IMPORTANT POWER-UNIT INSTALLATION NOTES

- DO NOT run power unit without oil. Damage to pump can occur.
- The power unit must be kept dry. Damage to power unit caused by water or other liquids such as detergents, acid etc., is not covered under warranty.
- Improper electrical connection can damage motor and will not be covered under warranty.
- Motor can not run on 50HZ without a physical change in the motor.
- Use a separate breaker for each power unit.
- Protect each circuit with time delay fuse or circuit breaker.
- For 208-230 volt, single phase, use a 25 amp fuse.
- For 208-230 volt, three phase, use a 20 amp fuse.

Installation and adjustment:

DO NOT attempt to raise vehicle until a thorough operation check has been completed.

All wiring must be performed by a certified electrician.

24V with Transformer (2 wires not used)

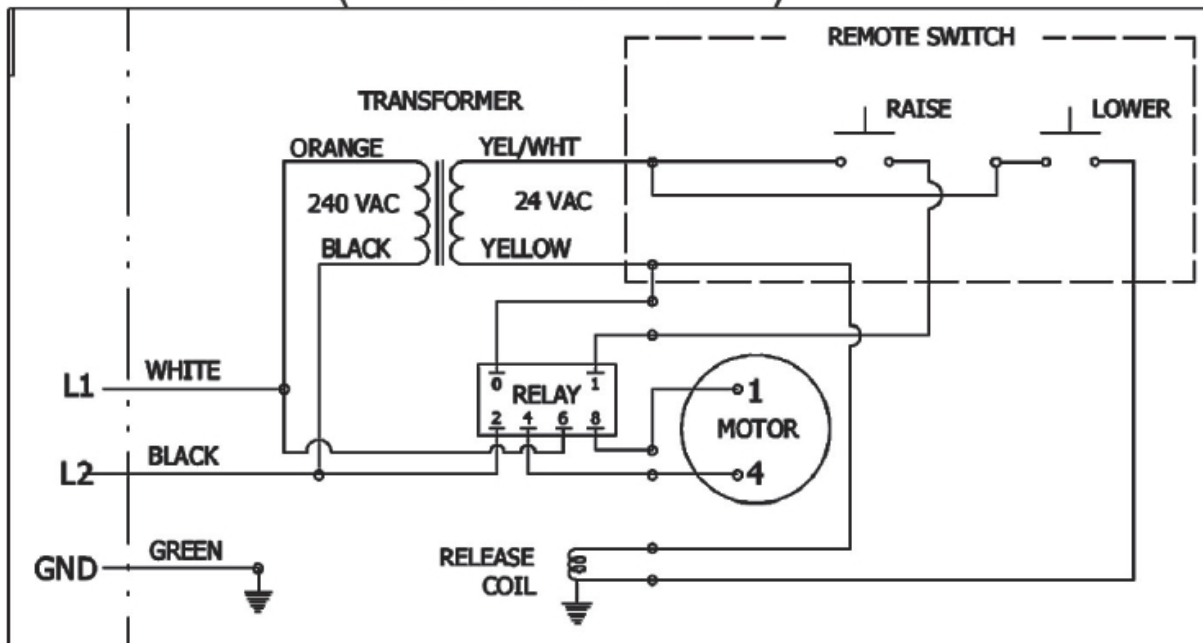

PLT-6 Wiring Diagram
208-230VAC, 1 Ph

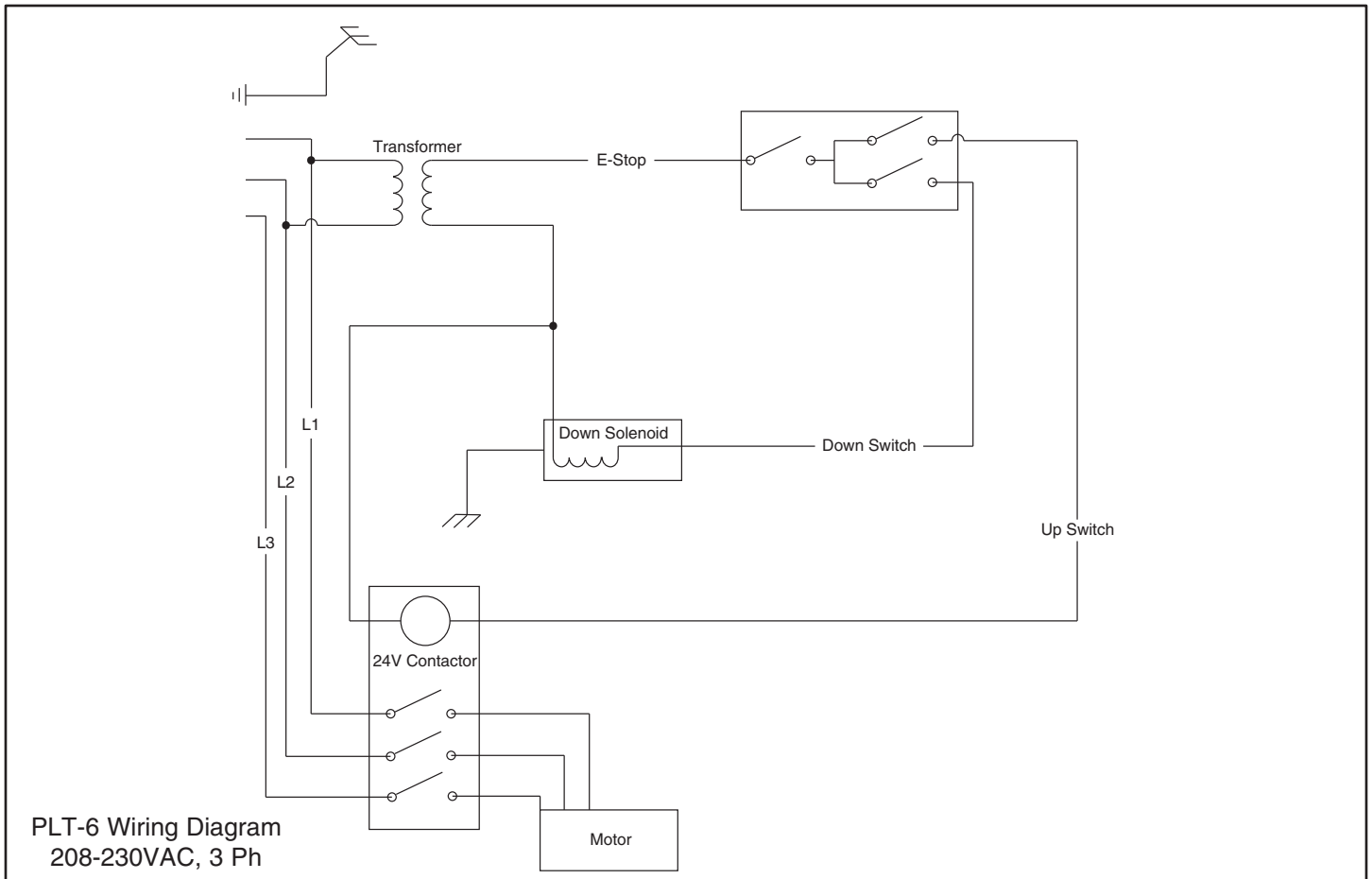

**STEP 13
(Power Unit Electrical Connection)**



DANGER !
ALL WIRING MUST BE PERFORMED
BY A LICENSED ELECTRICIAN.



DANGER!
RISK OF EXPLOSION! THIS EQUIPMENT HAS
INTERNAL ARCING OR PARTS THAT MAY SPARK
AND SHOULD NOT BE EXPOSED TO FLAMMABLE
VAPORS. MOTOR SHOULD NOT BE LOCATED IN
A RECESSED AREA OR BELOW FLOOR LEVEL.
NEVER EXPOSE MOTOR TO RAIN OR OTHER DAMP
ENVIRONMENTS. DAMAGE TO MOTOR CAUSED BY
WATER IS NOT COVERED UNDER WARRANTY.

1. Have a certified electrician run the power supply to motor. Refer to the data plate found on the motor for proper power supply and wire size. SEE WIRING INSTRUCTIONS AFFIXED TO MOTOR FOR PROPER WIRING INSTRUCTIONS.



WARNING!
DO NOT RUN POWER UNIT WITHOUT OIL. DAMAGE TO
POWER UNIT PUMP CAN OCCUR. THE POWER UNIT
MUST BE KEPT DRY. DAMAGE TO POWER UNIT CAUSED
BY WATER OR OTHER LIQUIDS SUCH AS DETERGENTS,
ACID ETC., IS NOT COVERED UNDER WARRANTY.

OPERATE LIFT ONLY BETWEEN TEMPERATURES OF
41 ° - 104° F. IMPROPER ELECTRICAL HOOK-UP CAN
DAMAGE MOTOR AND WILL NOT BE COVERED UNDER
WARRANTY. MOTOR CAN NOT RUN ON 50HZ WITHOUT
A PHYSICAL CHANGE IN THE MOTOR.

USE A SEPARATE CIRCUIT BREAKER FOR EACH POWER
UNIT. PROTECT EACH CIRCUIT WITH TIME DELAY FUSE
OR CIRCUIT BREAKER.

FOR 208-230 VOLT, SINGLE PHASE, USE A 25 AMP FUSE.
FOR 208-230 VOLT, THREE PHASE, USE A 20 AMP FUSE.

STEP 14 (Hydraulic, Air and Electrical Line Routing)

1. Mount the Power Unit and Vibration Dampener to the Power Unit Post Weldment using the M8 hex bolts and Nylock Nuts. Fill the reservoir with 4 gallons of 10-WT hydraulic oil or Dexron III automatic transmission fluid. (See Fig. 14.1)

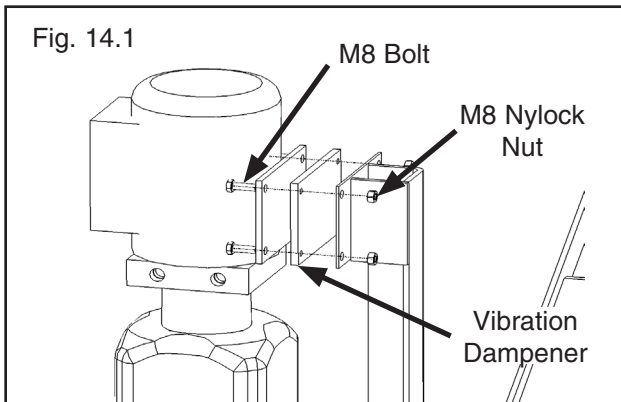

2. Remove the shipping plugs from both ports prior to installing the fittings. Install the 90° Hydraulic Fitting to the POWER PORT and the 90° Air Fitting to the RETURN PORT of the Power Unit. On the pipe thread side of the Air Fitting it is recommended to use Teflon tape or pipe sealer. (See Fig. 14.2)

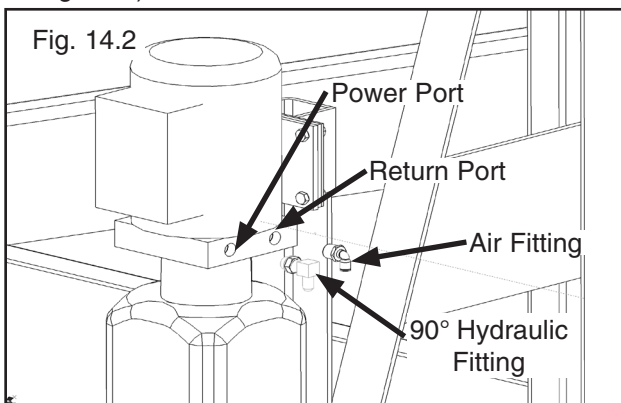

3. Connect one end of the Power Side Hose and the 90° end of the Off Side Hose to the Tee Fitting. Connect the Male-to-Female 90° fitting to the tee Fitting. Connect the Power Unit Hose to the 90° fitting. (See Fig. 14.3)

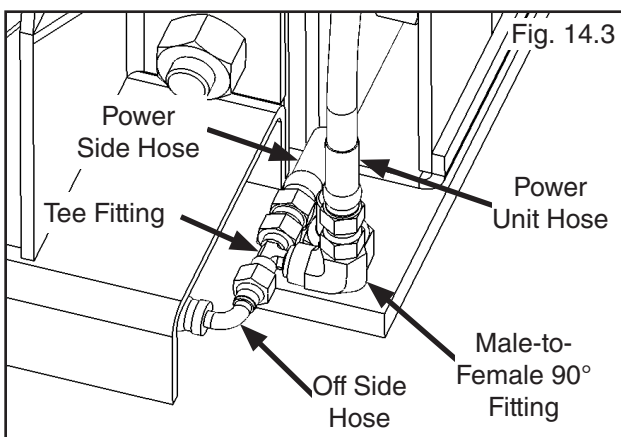

4. Route the Power Side and Off Side hoses through the Rubber Grommets that were installed in Step 10 and connect the hoses to the JIC elbow fittings on the cylinders. DO NOT use Teflon tape on the JIC fitting end. (See Fig. 14.4)

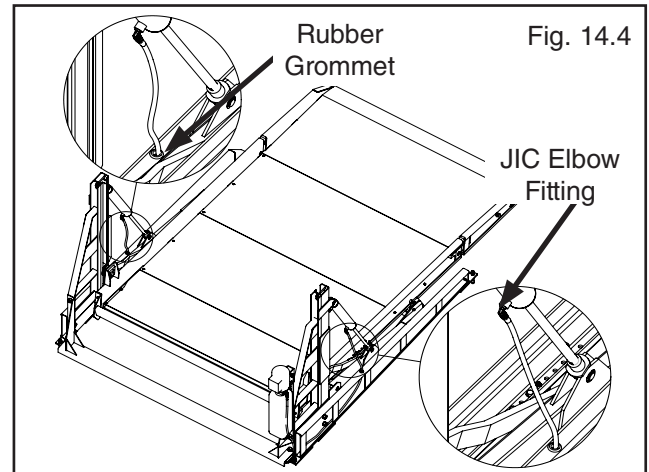

5. Connect the 1/4" air line tubing to the 90° Air Fittings and Air Tee Fitting using the same routes used for the Hydraulic Hoses. Cut the air line tubing with a sharp blade to lengths as required. Tubing must be cut square with no burrs.

Note: To assemble air line tubing into fittings, use firm, manual pressure to push tubing into the fitting until it bottoms out. To remove air line tubing from the fitting, hold push sleeve in (against fitting) and, at the same time, pull out on tubing. Pay careful attention to keep air line clear of any pinch points.

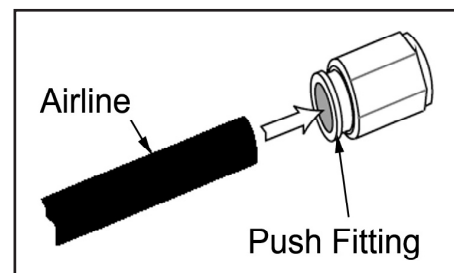

6. Install the provided Liquid Tight Conduit and Fittings. (See Fig 14.5)

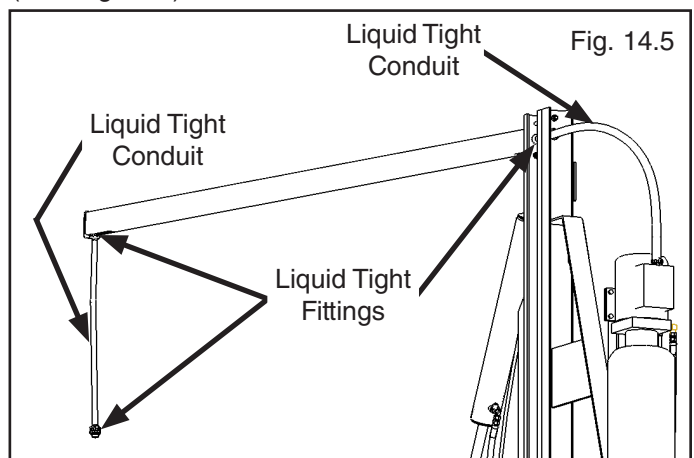

7. Route the Electrical Cable from the Control Pendant through the Control Arm Weldment and Conduit to the Power Unit and connect according to the wiring diagram found on page 22 and 23. (See Fig 14.6)

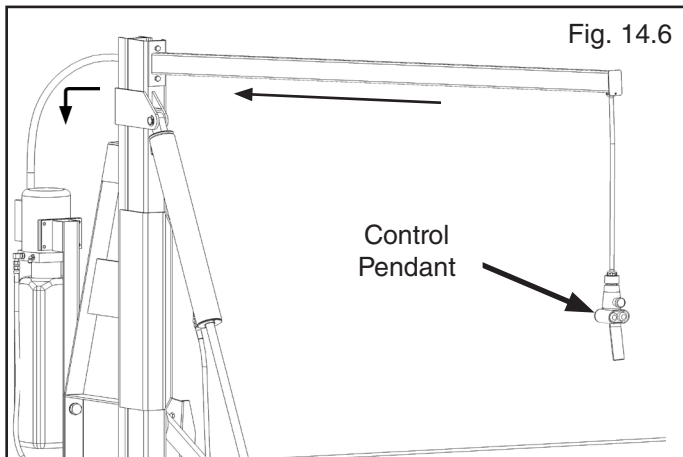

8. Ensure the Safety Placard is attached to the lift in plain view of the Control Pendant.

STEP 15 (Lift Start Up)

1. Make sure the Power Unit reservoir is full with four (4) gallons of 10-WT hydraulic oil or Dexron-III automatic transmission fluid.
2. Spray the inside of the posts with a light spray-oil.
3. Connect power supply and test the Power Unit by pressing the Up push-button switch on the Control Pendant. If the motor sounds like it is operating properly, raise the lift and check all hose connections for leaks. If the motor gets hot or sounds peculiar, STOP and check all electrical connections.
4. Raise lift until each cylinder is fully retracted and the lift stops. Place support stands or a fork lift underneath the ramp to support it during the next step.



DANGER!

Because the safety has not been installed yet, DO NOT work on or near raised lift until support stands are in place to support the platform. **Always** ensure support stands are engaged before any attempt is made to work on or near the lift / vehicle.

STEP 16 (Safety Installation)

1. With the ramp raised and supported securely, locate the Safety Weldment and Safety Bar Strap.

2. Place the Safety Weldment under the ramp so that the Safety Latches are completely on **BOTH** Safety Pins. Fasten the Safety Weldment to the Ramp Channels using the Safety Bar Straps and the provided M10 hex bolts and nylock nuts making sure the Straps are moved to the furthest outward position. (See Fig 16.1)

NOTE: It is recommended to bolt the Safety on the last position on the channels to ensure proper safety engagement.

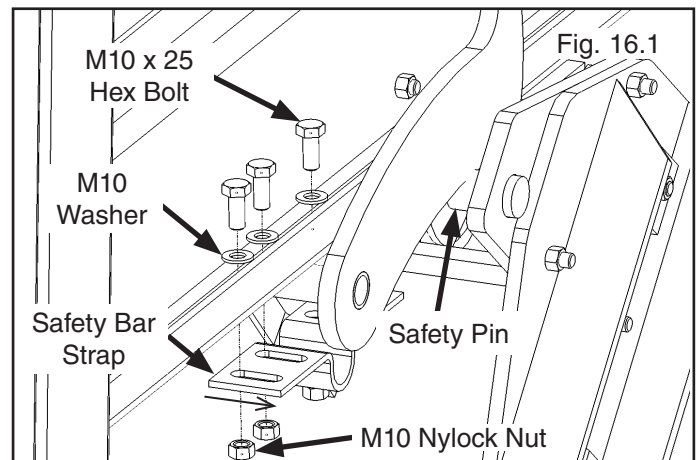

3. Once the Safety is connected to the lift, lower the lift by pressing the Down push button on the Control Pendant until the lift stops. The lift should now be resting on the safeties. If it is not, lower the lift all the way to the ground and make sure the lift did not shift during installation and test the safety again.

4. Install one Bulkhead Terminal in the hole in the Ramp Channel after the Safety Bar Strap and the other in the Cable Standoff Plate in the Drive Up ramp on the same side of the lift. (See Fig 16.2)

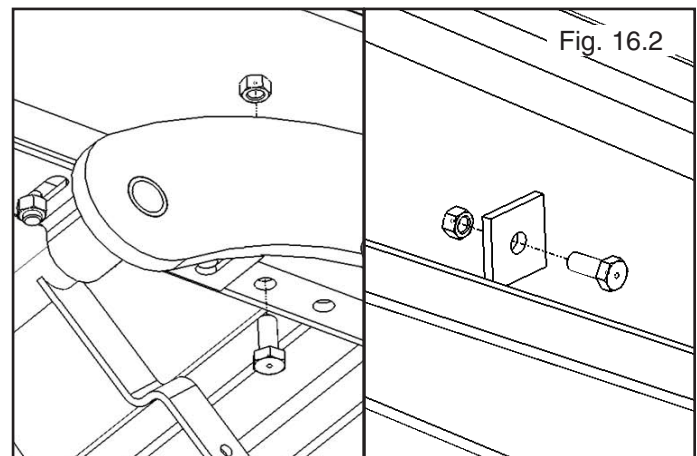

5. Locate the Safety Arm, Safety Wheel, Wire Rope Conduit Assembly and Safety Spring.

6. Attach the Safety Arm to the Drive Up Ramp using the M10 x 38 hex bolt, two jam nuts, spring lock washer and Small Spacer. (See Fig 16.3)

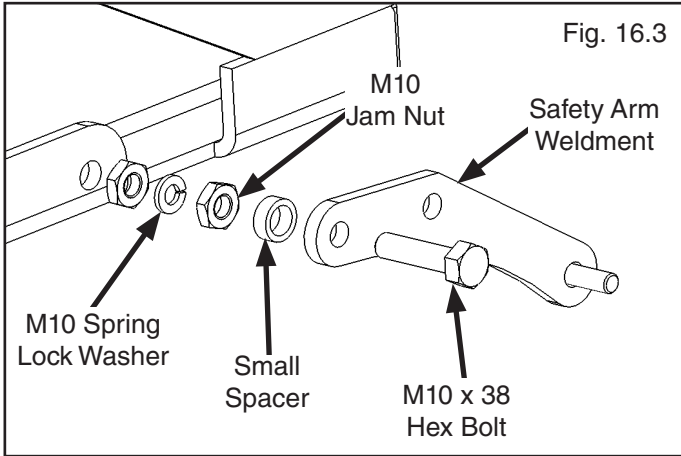

7. Assemble Safety Spring on the M10 x 50 hex bolt using a jam nut, nylock nut and Long Spacer. Assemble the Safety Wheel using the M8 nylock nut. (See Fig 16.4)

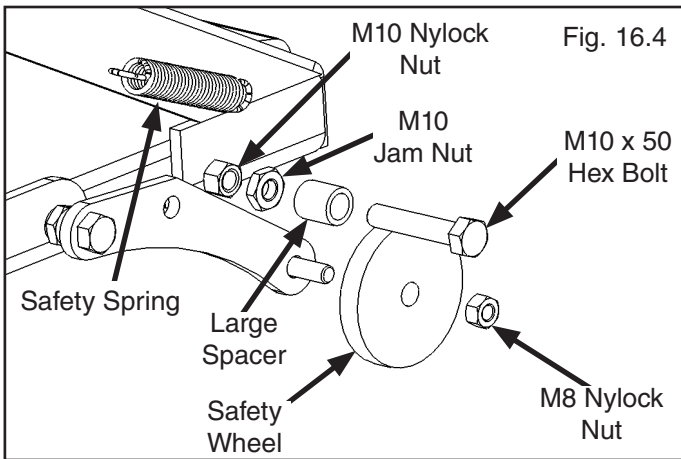

8. Insert the Wire Rope Conduit Assembly into the Drive Up Ramp Bulkhead Terminal and feed the push/pull cable through the small hole in its head. Slide the cable crimp on and make a small loop in the cable and crimp with pliers. After this is done, hook the spring to the cable. (See Fig 16.5)

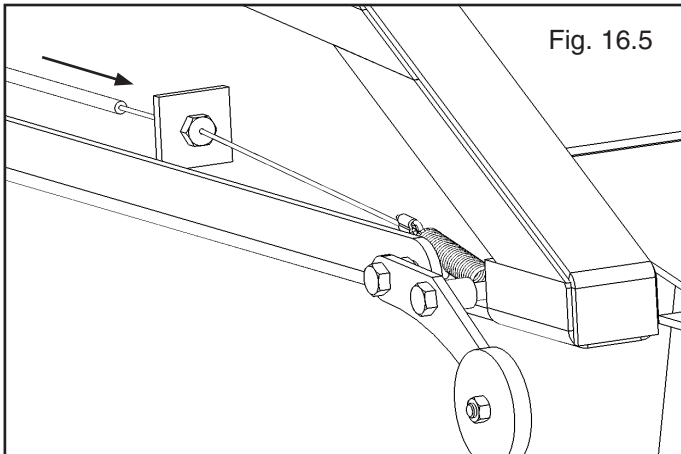

9. Insert the other end of the Wire Rope Conduit Assembly into the Ramp Channel Bulkhead Terminal and feed the push/pull cable through the small hole in its head. (See Fig 16.6)

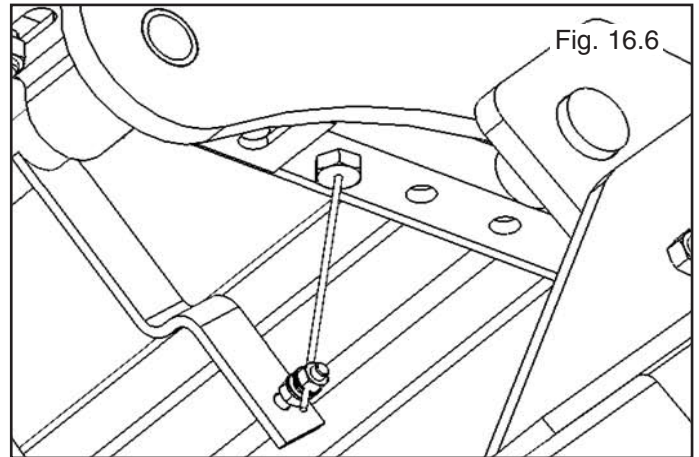

10. Thread one M6 hex nut and washer onto the threaded shaft past the hole in the shaft. Then insert the cable end through the hole. Thread the other nut and washer onto the shaft and tighten while making sure the cable is centered in the hole. (See Fig 16.7)

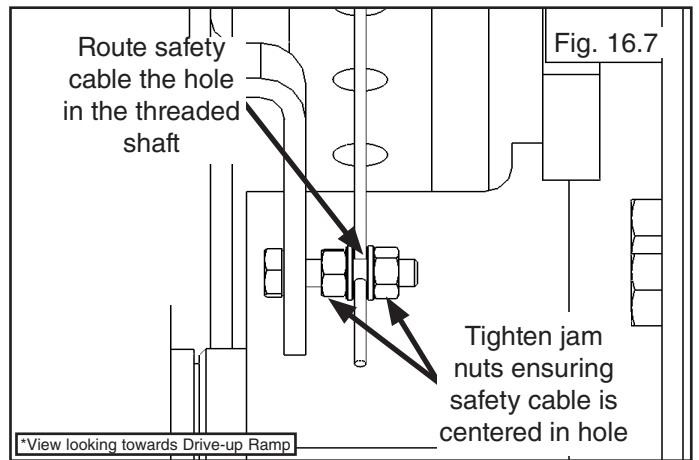

STEP 17 (Bleeding the Cylinder)

1. Lift must be fully lowered before changing or adding fluid.
2. Raise and lower lift six times. The cylinder is self-bleeding. After bleeding system, fluid level in Power Unit reservoir may be low. Add more fluid, if necessary, to raise lift to full height. It is only necessary to add fluid to raise lift to full height.
3. To pressure test, raise lift to full rise and run motor for approximately 3-seconds after lift stops. This will put pressure on the hydraulic system. Stop and check all fittings and hose connections. Tighten or reseal if required.

POST-INSTALLATION CHECKLIST

- Anchor bolts tightened
- Pivot pins properly attached
- Electric power supply confirmed
- Safety locks functioning properly
- Check for hydraulic leaks and oil level
- Lubrication of critical components
- Check for overhead obstructions
- All screws, bolts, and pins secured
- Surrounding area clear
- Safety Placard is attached to lift
- Operation, maintenance and safety manuals on site

STEP 18 (Operation)

To Raise Lift:

1. Load vehicle onto the lift as far forward on the lift as possible.
2. Set parking brake to hold vehicle in position.
3. Before raising vehicle, be sure all personnel are clear of the lift and surrounding area. Pay careful attention to overhead clearances.
4. Raise the lift to the Safety Lock height by pressing the UP button on the Control Pendant.
5. After vehicle is raised to the Safety Lock height, **lower the lift onto the safety lock** by pressing the DOWN button. **ALWAYS ENSURE ALL SAFETY LOCKS ARE ENGAGED** before entering lift area.

To Lower Lift:

1. Before lowering vehicle, be sure all personnel are clear of the lift and surrounding area. Pay careful attention to overhead clearances. Ensure all tools and equipment have been cleared from under the lift.

2. Raise the lift off of the safety locks by pressing the UP button on the Control Pendant. Make sure to raise the lift by at least two inches to allow adequate clearance for the locks to clear.

3. Manually release the Safety Arm by lowering it into the down position.



4. Push the DOWN BUTTON on the Control Pendant until the lift has descended completely.

When lowering the lift, **PAY CAREFUL ATTENTION** that all personnel and objects are kept clear. **ALWAYS** keep a visual line of sight on the lift **AT ALL TIMES. ALWAYS** make sure that **ALL LOCKS** are disengaged. If the locks inadvertently locks on descent, the lift and/or vehicle may disrupt causing personal injury or death.

Control Pendant

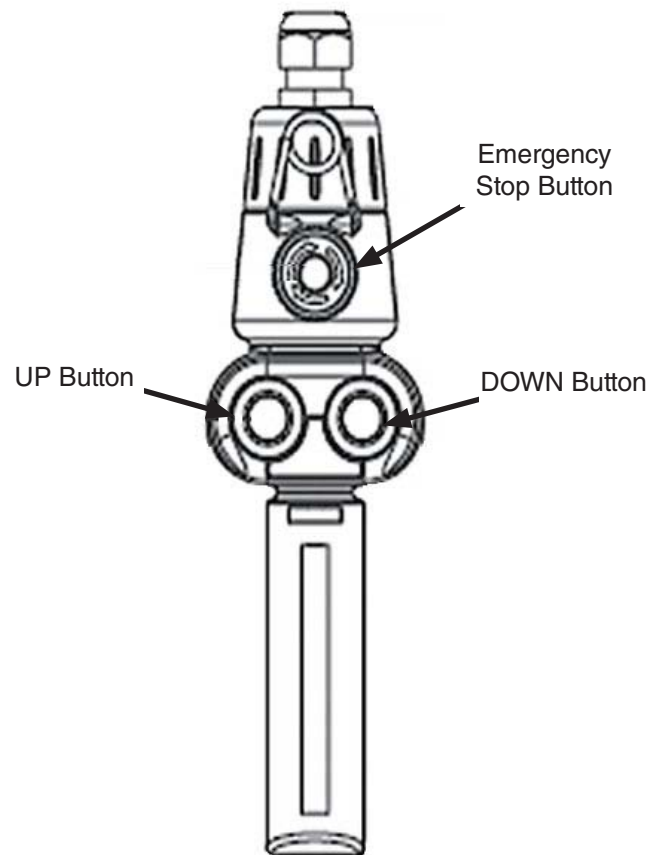

Safe Lift Operation

Automotive and truck lifts are critical to the operation and profitability of your business. The safe use of this and other lifts in your shop is critical in preventing employee injuries and damage to customer's vehicles. By operating lifts safely you can insure that your shop is profitable, productive and safe. Safe operation of automotive lifts requires that only trained employees should be allowed to use the lift.

TRAINING SHOULD INCLUDE, BUT NOT LIMITED TO:

- ◆ Proper positioning of the vehicle on the runway. (See manufacturers minimum wheel base loading requirements.)
- ◆ Use of the operating controls.
- ◆ Understanding the lift capacity.
- ◆ Proper use of jack stands or other load supporting devices.
- ◆ Proper use, understanding and visual identification of safety lock devices and their operation.
- ◆ Reviewing the safety rules.
- ◆ Proper housekeeping procedures. (Lift area should be free of grease, oil, tools, equipment, trash, and other debris.)
- ◆ A **daily** inspection of the lift should be completed prior to its use. Safety devices, operating controls, lift arms and other critical parts should be inspected prior to using the lift.
- ◆ All maintenance and repairs of the lift should be completed by following the manufacturer's requirements. Lift repair parts should meet or exceed OEM specifications. Repairs should only be completed by a qualified lift technician.
- ◆ The vehicle manufacturer's recommendations should be used for spotting and lifting the vehicle.

LIFT OPERATION SAFETY

- ◆ It is important that you know the load limit. Be careful that you do not overload the lift . If you are unsure what the load limit is, check the data plate found on one of the lift columns or contact the manufacturer.
- ◆ The center of gravity should be followed closely to what the manufacturer recommends.
- ◆ **Always** make sure you have proper overhead clearance. Additionally, check that attachments (vehicle signs, campers, antennas, etc.) are not in the way.
- ◆ Be sure that prior to the vehicle being raised, the doors, trunk, and hood are closed securely.
- ◆ Prior to being raised, make sure there is no one standing closer than six feet from the lift.
- ◆ After positioning the vehicle on the lift runways, set the emergency brake, make sure the ignition is off, the doors are closed, overhead obstructions are cleared, and the transmission is in park (neutral for manual transmissions).
- ◆ Double check that the automatic chock devices are in position, and then when the lift is raised, observe the chocks.
- ◆ The lift should be raised just until the vehicle's wheels are about one foot off the ground. If contact with the vehicle is uneven or it appears that the vehicle is not sitting secure, carefully lower the lift and readjust.
- ◆ **Always** consider potential problems that might cause a vehicle to slip, i.e., heavy cargo, undercoating, etc.
- ◆ Pay attention when walking under a vehicle that is up on the hydraulic lift.

Safe Lift Operation (Cont'd)



- ◆ **DO NOT** leave the controls while the lift is still in motion.
- ◆ **DO NOT** stand directly in front of the vehicle or in the bay when vehicle is being loaded or driven into position.
- ◆ **DO NOT** go near vehicle or attempt to work on the vehicle when being raised or lowered.
- ◆ **REMAIN CLEAR** of lift when raising or lowering vehicle.
- ◆ **DO NOT** rock the vehicle while on the lift or remove any heavy component from vehicle that may cause excessive weight shift.
- ◆ **DO NOT** lower the vehicle until people, materials, and tools are clear.
- ◆ **ALWAYS ENSURE** that the safeties are engaged and lowered onto the safety pins before any attempt is made to go near the bottom vehicle.
- ◆ **READ AND UNDERSTAND** all safety warning procedures before operating lift.
- ◆ **KEEP HANDS AND FEET CLEAR.** Remove hands and feet from any moving parts. Keep feet clear of lift when lowering. Avoid pinch points.
- ◆ **ONLY TRAINED OPERATORS** should operate this lift. All non-trained personnel should be kept away from work area. Never let non-trained personnel come in contact with, or operate lift.
- ◆ **USE LIFT CORRECTLY.** Use lift in the proper manner. Never use lifting adapters other than what is approved by the manufacturer.
- ◆ **DO NOT** override self-closing lift controls.
- ◆ **CLEAR AREA** if vehicle is in danger of falling.
- ◆ **STAY ALERT.** Watch what you are doing. Use common sense. Be aware.
- ◆ **CHECK FOR DAMAGED PARTS.** Check for alignment of moving parts, breakage of parts or any condition that may affect its operation. Do not use lift if any component is broken or damaged.
- ◆ **NEVER** remove safety related components from the lift. Do not use lift if safety related components are damaged or missing.
- ◆ When the lift is being lowered, make sure everyone is standing at least six feet away.
- ◆ Be sure there are no jacks, tools, or equipment left under the lift before lowering.
- ◆ **Always** lower the vehicle slowly and smoothly.

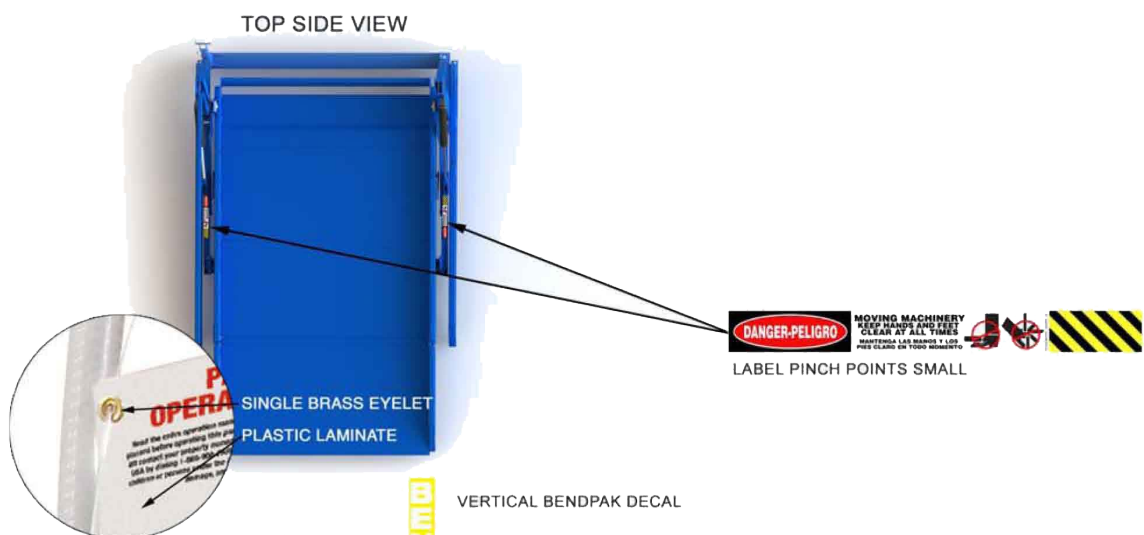
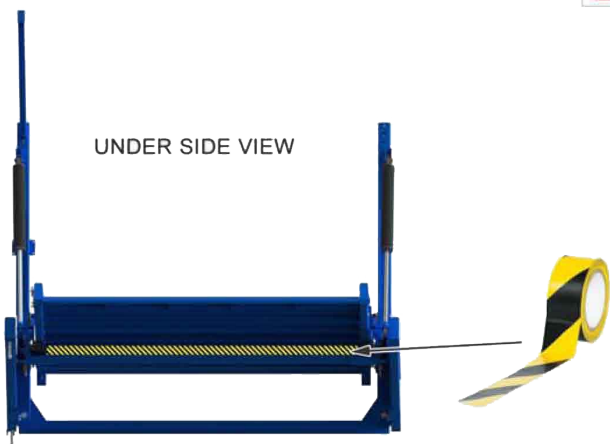
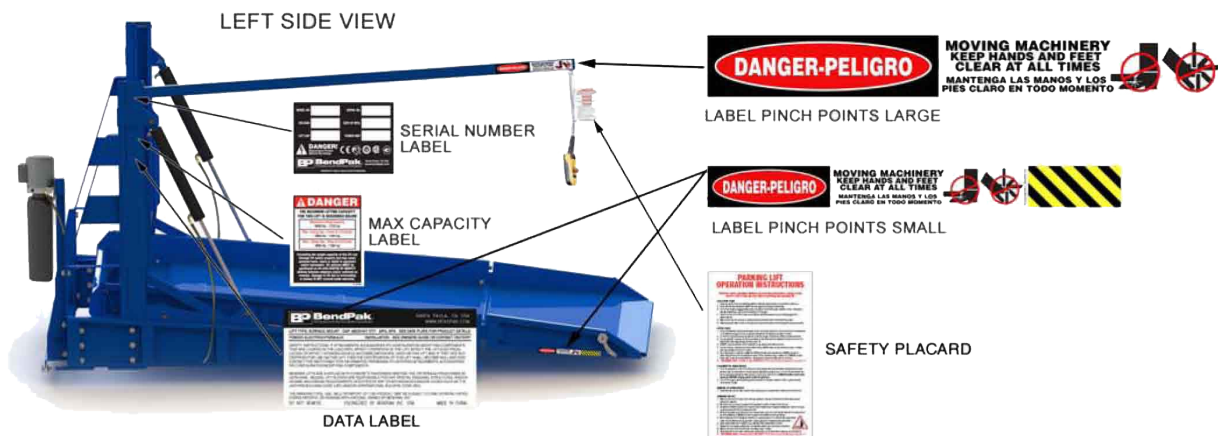

SAFETY INSTRUCTIONS



Read operating and safety manuals before using lift. ©

SAFETY INSTRUCTIONS



Proper maintenance and inspection is necessary for safe operation. ©

SAFETY INSTRUCTIONS

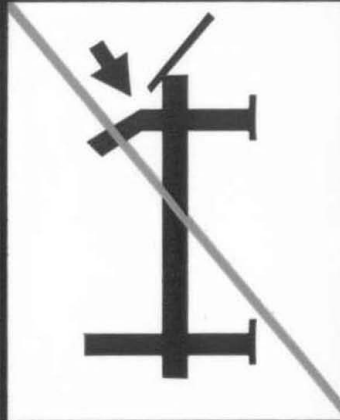

Do not operate a damaged lift. ©

The messages and pictographs shown are generic in nature and are meant to generally represent hazards common to all automotive lifts regardless of specific style.

Funding for the development and validation of these labels was provided by the Automotive Lift Institute, PO Box 33116 Indianalantic, FL. 32903.

They are protected by copyright. Set of labels may be obtained from ALI or its member companies.

© 1992 by ALI, Inc. ALI/WL2006

! DANGER

THE MAXIMUM LIFTING CAPACITY FOR THIS LIFT IS DESCRIBED BELOW

Maximum Lifting Capacity

6000 Lbs. / 2722 Kg.

Maximum Lifting Capacity / Front Axle

3000 Lbs. / 1361 Kg.

Maximum Lifting Capacity / Rear Axle(s)

3000 Lbs. / 1361 Kg.

Exceeding the weight capacity of this lift can damage lift and/or property and may cause personal harm, injury or death to operators and/or bystanders. All vehicles MUST be positioned on lift with CENTER OF GRAVITY midway between adapters and/or centered on runways. Damage to lift due to overloading or misuse IS NOT covered under warranty.

⚠ CAUTION



Lift to be used by trained operator only.

⚠ CAUTION



Authorized personnel only in lift area.

⚠ WARNING



Clear area if vehicle is in danger of falling.

⚠ WARNING



Position vehicle with center of gravity midway between adapters.

⚠ CAUTION

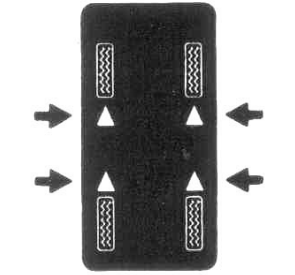

Use vehicle manufacturer's lift points.

⚠ CAUTION

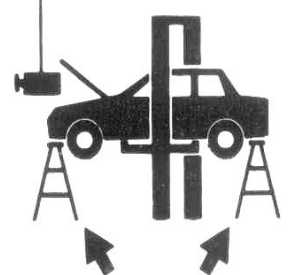

Always use safety stands when removing or installing heavy components.

⚠ WARNING



Remain clear of lift when raising or lowering vehicle.

⚠ WARNING



Avoid excessive rocking of vehicle while on lift.

⚠ CAUTION

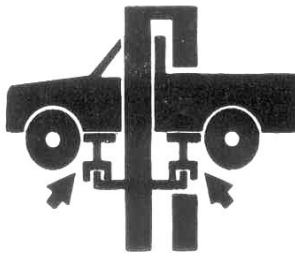

Use height extenders when necessary to ensure good contact.

⚠ CAUTION



Auxiliary adapters may reduce load capacity.

⚠ WARNING



Do not override self-closing lift controls.

⚠ WARNING

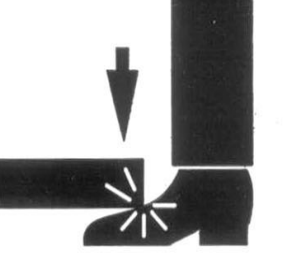

Keep feet clear of lift while lowering.

The messages and pictographs shown are generic in nature and are meant to generally represent hazards common to all automotive lifts regardless of specific style.

Funding for the development and validation of these labels was provided by the Automotive Lift Institute, PO Box 33116 Indialantic, FL. 32903.

They are protected by copyright. Set of labels may be obtained from ALI or its member companies.

© 1992 by ALI, Inc.

ALI/WL101c

The messages and pictographs shown are generic in nature and are meant to generally represent hazards common to all automotive lifts regardless of specific style.

Funding for the development and validation of these labels was provided by the Automotive Lift Institute, PO Box 33116 Indialantic, FL. 32903.

They are protected by copyright. Set of labels may be obtained from ALI or its member companies.

© 1992 by ALI, Inc.

ALI/WL101w

PARKING LIFT OPERATION WARNINGS

Read the entire operation manual, and operation instructions shown on the reverse side of this placard before operating this parking lift. If any questions arise as to the safety or operation of this lift contact your property manager, building engineer, local parking lift dealer or call BendPak at 1 (805) 933-9970. Always use caution when operating this lift. Never allow children or persons under the influence of drugs or alcohol to use this lift. Serious injury, property damage, and/or death can occur if this lift is improperly used.



ALWAYS double-check under clearance BEFORE driving vehicle under lift platform.



Never place any object or any part of your body on the legs or any other part of the lift during operation. Serious injury or death can occur.



- Read the entire operation manual before operating this parking lift.
- NEVER leave the lift unattended when it is partially raised or lowered.
- DO NOT raise the lift platform when the lift is empty. The lifts are designed to be lowered with the weight of a vehicle on the platform. Empty lifts will take much longer to lower.
- Always use caution when operating this lift. Never allow children or persons under the influence of drugs or alcohol to use this lift.
- Serious injury, property damage, and/or death can occur if this lift is improperly used.
- Keep hands and feet clear. Remove hands and feet from any moving parts. Keep feet clear of lift when lowering. Avoid pinch points.
- Only trained operators should operate this lift. All non-trained personnel should be kept away from work area. Never let non-trained personnel come in contact with, or operate lift.
- Guard against electric shock. This lift must be grounded while in use to protect the operator from electric shock.
- Risk of explosion. This lift has internal arcing or sparking parts which should not be exposed to flammable vapors.
- Maintain lift with care. Keep lift clean for better and safe performance. Follow manual for proper lubrication and maintenance instructions. Keep control handles and/or buttons dry, clean and free from grease and oil.
- Stay alert - watch what you are doing. Use common sense and always be aware.
- Check for damaged parts. Check for alignment of moving parts, breakage of parts or any condition that may affect safe operation of the lift. Do not use lift if any component is broken or damaged.
- Never remove safety related components from the lift. Do not use lift if safety related components are damaged or missing.

IMPORTANT NOTE

The custom lock-setting of the lift determines the height of the vehicles that can be safely parked underneath the lift. Make sure that you are using only vehicles that are of the proper height for the custom lock-setting. If the setting of your lift needs to be changed, contact your parking lift dealer.

PARKING LIFT OPERATION INSTRUCTIONS

Read the entire operation manual and warning instructions shown on the reverse side of this placard before operating this parking lift.

PRE-LIFTING STAGE

1. Drive top vehicle onto the elevating platform. Vehicles may be driven in nose first or backed in.
2. Drive until the top vehicle's forward tires rest against the forward wheel stop.
3. Turn off car engine, engage safety brake, and place the vehicle's gear selector in Park. If vehicle is manual transmission, place the transmission in first gear.
4. Walk to the rear of the platform and lift up on the red handle to engage the rear tire stops.
5. Check the front of the lift to make sure that the vehicle's forward tires are securely set against the wheel stop.
6. Walk around the lift to ensure no obstructions will interfere with the vehicle being lifted.
7. Position yourself in front of the lift within reach of the operator control console.

LIFTING STAGE

1. Once all precautions above are followed, check around and above the lift to ensure that no objects are in the platform's way, and that no persons (except the lift operator) are within 10 feet.
2. To raise the lift platform with top vehicle to desired height, turn the operator switch on the control console to the right position and hold.
3. During operation, observe the entire perimeter of the lift as well as overhead to ensure there are no obstructions that may damage vehicle and / or lift.
4. ALWAYS raise the platform until it reaches its top custom-set lock position.
5. If a low ceiling is overhead be careful when lifting. NEVER allow the top vehicle to come in contact with any overhead structure or object.
6. Once top position is reached, release the operator switch to its neutral position then turn and hold the operator switch to the left position to lower the platform with vehicle onto the lift's mechanical locks. Hold the operator switch in the left position until the platform is resting securely on the locks.
7. Walk around, never under the raised platform.

REMOVAL OF LOWER VEHICLE

1. Carefully drive out the lower vehicle after making sure all is clear before lowering the lift platform.

LOWERING THE LIFT

1. Walk around the lift to make sure nothing is below or near the lift platform's entire lower area to prepare for descent.
2. Be certain that no person (except the lift operator) is within 10 feet of the lift area.
3. Turn and hold the operator switch to the right position to elevate the lift approximately two inches or enough to allow release of the mechanical locks and release operator switch to its neutral position.
4. While pulling back and holding the lock release safety lever located below the control console, turn and hold the operator switch to the left position to lower the lift platform with top vehicle.
5. When lowering the lift always be watchful for objects, persons or animals that may wander under the lift platform during operation. Cease operation if area becomes obstructed.
6. KEEP HANDS AND FEET CLEAR OF ALL MOVING PARTS AND PINCH POINTS.
7. Release the lock release safety lever and operator switch upon full decent of platform.
8. Walk to the rear of the lift and lower the wheel stops / ramps.
9. Carefully drive out the lower vehicle after making sure all is clear before lowering the lift platform.



PLACEMENT OF LOWER VEHICLE

1. Once all precautions of the Pre-Lifting and Lifting Stage have been followed, drive the lower vehicle under the lift platform until the forward tires reach the front wheel bar, or, to the location where the car is properly positioned under the lift to allow clearance of the doors and mirrors.
2. Turn off the engine, set the parking brake and place in the gear selector in Park, or place manual transmission in gear.

P/N 5905569

LIFT WILL NOT RAISE

POSSIBLE CAUSE

1. Air in oil (1,2,8,13)
2. Cylinder binding (9)
3. Cylinder leaks internally (9)
4. Motor run backward under pressure (11)
5. Lowering valve leaks (3,4,6,10,11)
6. Motor runs backwards (7,14,11)
7. Pump damaged (10,11)
8. Pump won't prime (1,8,13,14,3,12,10,11)
9. Relief valve leaks (10,11)
10. Voltage to motor incorrect (7,14,11)

REMEDY

- | REMEDY | INSTRUCTION |
|---|--|
| 1. Check for proper oil level. | The oil level should be up to the bleed screw in the reservoir with the lift all the way down. |
| 2. Bleed cylinders. | See Installation Manual |
| 3. Flush release valve to get rid of possible contamination | Hold release handle down and start unit allowing it to run for 15 seconds. |
| 4. Dirty oil. | Replace oil with clean Dexron ATF. |
| 5. Tighten all fasteners. | Tighten fasteners to recommended torques (see chart on pg. 38). |
| 6. Check for free movement of release. | If handle does not move freely, replace bracket or handle assembly. |
| 7. Check if motor is wired correctly. | Compare wiring of motor to electrical diagram on drawing. |
| 8. Oil seal damaged or cocked | Replace oil seal around pump shaft. |
| 9. See Installation Manual | Contact BendPak Customer Support. |
| 10. Replace with new part | Replace with new part. |
| 11. Return unit for repair | Return unit for repair. |
| 12. Check pump-mounting bolts | Bolts should be 15 to 18 ft. lbs. |
| 13. Inlet screen clogged | Clean inlet screen or replace. |
| 14. Check wall outlet voltages and wiring | Make sure unit and wall outlet are wired properly. |

MOTOR WILL NOT RUN

POSSIBLE CAUSE

1. Fuse blown (5,2,1,3,4)
2. Limit switch burned out (1,2,3,4)
3. Microswitch burned out (1,2,3,4)
4. Motor burned out (1,2,3,4,6)
5. Voltage to motor incorrect (2,1,8)

REMEDY

- | REMEDY | INSTRUCTION |
|---|--|
| 1. Check for correct voltage | .Compare supply voltage with voltage on motor name tag. Check that the wire is sized correctly. N.E.C. table 310-12 requires AWG 10 for 25 Amps. |
| 2. Check motor is wired correctly | .Compare wiring of motor to electrical diagram on drawing. |
| 3. Don't use extension cords | .According to N.E.C. : " The size of the conductors... should be such that the voltage drop would not exceed 3% to the farthest outlet for power..." Do not run motor at 115 VAC – damage to the motor will occur. |
| 4. Replace with new part | .Replace with new part. |
| 5. Reset circuit breaker/fuse | .Reset circuit breaker/fuse. |
| 6. Return unit for repair | Return unit for repair. |
| 7. See Installation Manual | .See Installation Manual. |
| 8. Check wall outlet voltage and wiring | Make sure unit and wall outlet is wired properly. Motor must run at 208/230 VAC. |

LIFT LOWERS SLOWLY OR NOT AT ALL

POSSIBLE CAUSE

1. Cylinders binding, (1)
2. Release valve clogged, (5,4,2,3)
3. Pressure fitting too long, (6)

REMEDY

- | REMEDY | INSTRUCTION |
|---|--|
| 1. See Installation Manual | Contact BendPak Customer Support. |
| 2. Replace with new part | Replace with new part. |
| 3. Return for repair | Return for repair. |
| 4. Check oil. | Use clean 10-WT hydraulic oil or Dexron-III automatic transmission fluid only. If ATF is contaminated, replace with clean ATF and clean entire system. |
| 5. Clean release valve | Wash release valve in solvent and blow out with air. |
| 6. Replace fitting with short thread lead | Replace fitting with short thread lead. |

WILL NOT RAISE LOADED LIFT

POSSIBLE CAUSE

1. Air in oil (1,2,3,4)
2. Cylinder binding (5)
3. Cylinder leaks internally (5)
4. Lift overloaded (6,5)
5. Lowering valve leaks (7,8,1,5,9)
6. Motor runs backwards (10,12,9)
7. Pump damaged (5,9)
8. Pump won't prime (1,2,3,4,5,11,9)
9. Relief valve leaks (8,5,9)
10. Voltage to motor incorrect (10,12,5)

REMEDY

- | REMEDY | INSTRUCTION |
|--|--|
| 1. Check oil level | The oil level should be up to the bleed screw in the reservoir with the lift all the way down. |
| 2. Check/Tighten inlet tubes | Replace inlet hose assembly. |
| 3. Oil seal damaged or cocked | Replace oil seal and install. |
| 4. Bleed cylinders | See Installation Manual. |
| 5. See Installation Manual | Contact BendPak Customer Support. |
| 6. Check vehicle weight | Compare weight of vehicle to weight limit of the lift. |
| 7. Flush release valve | Hold release handle down and start unit allowing it to run for 15 seconds. |
| 8. Replace with new part | Replace with new part. |
| 9. Return unit for repair | Return unit for repair. |
| 10. Check motor is wired correctly | Compare wiring of motor to electrical diagram on power unit drawing. |
| 11. Inlet screen clogged | Clean inlet screen or replace. |
| 12. Check wall outlet voltage and wiring | Make sure unit and wall outlet is wired properly. |

LIFT WILL NOT STAY UP

POSSIBLE CAUSE

1. Air in oil (1,2,3)
2. Check valve leaks (6)
3. Cylinders leak internally (7)
4. Lowering valve leaks (4,5,1,7,6)
5. Leaking fittings (8)

REMEDY

1. Check oil level The oil level should be up to the bleed screw in the reservoir with the lift all the way down.
2. Oil seal damaged and cocked Replace oil seal around pump shaft.
3. Bleed cylinder Refer to Installation Manual.
4. Flush release valve Hold release handle down and start unit allowing it to run for 15 seconds.
5. Replace with new valve Replace with new valve.
6. Return unit for repair Return unit for repair.
7. See Installation Manual Contact BendPak Customer Support.
8. Check complete hydraulic system for leaks. Tighten all hydraulic fittings and inspect all hoses.

INSTRUCTION



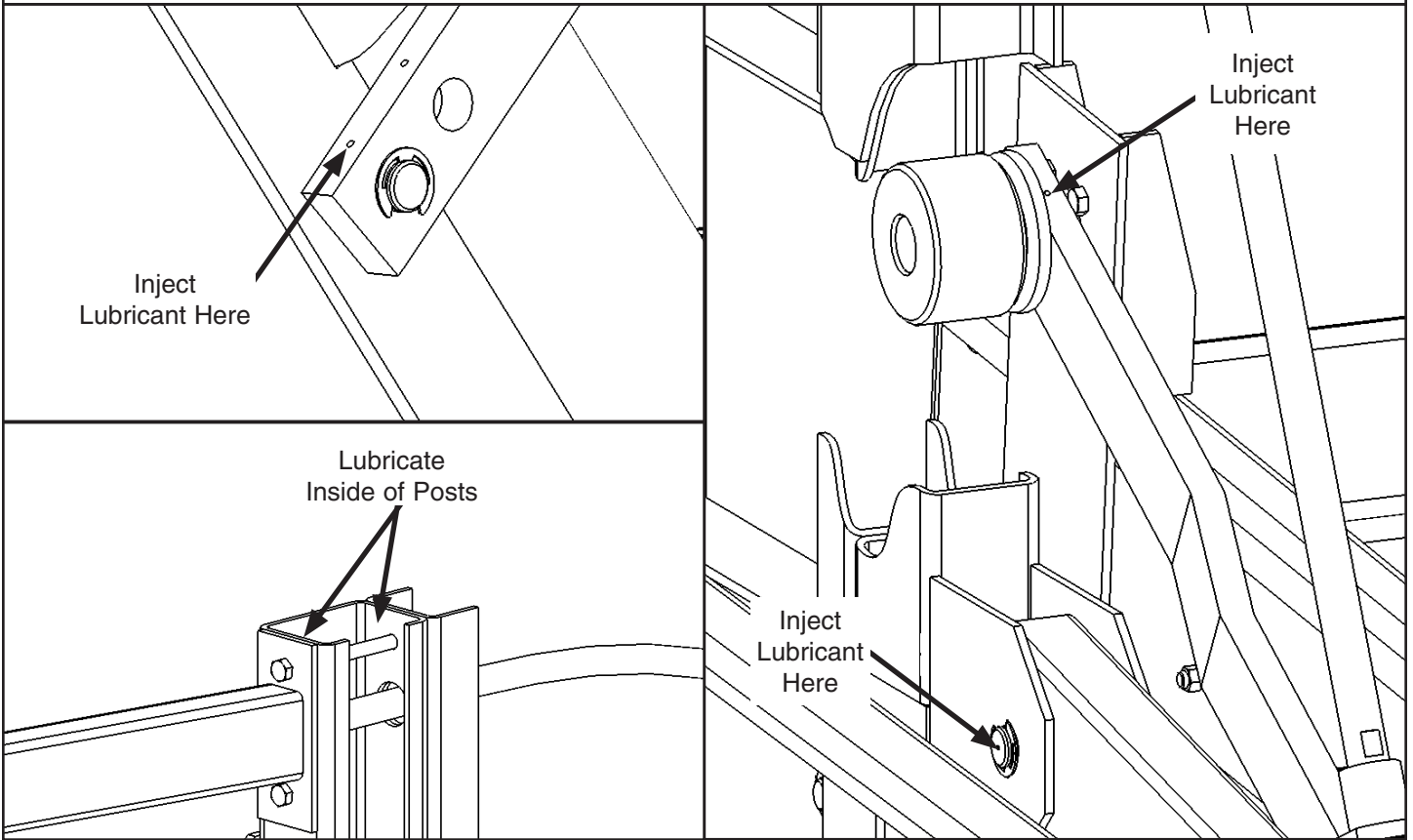

Lubrication Locations



NOTE: Lubrication procedure should be performed on both the right side and left side of the lift.

Torque Recommendations

VALUES ARE STATED IN FOOT POUNDS (ft-lb)

					
		SAE 0-1-2 CLASS 4.8	SAE Grade 5 CLASS 8.8	SAE Grade 8 CLASS 10.9	SOCKET HEAD CAP SCREW CLASS 12.9
Bolt Size (SAE)	Bolt Size (Metric)				
1/4-20	M6 x 1.0	6	10	14	13
5/16-18	M8 x 1.25	12	19	29	31.4
3/8-16	M10 x 1.50	20	33	47	62
7/16-14		32	54	78	
1/2-13	M12 x 1.75	47	78	119	108
9/16-12	M14 x 2.00	69	114	169	173
5/8-11	M16 x 2.00	96	154	230	269
3/4-10	M18 x 2.50	155	257	380	372
7/8-9	M22 x 2.50	206	382	600	716
3/4 Anchor Bolts		75 MIN 110 MAX			

Maintenance

If you are not completely familiar with parking lift maintenance procedures STOP and contact factory or lift dealer for instructions. To avoid personal injury, permit only qualified personnel to perform maintenance on this equipment.

- **Always** check and adjust all bolts that may be loose. Keep bolts tight.
- **Always** keep lift components clean. Clean off the platform and all areas susceptible to debris.
- **Always**, if oil leakage is observed, call local service representative.
- **Always**, if electrical problems develop, call local service representative.
- **Daily**: Check all moving parts for wear. Replace worn parts as required with genuine BendPak parts.
- **Daily**: Inspect entire lift and all moving components for damage or excessive wear. Replace as required with genuine BendPak parts.
- **Monthly**: Check safety lock operation. Adjust per lift installation instructions.
- **Monthly**: Use a heavy weight axle bearing grease on all pins and pivot points.
- **Monthly**: Check hydraulic connections for leaks.
- **Monthly**: Lubricate locking latch pivot points. Operate handle several times for oil to penetrate pivot points.
- **Every 3 Months**: Check anchor bolts for tightness. Anchors should torque to 90 ft/lbs.
- **Semi-Annually**: Check fluid level of lift power unit and refill if required per lift installation instructions.
- **Replace** all caution, warning or safety related decals on the lift if unable to read or missing. Reorder labels from factory or lift dealer.
- **Replace** hydraulic fluid with AW Type 32 every 5 to 10 years, depending on frequency of use

If replacement parts need to be used in order to return the Car Lift to factory operating condition, please contact factory or lift dealer to obtain these parts. Please use only factory original components to ensure safe operation.

INSTALLATION FORM

Customer Name:		Date of Installation:
Company Name:		
Street Address:		
City:	State:	Zip:
Phone:	Fax:	

Pre-Install Agreement

I, (the undersigned) acting as the owner of the business listed above assume responsibility for any permits required, either state or county mandated, related to the installation and/or operation of this equipment. I assume responsibility for the concrete floor and condition thereof, now or later, where the above equipment model(s) are installed. I will assume all liability for losses, damages (including loss of use), expenses, demands, claims, and judgments in connection with or arising out of any personal injury or alleged damage to property, sustained or alleged to have been sustained in connection with, or to have arisen out of the condition and/or drilling of the concrete near or adjacent to the equipment model(s) listed above. If my employee(s) offer assistance of any kind during installation of the above equipment model(s) I hold the manufacturer and installation company harmless of all liability for losses, damages, expenses, claims, and judgments in connection with or arising out of any personal injury or alleged damage to property, sustained or alleged to have been sustained in connection with the installation of the above equipment model(s).

I understand that the lifts above are supplied with concrete fasteners meeting the criteria of the American National Standard "Automotive Lifts - Safety Requirements for Construction, Testing, and Validation" ANSI/ALI ALCTV-1998, and that I will be responsible for all charges related to any special regional structural and/or seismic anchoring requirements specified by any other agencies and/or codes such as the Uniform Building Code (UBC) and/or International Building Code (IBC).

Customer Signature: _____ Print Name: _____ Date: _____

Post-Installation Check-Off

- | | |
|---|---|
| <input type="checkbox"/> Base and Columns Properly Shimmed And Stable | <input type="checkbox"/> Lubrication of Critical Components |
| <input type="checkbox"/> Anchor Bolts Tightened | <input type="checkbox"/> Lift Adapters |
| <input type="checkbox"/> Runways Properly Attached and Secured | <input type="checkbox"/> Check For Overhead Obstructions |
| <input type="checkbox"/> Electric Power Supply Confirmed | <input type="checkbox"/> Runways Level |
| <input type="checkbox"/> Cables / Chains Adjusted Properly | <input type="checkbox"/> All Screws, Bolts, and Pins Secured |
| <input type="checkbox"/> Safety Locks Functioning Properly | <input type="checkbox"/> Surrounding Area and Lift Clean In Appearance |
| <input type="checkbox"/> Check For Hydraulic Leaks | <input type="checkbox"/> Proper Operation, Maintenance and Safety Explained |
| <input type="checkbox"/> Oil Level | <input type="checkbox"/> Operation and Safety Manual(s) Left at Site |

I, (the undersigned) confirm that the above installation procedure(s) were completed. I understand that I will be responsible for maintaining this equipment as outlined in the accompanied **Installation and Operation Manual** and **ANSI/ALI ALOIM Safety Requirements for Operation, Inspection and Maintenance**. I understand that personal injury and/or damage to property can occur if the above equipment model(s) are not maintained or used improperly and take full responsibility for training my employees on proper use and maintenance of this equipment. I hold the manufacturer and installation company harmless of all liability for losses, damages (including loss of use), expenses, demands, claims, and judgments in connection with or related to improper use, improper training, or lack of required maintenance. I understand that the warranty does not cover replacement of parts worn or damaged due to normal use or lack of required maintenance

Customer Signature: _____ Print Name: _____ Date: _____

Installer Signature: _____ Print Name: _____ Date: _____

Installer Company Name: _____

Street Address: _____

City:	State:	Zip:
Phone:	Phone (Other):	

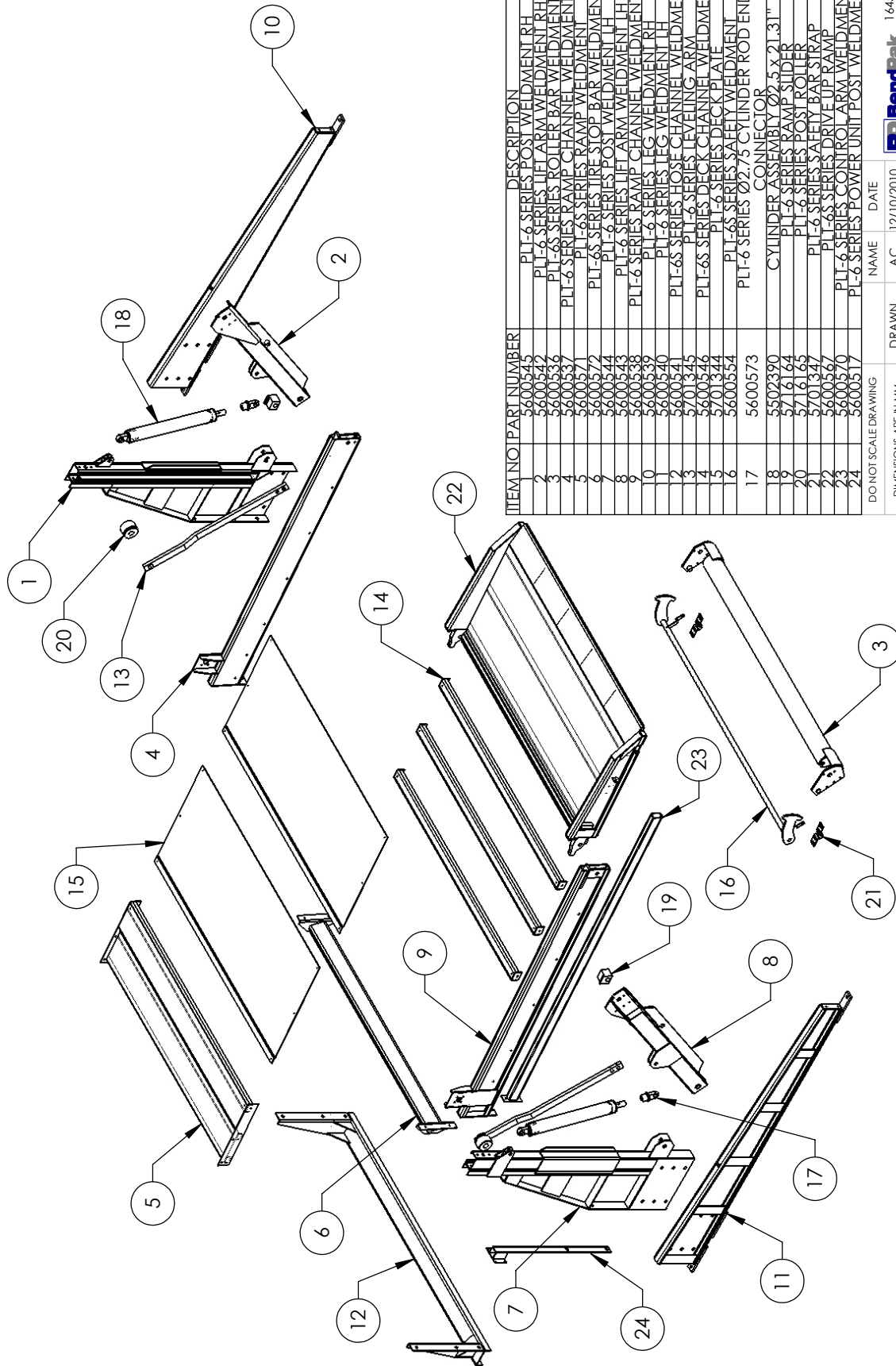

ITEM NO	PART NUMBER	DESCRIPTION	QTY	REV
1	5600545	PLT-6 SERIES POST WELDMENT RH	2	B
2	5600542	PLT-6 SERIES LIFT ARM WELDMENT RH	1	C
3	5600536	PLT-6 SERIES ROLLER BAR WELDMENT	1	B
4	5600537	PLT-6 SERIES RAMP CHANNEL WELDMENT RH	1	B
5	5600571	PLT-6S SERIES RAMP WELDMENT	1	A
6	5600572	PLT-6S SERIES TIRE STOP BAR WELDMENT	1	A
7	5600544	PLT-6 SERIES POST WELDMENT LH	2	B
8	5600543	PLT-6 SERIES LIFT ARM WELDMENT LH	1	C
9	5600538	PLT-6 SERIES RAMP CHANNEL WELDMENT LH	1	B
10	5600539	PLT-6 SERIES LEG WELDMENT LH	1	B
11	5600540	PLT-6 SERIES HOSE CHANNEL WELDMENT	2	A
12	5600541	PLT-6 SERIES LEVELING ARM	2	A
13	5701345	PLT-6S SERIES DECK CHANNEL WELDMENT	2	B
14	5600546	PLT-6S SERIES DECK PLATE	2	A
15	5701344	PLT-6S SERIES SAFETY WELDMENT	1	C
16	5600554	PLT-6 SERIES Ø2.75 CYLINDER ROD END	2	B
17	5600573	CONNECTOR	2	B
18	5502390	CYLINDER ASSEMBLY Ø2.5 X 21.31"	2	C
19	5716164	PLT-6 SERIES RAMP SLIDER	2	D
20	5716165	PLT-6 SERIES POST ROLLER	2	A
21	5701347	PLT-6 SERIES SAFETY BAR STRAP	2	A
22	5600567	PLT-6S SERIES DRIVE UP RAMP	1	B
23	5600570	PLT-6 SERIES CONTROL ARM WELDMENT	1	B
24	5600517	PLT-6 SERIES POWER UNIT POST WELDMENT	1	A

DO NOT SCALE DRAWING

DRAWN AC 12/10/2010

CHECKED

THIRD ANGLE PROJECTION

SMILEY FACE SYMBOL

MATERIAL: ---

SIZE: ---

PROPRIETY AND CONFIDENTIAL
THE INFORMATION CONTAINED HEREIN IS THE SOLE PROPERTY OF BENDPAK INC. ANY REPRODUCTION IN PART OR AS A WHOLE WITHOUT PERMISSION OF BENDPAK INC. IS PROHIBITED.

1645 LEMONWOOD DR.
SANTA PAULA, CA 93060

BendPak
POWER AND MATERIAL HANDLING

TITLE: PLT-6S LIFT SUPERSTRUCTURE

SIZE DWG. NO. A 5245235

REV E

SCALE: 1:40

SHEET 1 OF 1

NOTE: UNLESS OTHERWISE SPECIFIED, SEE SHIPPING INSTRUCTIONS FOR FINAL PACKAGING

NEXT ASSEMBLY 5240340

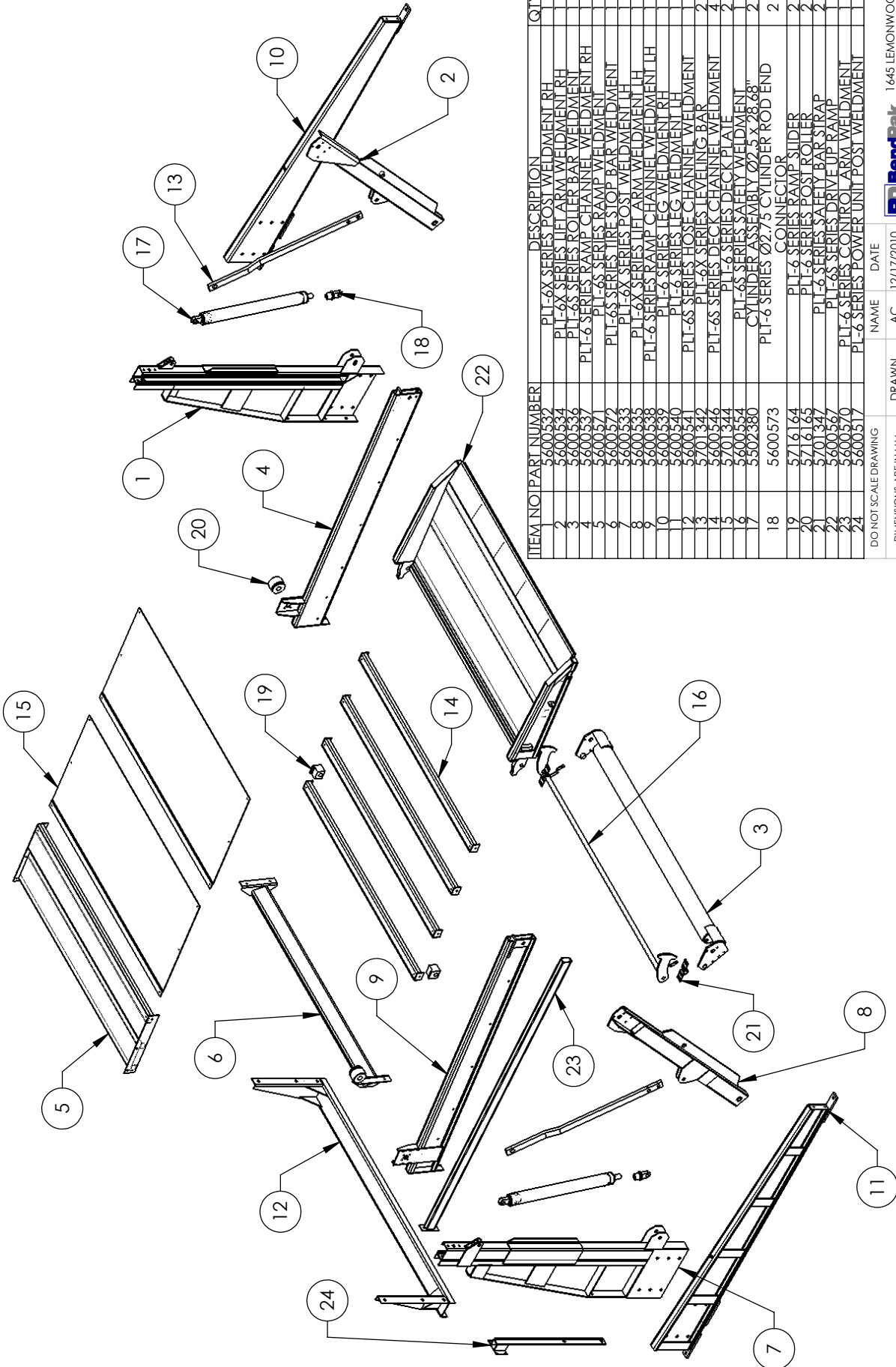

ITEM NO	PART NUMBER	DESCRIPTION	QTY	REV
1	5600532	PLT-6X SERIES POST WELDMENT RH	2	B
2	5600534	PLT-6X SERIES LIFT ARM WELDMENT RH	2	C
3	5600536	PLT-6X SERIES ROLLER BAR WELDMENT	2	B
4	5600537	PLT-6X SERIES CHANNEL WELDMENT RH	2	B
5	5600571	PLT-6X SERIES RAMP WELDMENT	2	A
6	5600572	PLT-6X SERIES TIRE STOP BAR WELDMENT	2	A
7	5600533	PLT-6X SERIES POST WELDMENT LH	2	B
8	5600535	PLT-6X SERIES LIFT ARM WELDMENT LH	2	C
9	5600538	PLT-6X SERIES RAMP CHANNEL WELDMENT LH	2	B
10	5600539	PLT-6X SERIES LEG WELDMENT RH	2	B
11	5600540	PLT-6X SERIES LEG WELDMENT LH	2	B
12	5600541	PLT-6X SERIES HOSE CHANNEL WELDMENT	2	A
13	5701342	PLT-6X SERIES LEVELING BAR	2	A
14	5600546	PLT-6X SERIES DECK CHANNEL WELDMENT	4	A
15	5701344	PLT-6X SERIES DECK PLATE	2	B
16	5600554	PLT-6X SERIES SAFETY WELDMENT	2	C
17	5502380	CYLINDER ASSEMBLY Ø2.5 x 28.68"	2	C
18	5600573	PLT-6X SERIES Ø2.75 CYLINDER ROD END	2	B
19	5716164	CONNECTOR	2	B
20	5716165	PLT-6X SERIES RAMP SLIDER	2	B
21	5701347	PLT-6X SERIES POST ROLLER	2	A
22	5600567	PLT-6X SERIES SAFETY BAR STRAP	2	C
23	5600570	PLT-6X SERIES DRIVE UP RAMP	2	B
24	5600570	PLT-6X SERIES CONTROL ARM WELDMENT	2	B
24	5600571	PLT-6X SERIES POWER UNIT POST WELDMENT	2	A

DO NOT SCALE DRAWING

NAME: _____ DATE: _____

DRAWN: AC 12/17/2010

CHECKED: _____

THIRD ANGLE PROJECTION

MATERIAL: _____

SIZE: _____

REVISIONS

REV	DESCRIPTION
A	5245236
E	

SCALE: 1:40

SHEET 1 OF 1

BendPak 1645 LEMONWOOD DR.
SANTA PAULA, CA 93060



NOTE: UNLESS OTHERWISE SPECIFIED, SEE SHIPPING INSTRUCTIONS FOR FINAL PACKAGING

NEXT ASSEMBLY
5240341

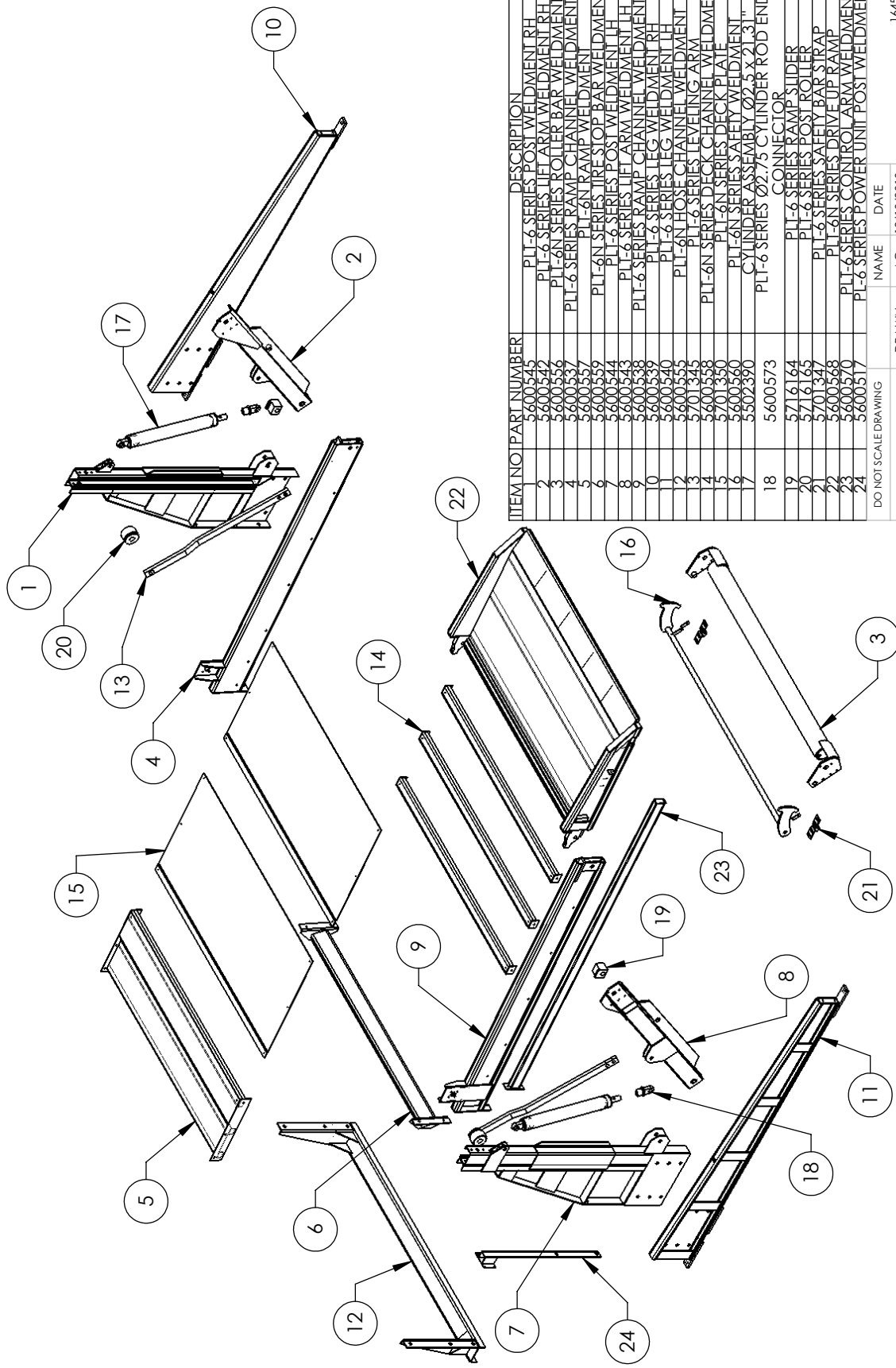

ITEM NO	PART NUMBER	DESCRIPTION	QTY	REV
1	5400545	PLT-6 SERIES POST WELDMENT RH	2	B
2	5400546	PLT-6 SERIES LIFT ARM WELDMENT RH	2	C
3	5400547	PLT-6N SERIES ROLLER BAR WELDMENT	2	B
4	5400548	PLT-6N SERIES RAMP CHANNEL WELDMENT RH	2	B
5	5400549	PLT-6N SERIES RAMP CHANNEL WELDMENT LH	2	B
6	5400550	PLT-6N SERIES RAMP WELDMENT	2	A
7	5400551	PLT-6N SERIES TIRE STOP BAR WELDMENT	2	A
8	5400552	PLT-6N SERIES POST WELDMENT LH	2	B
9	5400553	PLT-6N SERIES LIFT ARM WELDMENT LH	2	B
10	5400554	PLT-6N SERIES RAMP CHANNEL WELDMENT LH	2	B
11	5400555	PLT-6N SERIES LEG WELDMENT RH	2	B
12	5400556	PLT-6N SERIES LEG WELDMENT LH	2	B
13	5400557	PLT-6N HOSE CHANNEL WELDMENT	2	A
14	5400558	PLT-6N SERIES LEVELING ARM	2	A
15	5400559	PLT-6N SERIES DECK CHANNEL WELDMENT	2	B
16	5400560	PLT-6N SERIES SAFETY WELDMENT	2	C
17	5400561	PLT-6N SERIES SAFETY WELDMENT	2	C
18	5400562	CYLINDER ASSEMBLY Ø2.75 X 21.31"	2	C
19	5400563	PLT-6 SERIES Ø2.75 CYLINDER ROD END	2	B
20	5400564	CONNECTOR	2	B
21	5400565	PLT-6 SERIES RAMP SLIDER	2	B
22	5400566	PLT-6 SERIES POST ROLLER	2	A
23	5400567	PLT-6 SERIES SAFETY BAR STRAP	2	C
24	5400568	PLT-6N SERIES DRIVE UP RAMP	1	B
25	5400569	PLT-6N SERIES CONTROL ARM WELDMENT	1	B
26	5400570	PLT-6 SERIES POWER UNIT POST WELDMENT	1	A

DO NOT SCALE DRAWING

DIMENSIONS ARE IN MM

DRAWN AC 12/10/2010

CHECKED

THIRD ANGLE PROJECTION

NAME DATE

1645 LEMONWOOD DR.
SANTA PAULA, CA 93060

TITLE: PLT-6N LIFT SUPERSTRUCTURE

SIZE DWG. NO. A 5245237

REV E

SCALE: 1:40

SHEET 1 OF 1

PROPRIETARY AND CONFIDENTIAL
THE INFORMATION CONTAINED IN THIS DRAWING IS THE PROPERTY OF BENDPAK INC. AND IS TO BE USED ONLY FOR THE PROJECT AND IN THE MANNER AND FOR THE PERIOD SPECIFIED IN THE WRITTEN PERMISSION OF BENDPAK INC. IS PROHIBITED.

MATERIAL: ---

SIZE: ---

NEXT ASSEMBLY 5260342

NOTE: UNLESS OTHERWISE SPECIFIED, SEE SHIPPING INSTRUCTIONS FOR FINAL PACKAGING

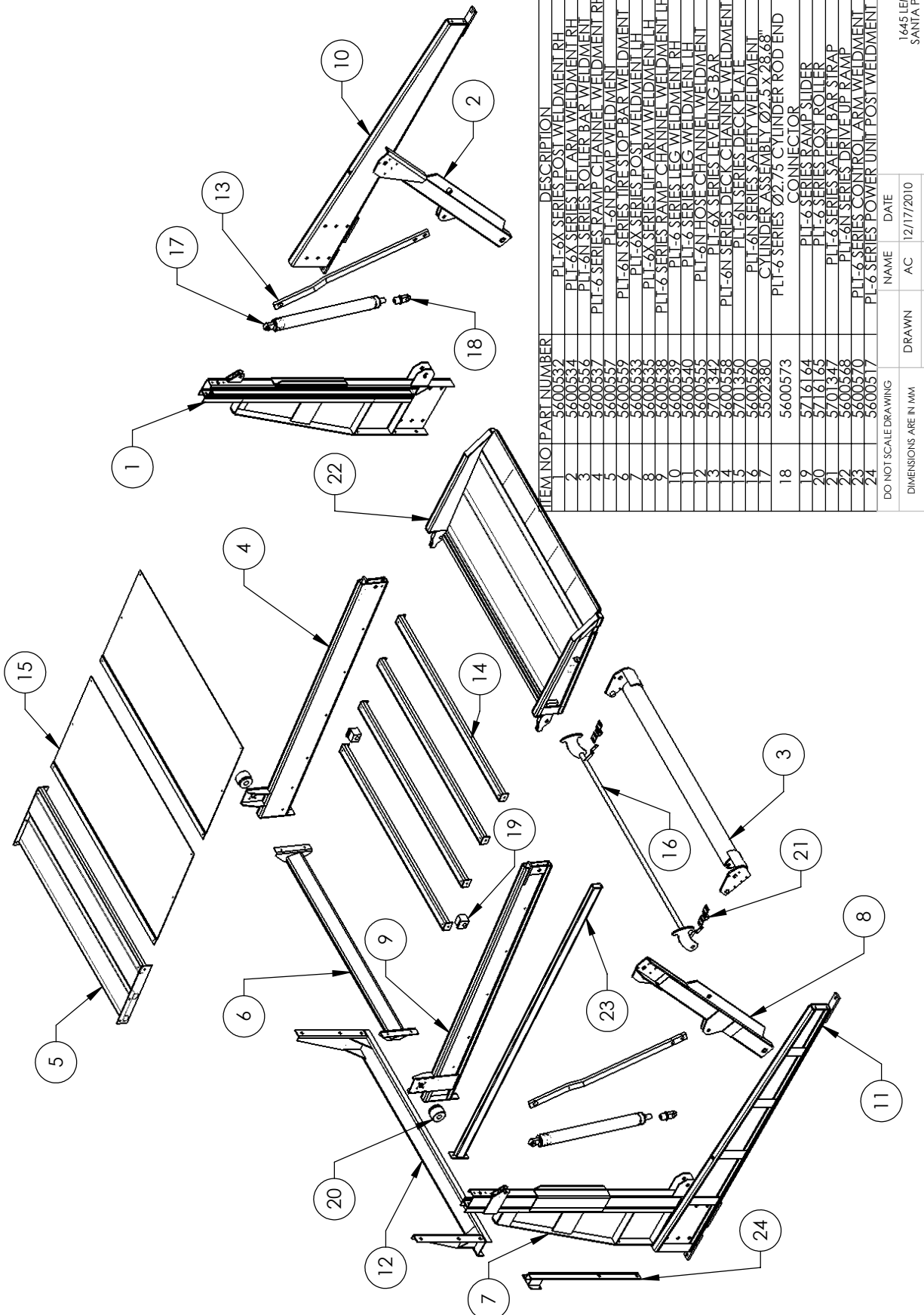

LEM NO	PART NUMBER	DESCRIPTION	QTY	REV
2	5600332	PLT-6X SERIES POST WELDMENT RH	2	B
3	5600334	PLT-6X SERIES LIFT ARM WELDMENT RH	2	B
4	5600336	PLT-6X SERIES POST RAMP WELDMENT	2	B
5	5600337	PLT-6X SERIES RAMP CHANNEL WELDMENT RH	2	B
6	5600337	PLT-6N RAMP WELDMENT	1	A
7	5600337	PLT-6N SERIES LIFT STOP BAR WELDMENT	1	B
8	5600333	PLT-6X SERIES LIFT ARM WELDMENT LH	2	B
9	5600335	PLT-6X SERIES LIFT ARM WELDMENT LH	2	B
10	5600338	PLT-6X SERIES RAMP CHANNEL WELDMENT LH	2	B
11	5600339	PLT-6X SERIES LEG WELDMENT RH	2	B
12	5600340	PLT-6X SERIES LEG WELDMENT LH	2	B
13	5600355	PLT-6N HOSE CHANNEL WELDMENT	2	A
14	5701342	PLT-6X SERIES LEVELING BAR	2	A
15	5600358	PLT-6N SERIES DECK CHANNEL WELDMENT	2	A
16	5701350	PLT-6N SERIES DECK PLATE	2	B
17	5600360	PLT-6N SERIES SAFETY WELDMENT	2	C
18	5600380	CYLINDER ASSEMBLY Ø2.5 X 28.68"	2	C
19	5600380	PLT-6X SERIES Ø2.75 CYLINDER ROD END	2	C
20	56003573	CONNECTOR	2	B
21	5716164	PLT-6X SERIES RAMP SLIDER	2	B
22	5716165	PLT-6X SERIES POST ROLLER	2	A
23	5701347	PLT-6X SERIES SAFETY BAR STRAP	2	A
24	5600568	PLT-6N SERIES DRIVE UP RAMP	1	B
25	5600570	PLT-6X SERIES CONTROL ARM WELDMENT	1	B
26	5600517	PLT-6X SERIES POWER UNIT POST WELDMENT	1	A

DO NOT SCALE DRAWING

DRAWN AC 12/17/2010

CHECKED

THIRD ANGLE PROJECTION

1645 LEMONWOOD DR.
SANTA PAULA, CA 93060

TITLE: PLT-6NX LIFT SUPERSTRUCTURE

SIZE DWG. NO. A 5245238

SCALE: 1:40

REV E

SHEET 1 OF 1

PROPRIETARY AND CONFIDENTIAL
THE INFORMATION CONTAINED IN THIS DRAWING IS THE PROPERTY OF BENDPAK INC. ANY REPRODUCTION IN PART OR AS A WHOLE WITHOUT THE WRITTEN PERMISSION OF BENDPAK INC. IS PROHIBITED.

MATERIAL: ---

SIZE: ---

NEXT ASSEMBLY 5280343

NOTE: UNLESS OTHERWISE SPECIFIED, SEE SHIPPING INSTRUCTIONS FOR FINAL PACKAGING

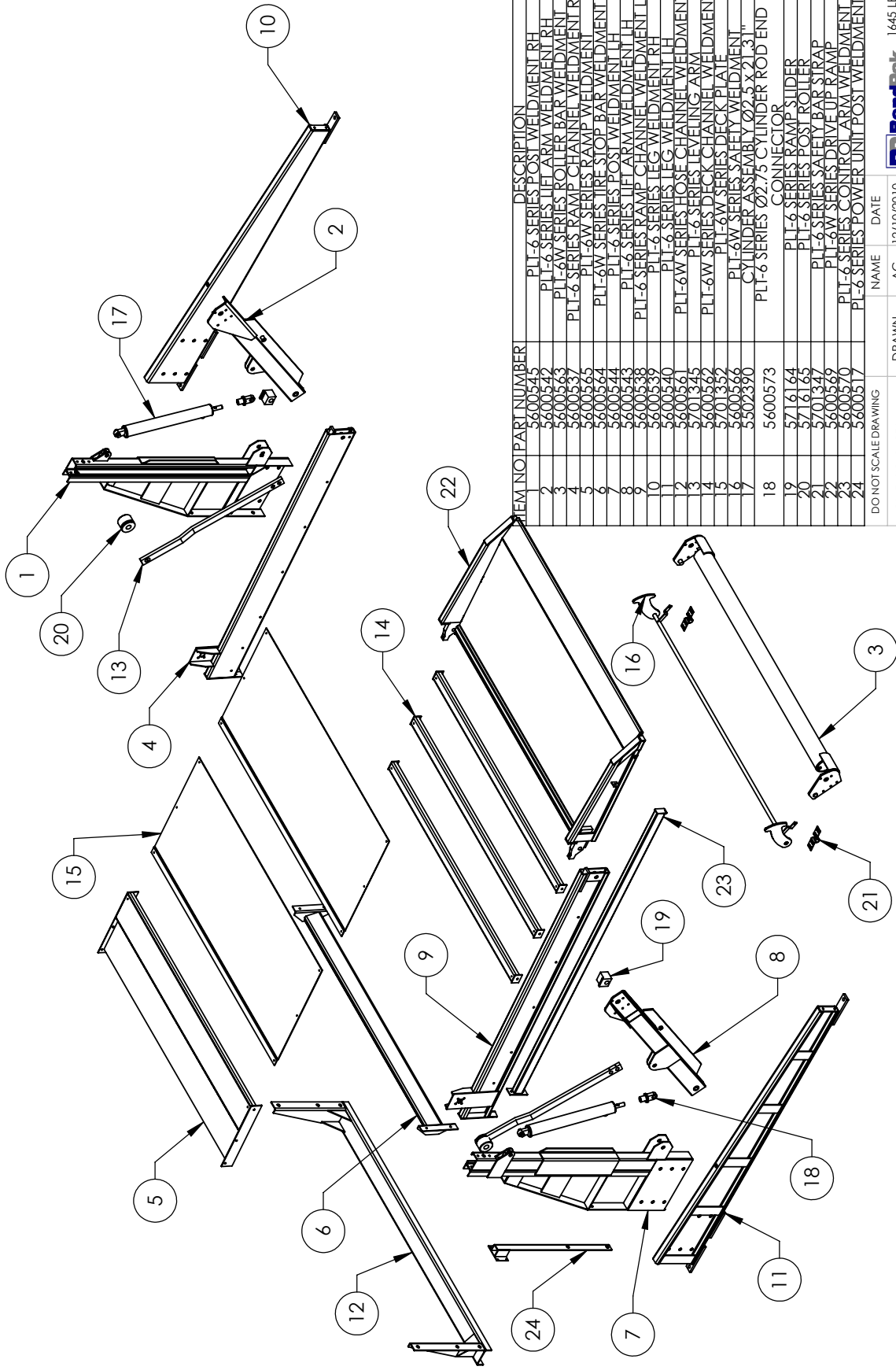

ITEM NO	PART NUMBER	DESCRIPTION	QTY	REV
1	5600545	PLT-6 SERIES POST WELDMENT RH	2	B
2	5600546	PLT-6 SERIES LIFT ARM WELDMENT RH	2	C
3	5600547	PLT-6W SERIES ROLLER BAR WELDMENT	1	B
4	5600548	PLT-6W SERIES HOSE CHANNEL WELDMENT RH	1	B
5	5600549	PLT-6W SERIES RAMP WELDMENT	1	B
6	5600550	PLT-6W SERIES RAMP WELDMENT LH	1	B
7	5600551	PLT-6W SERIES LIFT ARM WELDMENT LH	1	B
8	5600552	PLT-6W SERIES LEG WELDMENT LH	1	B
9	5600553	PLT-6W SERIES LEG WELDMENT RH	1	B
10	5600554	PLT-6W SERIES HOSE CHANNEL WELDMENT	1	A
11	5600555	PLT-6W SERIES LEVELING ARM	2	A
12	5600556	PLT-6W SERIES DECK CHANNEL WELDMENT	2	B
13	5600557	PLT-6W SERIES SAFETY WELDMENT	2	C
14	5600558	PLT-6W SERIES SAFETY WELDMENT	2	C
15	5600559	PLT-6W SERIES SAFETY WELDMENT	2	C
16	5600560	PLT-6W SERIES SAFETY WELDMENT	2	C
17	5600561	PLT-6W SERIES SAFETY WELDMENT	2	C
18	5600562	PLT-6W SERIES SAFETY WELDMENT	2	C
19	5600563	PLT-6W SERIES SAFETY WELDMENT	2	C
20	5600564	PLT-6W SERIES SAFETY WELDMENT	2	C
21	5600565	PLT-6W SERIES SAFETY WELDMENT	2	C
22	5600566	PLT-6W SERIES SAFETY WELDMENT	2	C
23	5600567	PLT-6W SERIES SAFETY WELDMENT	2	C
24	5600568	PLT-6W SERIES SAFETY WELDMENT	2	C

DO NOT SCALE DRAWING

DRAWN AC 12/10/2010

CHECKED

THIRD ANGLE PROJECTION

TITLE: PLT-6W LIFT SUPERSTRUCTURE

SIZE DWG. NO. A 5245239

SCALE: 1:40

REV E

SHEET 1 OF 1

1645 LEMONWOOD DR. SANTA PAULA, CA 93060

PROPRIETARY AND CONFIDENTIAL. THE INFORMATION CONTAINED HEREIN IS THE PROPERTY OF BENDPAK INC. REPRODUCTION IN PART OR AS A WHOLE WITHOUT PERMISSION OF BENDPAK INC. IS PROHIBITED.

INEXI ASSEMBLY 52603444

NOTE: UNLESS OTHERWISE SPECIFIED, SEE SHIPPING INSTRUCTIONS FOR FINAL PACKAGING

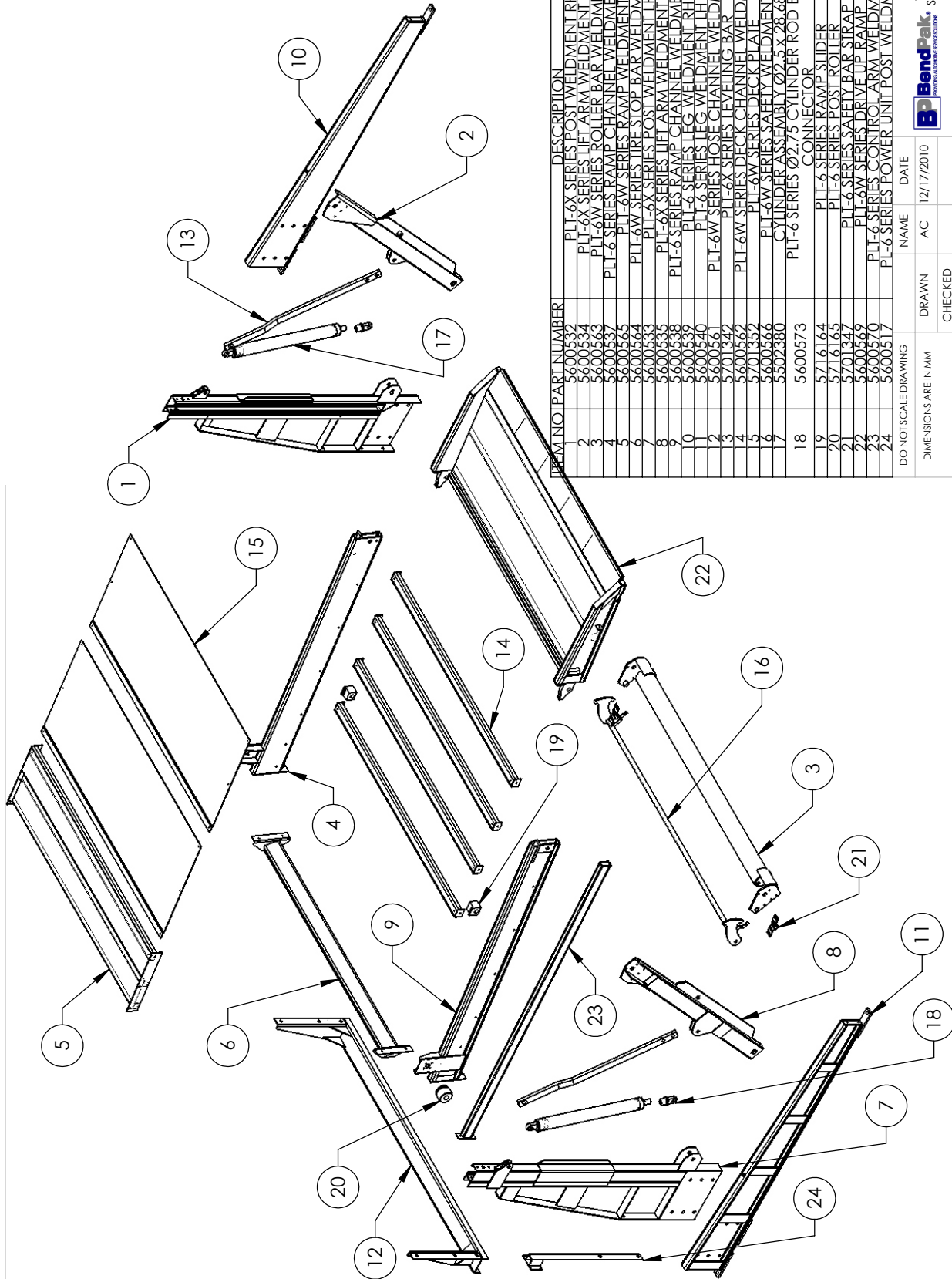

ITEM NO	PART NUMBER	DESCRIPTION	QTY	REV
1	5600532	PLT-6X SERIES POST WELDMENT RH	2	B
2	5600534	PLT-6X SERIES LIFT ARM WELDMENT RH	1	C
3	5600563	PLT-6W SERIES ROLLER BAR WELDMENT	2	B
4	5600537	PLT-6 SERIES RAMP CHANNEL WELDMENT RH	2	B
5	5600545	PLT-6W SERIES RAMP WELDMENT	2	B
6	5600544	PLT-6W SERIES TIRE STOP BAR WELDMENT	2	A
7	5600533	PLT-6X SERIES POST WELDMENT LH	2	B
8	5600535	PLT-6X SERIES LIFT ARM WELDMENT LH	2	C
9	5600538	PLT-6 SERIES ROLLER CHANNEL WELDMENT LH	2	B
10	5600536	PLT-6 SERIES LEG WELDMENT LH	2	B
11	5600540	PLT-6X SERIES HOSE CHANNEL WELDMENT	1	A
12	5600561	PLT-6X SERIES LEVELING BAR	2	A
13	5600562	PLT-6W SERIES DECK CHANNEL WELDMENT	2	B
14	5600562	PLT-6W SERIES DECK CHANNEL WELDMENT	2	B
15	5600566	PLT-6W SERIES SAFETY WELDMENT	1	C
16	5600566	PLT-6W SERIES SAFETY WELDMENT	1	C
17	5502380	CYLINDER ASSEMBLY Ø2.5 X 28.68"	2	C
18	5600573	PLT-6 SERIES Ø2.75 CYLINDER ROD END CONNECTOR	2	B
19	5716164	PLT-6 SERIES RAMP SLIDER	2	B
20	5716165	PLT-6 SERIES POST ROLLER	2	A
21	5701349	PLT-6 SERIES SAFETY BAR STRAP	2	C
22	5600576	PLT-6W SERIES DRIVE UP RAMP	2	C
23	5600576	PLT-6W SERIES DRIVE UP RAMP	2	C
24	5600579	PLT-6 SERIES CONTROL ARM WELDMENT	1	B
24	5600579	PLT-6 SERIES POWER UNIT POST WELDMENT	1	A

DO NOT SCALE DRAWING

NAME: AC DATE: 12/17/2010

DRAWN: AC CHECKED:

THIRD ANGLE PROJECTION

MATERIAL: ---

SIZE: ---

PROPRIETARY AND CONFIDENTIAL
THE INFORMATION CONTAINED IN THIS DRAWING IS THE SOLE PROPERTY OF BENDPAK INC. ANY REPRODUCTION OR TRANSMISSION IN ANY FORM OR BY ANY MEANS WITHOUT THE WRITTEN PERMISSION OF BENDPAK INC. IS PROHIBITED.

1645 LEMONWOOD DR.
BendPak SANTA PAULA, CA 93060

TITLE: PLT-6WX LIFT SUPERSTRUCTURE

SIZE DWG. NO. 5245240

SCALE: 1:40

REV E

SHEET 1 OF 1

NOTE: UNLESS OTHERWISE SPECIFIED, SEE SHIPPING INSTRUCTIONS FOR FINAL PACKAGING

NEXT ASSEMBLY 5260345

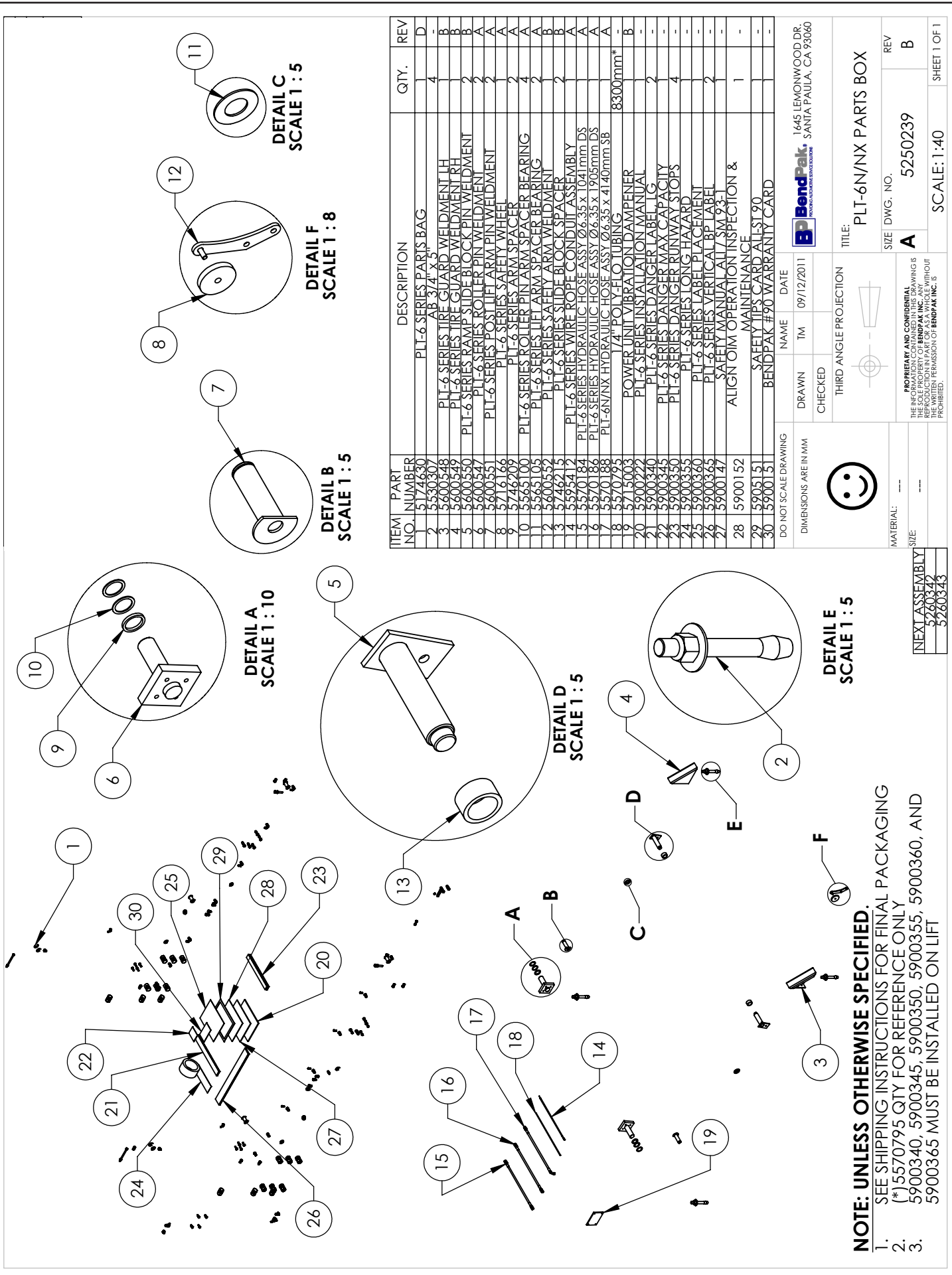

DETAIL C
SCALE 1 : 5

DETAIL F
SCALE 1 : 8

DETAIL B
SCALE 1 : 5

DETAIL A
SCALE 1 : 10

DETAIL D
SCALE 1 : 5

DETAIL E
SCALE 1 : 5

ITEM NO.	PART NUMBER	DESCRIPTION	QTY.	REV
1	574630	PLT-6 SERIES PARTS BAG	1	D
2	5570795	AB 3/4" X 3/8"	4	
3	5900298	PLT-6 SERIES TIRE GUARD WELDMENT LH	1	B
4	5600549	PLT-6 SERIES TIRE GUARD WELDMENT RH	1	B
5	5600550	PLT-6 SERIES RAMP SLIDE BLOCK PIN WELDMENT	2	B
6	5600547	PLT-6 SERIES ROLLER PIN WELDMENT	2	A
7	5600551	PLT-6 SERIES POST LIFT ARM PIN WELDMENT	2	A
8	5716166	PLT-6 SERIES SAFETY WHEEL	2	A
9	5746209	PLT-6 SERIES ARM SPACER	2	A
10	5565100	PLT-6 SERIES ROLLER PIN ARM SPACER BEARING	2	A
11	5665105	PLT-6 SERIES LIFT ARM SPACER BEARING	2	A
12	5600552	PLT-6 SERIES SAFETY ARM WELDMENT	1	B
13	5746215	PLT-6 SERIES STIDE BLOCK SPACER	2	B
14	5795419	PLT-6 SERIES WIRE ROPE CONDUIT ASSEMBLY	2	A
15	5570184	PLT-6 SERIES HYDRAULIC HOSE ASSY 1/4" X 1/4" X 104" DS	2	A
16	5570186	PLT-6 SERIES HYDRAULIC HOSE ASSY 1/2" X 1/2" X 1905mm DS	2	A
17	5570188	PLT-6/NX HYDRAULIC HOSE ASSY 1/2" X 1/2" X 4140mm SB	2	A
18	5570795	1/4" POLY FLO TUBING	8300mm*	A
19	5715003	POWER UNIT VIBRATION DAMPENER	1	B
20	5900222	PLT-6 SERIES INSTALLATION MANUAL	1	-
21	5900340	PLT-6 SERIES DANGER LABEL LG	2	-
22	5900345	PLT-6 SERIES DANGER MAX CAPACITY	2	-
23	5900350	PLT-6 SERIES DANGER RUNWAY STOPS	4	-
24	5900355	PLT-6 SERIES LONG HAZARD	4	-
25	5900370	PLT-6 SERIES LABEL PLACEMENT	1	-
26	5900365	PLT-6 SERIES VERTICAL BP LABEL	2	-
27	5900147	SAFETY MANUAL CALL OUT #93-1	1	-
28	5900152	ALIGN OIM OPERATION INSPECTION & MAINTENANCE	1	-
29	5905151	SAFETY TIPS CARD ALL-ST-90	1	-
30	5900151	BENDPAK #90 WARRANTY CARD	1	-

DO NOT SCALE DRAWING

DIMENSIONS ARE IN MM

DRAWN: TM
DATE: 09/12/2011

CHECKED: _____

THIRD ANGLE PROJECTION

SMILEY FACE

MATERIAL: _____

SIZE: _____

PROPRIETARY AND CONFIDENTIAL
THE INFORMATION CONTAINED HEREIN IS THE PROPERTY OF BENDPAK INC. REPRODUCTION IN PART OR AS A WHOLE WITHOUT PERMISSION OF BENDPAK INC. IS PROHIBITED.

PLT-6/NX PARTS BOX

SIZE DWG. NO. A 5250239

SCALE: 1:40

SHEET 1 OF 1

NOTE: UNLESS OTHERWISE SPECIFIED,

- SEE SHIPPING INSTRUCTIONS FOR FINAL PACKAGING
- (*1)5570795 QTY FOR REFERENCE ONLY
- 5900340, 5900345, 5900350, 5900355, 5900360, AND 5900365 MUST BE INSTALLED ON LIFT

NEXT ASSEMBLY	5260347
	5260348

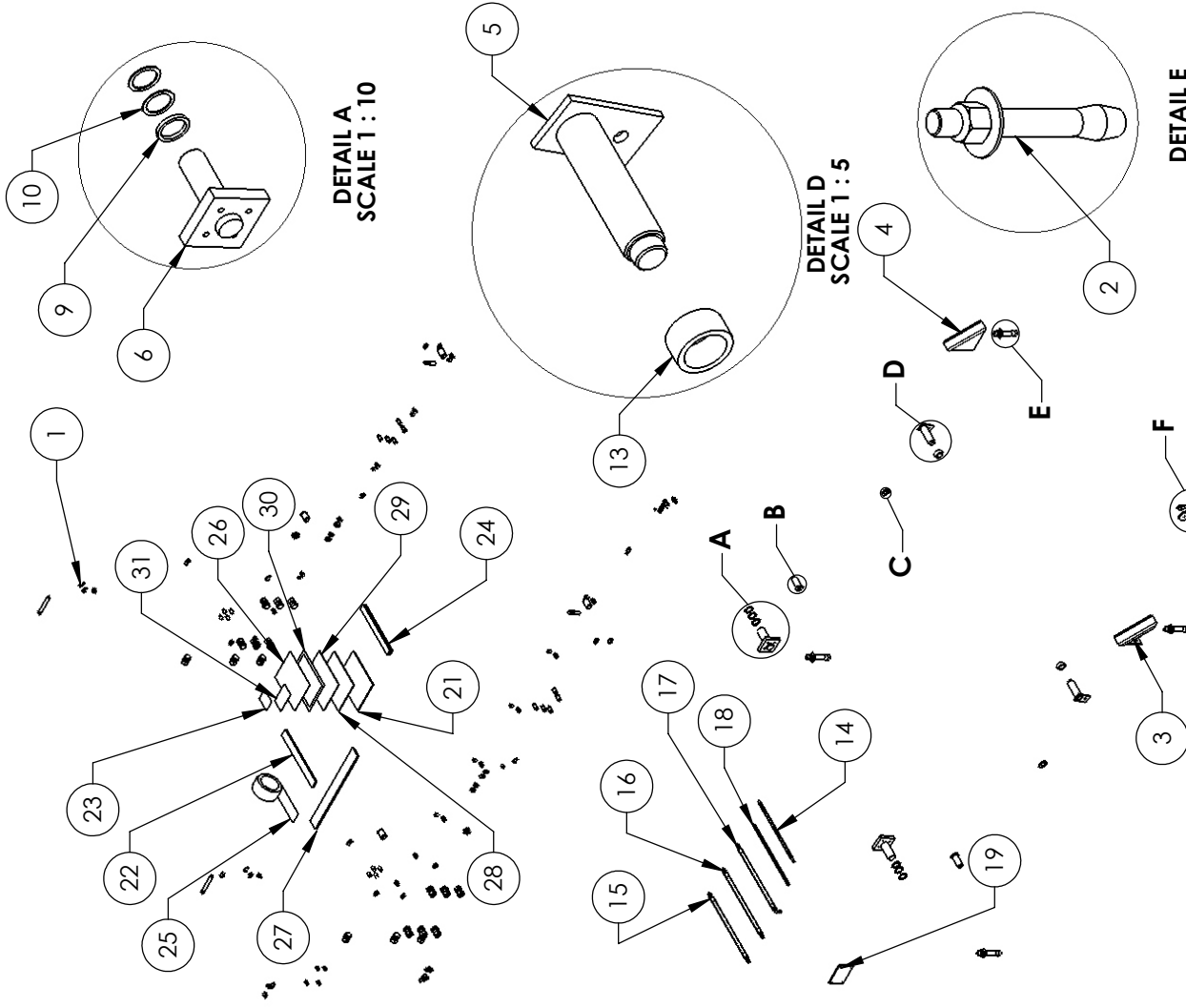

DETAIL C
SCALE 1 : 5

DETAIL F
SCALE 1 : 8

DETAIL B
SCALE 1 : 5

DETAIL A
SCALE 1 : 10

DETAIL D
SCALE 1 : 5

DETAIL E
SCALE 1 : 5

ITEM NO.	PART NUMBER	DESCRIPTION	QTY.	REV
1	5174630	PLT-6 SERIES PARTS BAG	1	D
2	5530307	AB 3/4 X 5	4	B
3	5600548	PLT-6 SERIES TIRE GUARD WELDMENT LH	2	B
4	5600549	PLT-6 SERIES TIRE GUARD WELDMENT RH	2	B
5	5600550	PLT-6 SERIES RAMP SLIDE BLOCK PIN WELDMENT	2	A
6	5600547	PLT-6 SERIES ROLLER PIN WELDMENT	2	A
7	5600551	PLT-6 SERIES POST LIFT ARM PIN WELDMENT	2	A
8	5716166	PLT-6 SERIES SAFETY WHEEL	2	A
9	5746209	PLT-6 SERIES ARM SPACER	2	A
10	5565100	PLT-6 SERIES ROLLER PIN ARM SPACER BEARING	4	A
11	5565105	PLT-6 SERIES LIFT ARM SPACER BEARING	4	A
12	5731728	PLT-6 SERIES SAFETY ARM	2	A
13	5746215	PLT-6 SERIES SLIDE BLOCK SPACER	2	B
14	5554119	PLT-6 SERIES WIRE ROPE END ASSEMBLY	2	A
15	5570184	PLT-6 SERIES HYDRAULIC HOSE ASSY 26.35 X 104.1mm DS	2	A
16	5570186	PLT-6 SERIES HYDRAULIC HOSE ASSY 26.35 X 190.5mm DS	2	A
17	5570187	PLT-6W/WX HYDRAULIC HOSE ASSY 26.35 X 442.0mm SB	2	A
18	5570795	1/4" POLYFLO TUBING	8600mm*	A
19	5715003	POWER UNIT VIBRATION DAMPENER	1	B
20	5530010	HHB M8 X 25 X 25	1	-
21	5900222	PLT-6 SERIES INSTALLATION MANUAL	1	-
22	5900340	PLT-6 SERIES DANGER LABEL LG	2	-
23	5900345	PLT-6 SERIES DANGER MAX CAPACITY	2	-
24	5900350	PLT-6 SERIES DANGER RUNWAY STOPS	4	-
25	5900355	PLT-6 SERIES LONG HAARD	4	-
26	5900360	PLT-6 SERIES LABEL PLACEMENT	1	-
27	5900365	PLT-6 SERIES VERTICAL BP LABEL	2	-
28	5900147	SAFETY MANUAL ATT 7 SM 931	1	-
29	5900152	ALIGN OIM OPERATION INSPECTION & MAINTENANCE	1	-
30	5905151	SAFETY TIPS CARD ATT 90	1	-
31	5900151	BENDPAK #90 WARRANTY CARD	1	-

DO NOT SCALE DRAWING

DIMENSIONS ARE IN MM

DRAWN: TM 09/1/2011

CHECKED:

THIRD ANGLE PROJECTION

TITLE: PLT-6W/WX PARTS BOX

SIZE: DWG. NO. 5250240

REV: C

MATERIAL: ---

SIZE: ---

PROPRIETY AND CONFIDENTIAL
THE SOLE PROPERTY OF BENDPAK INC. ANY
REPRODUCTION IN PART OR AS A WHOLE WITHOUT
PERMISSION OF BENDPAK INC. IS
PROHIBITED.

SCALE: 1:40

SHEET 1 OF 1

- NOTE: UNLESS OTHERWISE SPECIFIED.**
- SEE SHIPPING INSTRUCTIONS FOR FINAL PACKAGING
 - (*) 5570795 QTY FOR REFERENCE ONLY
 - 5900340, 5900345, 5900350, 5900355, 5900360, AND 5900365 MUST BE INSTALLED ON LIFT

NEXT ASSEMBLY	5260344
	5260345

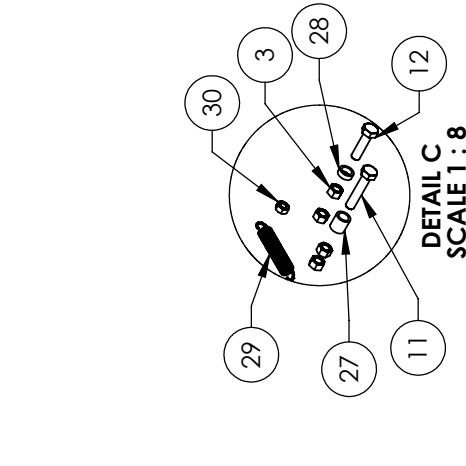

DETAIL C
SCALE 1:8

ITEM NO	PART NUMBER	DESCRIPTION	QTY	REV
1	5530736	HHB M10 X 1.5 X 25	37	---
2	5540775	ERING Ø2.5mm OD DIN.6799.0250	16	---
3	5530013	NUT M10 X 1.5 NL	47	---
4	5530017	NUT M20 X 2.5 NL	18	---
5	5535357	NUT M6 X 1.0 NL	10	---
6	5545341	WASHER M10 X Ø20 FLAT	38	---
7	5530302	HHB M10 X 1.5 X 40	10	---
8	5545026	WASHER M6 X Ø12 SL	18	---
9	5545343	HHB M20 X 2.5 X 45	18	---
10	5530154	HHB M10 X 1.5 X 50	10	---
11	5530759	HHB M10 X 1.5 X 40	10	---
12	5530760	HEX HEAD BOLT M10 X 2.5 X 35	2	---
13	5530113	NUT M12 X 1.75 NL	2	---
14	5530113	HHB M12 X 1.75 X 70	2	---
15	5530318	PLT-6 M6 X 1 X 25MTP	10	---
16	5550106	FIG ELB .04 JIC Ø6 NPT	2	---
17	5746213	PLT-6 SERIES CYLINDER CLEVIS PIN	2	B
18	5746212	PLT-6 SERIES DRIVE UP RAMP PIN	2	B
19	5530213	HHB M10 X 1.5 X 40	2	---
20	5530213	FIG ELB .04 JIC Ø6 ORB	2	---
21	5545200	WASHER M10 X Ø18 SL	3	---
22	5520001	RUBBER GROMMET 3/4 ID	3	---
23	5550004	FIG ELB 1/4 TUBE INS 3/8 NPT	3	---
24	5550489	FIG TEE 1/4-1/4-1/4 TUBE INS	1	---
25	5550181	FIG TEE .04 JIC X .04 NPT	1	---
26	5550153	FIG ELB .04 NPT X .04 JIC	1	---
27	5746210	PLT-6 SERIES SAFETY ROLLER ARM SPACER	1	B
28	5755214	PLT-6 SERIES SAFETY ROLLER ARM SPACER	1	B
29	5540003	SPRING Ø16mm X 90mm	1	A
30	5535001	NUT M8 X 1.25 NL	5	---
31	5746250	PLT-6 SERIES CABLE CONDUIT TERMINAL	2	A
32	5530010	HHB M8 X 1.25 X 25	4	---
33	5746251	PLT-6 SERIES SAFETY BOLT	1	B
34	5535112	NUT M6 X 1.0	2	---
35	5545005	M6 FLAT WASHER	2	---

DO NOT SCALE DRAWING

DRAWN: TM DATE: 12/13/2010

CHECKED: _____

THIRD ANGLE PROJECTION

TITLE: PLT-6 SERIES PARTS BAG

SIZE DWG. NO.: A 5174630

REV: D

MATERIAL: _____

SIZE: _____

SCALE: 1:20

SHEET 1 OF 1

PROPRIETARY AND CONFIDENTIAL
THE BENDPAK SYSTEMS DRAWING IS
THE PROPERTY OF BENDPAK INC.
REPRODUCTION IN PART OR AS A WHOLE WITHOUT
PERMISSION OF BENDPAK INC. IS
PROHIBITED.

1645 LEMONWOOD DR.
SANTA PAULA, CA 93060

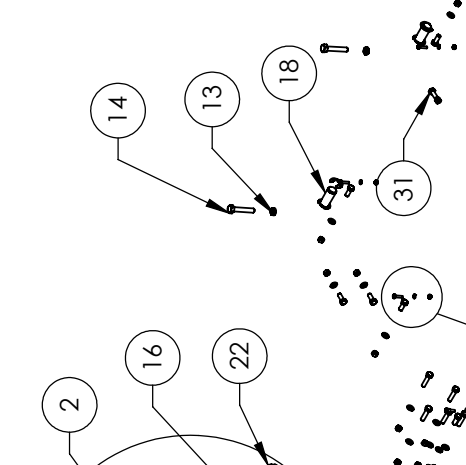

DETAIL A
SCALE 1:12

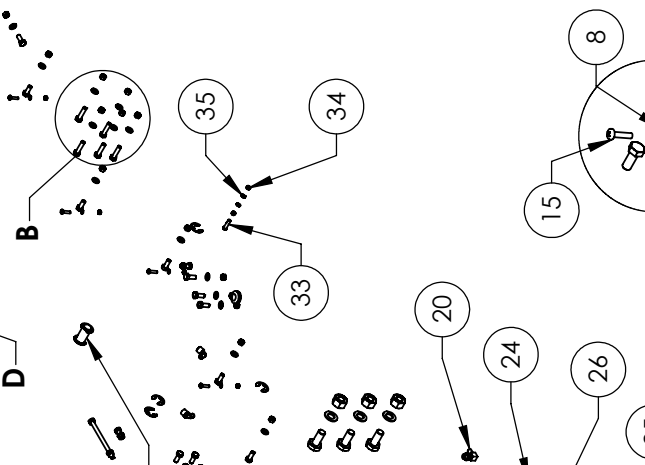

DETAIL D
SCALE 1:8

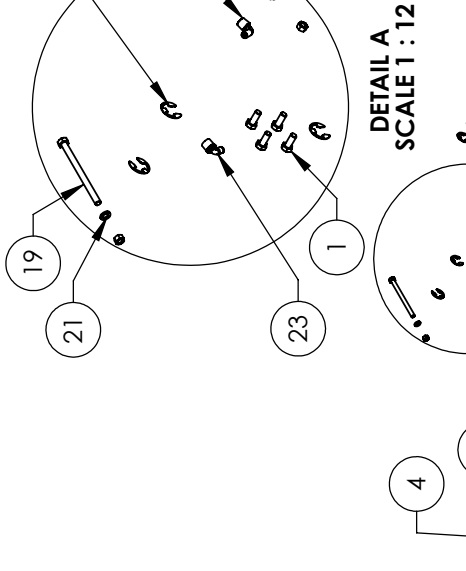

DETAIL B
SCALE 1:6

NEXT ASSEMBLY
5250238
5250239
5250240

NOTE: UNLESS OTHERWISE SPECIFIED,
SEE SHIPPING INSTRUCTIONS FOR FINAL PACKAGING



The best automotive service equipment on the planet.

**For Parts Or Service
Contact:**

**BendPak Inc. / Ranger Products
1645 Lemonwood Dr.
Santa Paula, CA. 93060**

**Tel: 1-805-933-9970
Toll Free: 1-800-253-2363
Fax: 1-805-933-9160**

www.bendpak.com

p/n 5900222

