



ABC10-23120H

Tank Layout	Horizontal
Tank Capacity	120H
Pump Configuration	Two-Stage
Power Supply	230/3
HP	10
CFM @ Max PSI	32
Max PSI	175
Weight	728 lbs.
Length	26.5"
Width	70.1"
Height	49.1"
Warranty	2 Year



KEY FEATURES

- // Magnetic Starter Motor Control
- // Fully Cast Iron Pump
- // Fully Enclosed Belt Guard
- // Discharge Valve

PN: 2020041780



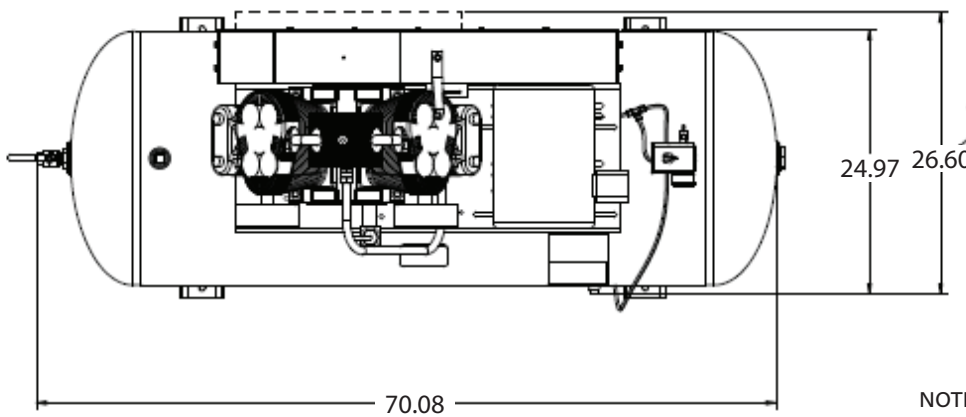
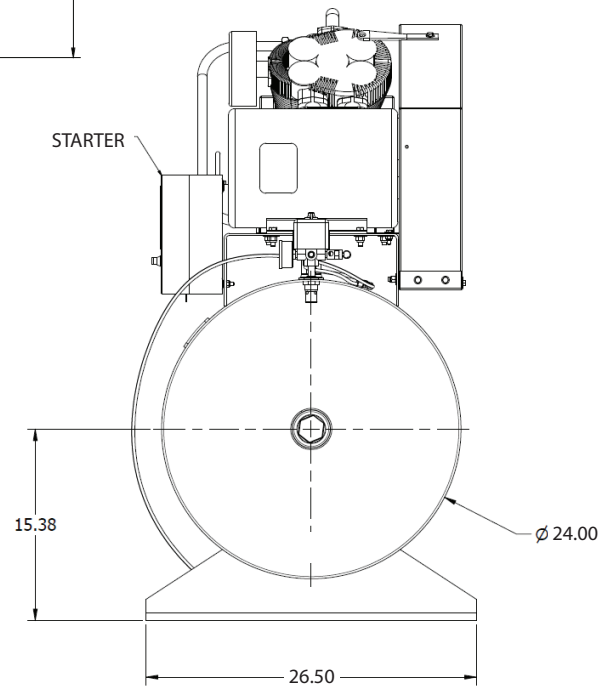
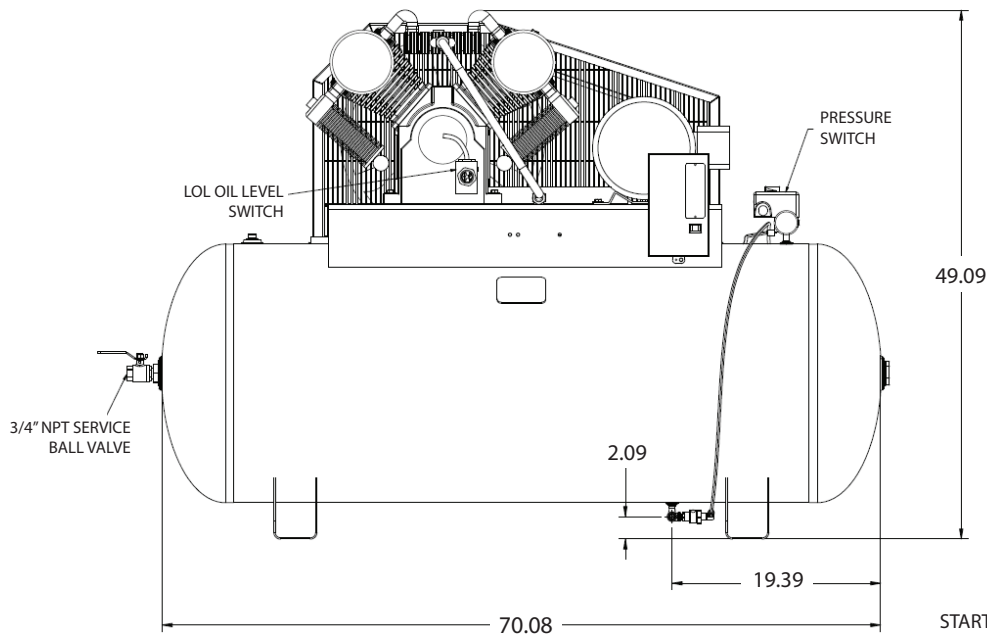

NOTES:

- 1) ALL DIMENSIONS GIVEN IN INCHES
- 2) ALLOW MINIMUM OF 12 INCHES ON ALL SIDES FOR SERVICE AND COOLING