

EVBL3310





Electric Battery Lifting Table



ATLAS Automotive Equipment
www.AtlasAutomotiveEquipment.com
(866) 284-8604

PRINTING CHARACTERS AND SYMBOLS

Throughout this manual, the following symbols and printing characters are used to facilitate reading:

	Indicates the operations which need proper care
	Indicates prohibition
	Indicates a possibility of danger for the operators
BOLD TYPE	Important information

	WARNING: before operating the lift and carrying out any adjustment, read carefully chapter 7 “installation” where all proper operations for a better functioning of the lift are shown.
---	--

CONTENTS

1	GENERAL INFORMATION	4
2	PRODUCT IDENTIFICATION	6
3	PACKING, TRANSPORT AND STORAGE	7
4	PRODUCT DESCRIPTION	8
5	TECHNICAL SPECIFICATION	9
6	SAFETY	15
7	INSTALLATION	18
8	OPERATION AND USE	21
9	MAINTENANCE	24
10	TROUBLESHOOTING	25

CHAPTER 1 – GENERAL INFORMATION

This chapter contains warning instructions to operate the lift properly and prevent injury to operators or objects.

This manual has been written to be used by shop technicians in charge of the lift (operator) and routine maintenance technician (maintenance operator).

The operating instructions are considered to be an integral part of the machine and must remain with it for its whole useful life.

Read every section of this manual carefully before operating the lift and unpacking it since it gives helpful information about:

- SAFETY OF PEOPLE
- SAFETY OF THE LIFT
- SAFETY OF LIFTED BATTERY

The company is not liable for possible problems, damage, accidents, etc. resulting from failure to follow the instructions contained in this manual.

Only skilled technicians of AUTHORISED DEALERS or SERVICE CENTRES AUTHORISED by the manufacturer shall be allowed to carry out lifting, transport, assembling, installation, adjustment, calibration, settings, extraordinary maintenance, repairs, overhauling and dismantling of the lift.

THE MANUFACTURER IS NOT RESPONSIBLE FOR POSSIBLE DAMAGE TO PEOPLE, VEHICLES OR OBJECTS IF SAID OPERATIONS ARE CARRIED OUT BY UNAUTHORIZED PERSONNEL OR THE LIFT IS IMPROPERLY USED.

Any use of the machine made by operators who are not familiar with the instructions and procedures contained herein shall be forbidden.

1.1 MANUAL KEEPING

For a proper use of this manual, the following is recommended:

- Keep the manual near the lift, in an easily accessible place.
- Keep the manual in an area protected from the damp.
- Use this manual properly without damaging it.
- Any use of the machine made by operators who are not familiar with the instructions and procedures contained herein shall be forbidden.

This manual is an integral part of the lift: it shall be given to the new owner if and when the lift is resold.

1.2 OBLIGATION IN CASE OF MALFUNCTION



In case of machine malfunction, follow the instructions contained in the following chapters.

1.3 CAUTIONS FOR THE SAFETY OF THE OPERATOR

Operators must not be under the influence of sedatives, drugs or alcohol when operating the machine.

	Before operating the lift, operators must be familiar with the position and function of all controls, as well as with the machine features shown in the chapter “Operation and use”
---	--

1.4 WARNINGS

	Unauthorized changes and/or modifications to the machine relieve the manufacturer of any liability for possible damages to objects or people. Do not remove or make inoperative the safety devices, this would cause a violation of safety at work laws and regulations.
---	---

	Any other use which differs from that provided for by the manufacturer of the machine is strictly forbidden.
---	---

	The use of non genuine parts may cause damage to people or objects
---	---

1.5 SCRAPPING

When your machine’s working life is over and it can no longer be used, it must be made inoperative by removing any connection to power sources.

These units are considered as special waste material, and should be broken down into uniform parts and disposed of in compliance with current laws and regulations.

If the packing are not polluting or non-biodegradable, deliver them to appropriate handling station.

DECLARATION OF WARRANTY AND LIMITATION OF LIABILITY

The manufacturer has paid proper attention to the preparation of this manual. However, nothing contained herein modifies or alters, in any way, the terms and conditions of manufacturer agreement by which this lift was acquired, nor increase, in any way, manufacturer’s liability to the customer.

TO THE READER

Every effort has been made to ensure that the information contained in this manual is correct, complete and up-to date. The manufacturer is not liable for any mistakes made when drawing up this manual and reserves the right to make any changes due the development of the product, at any time.

CHAPTER 2 – PRODUCT IDENTIFICATION

The identification data of the machine are shown in the label placed on the control unit.

LOGO	
Type:
Model:
Serial Number:
Year of manufacturing:
Capacity:
Voltage:
Power:



Use the above data both to order spare parts and when getting in touch with the manufacturer (inquiry). The removal of this label is strictly forbidden.

Machines may be updated or slightly modified from an aesthetic point of view and, as a consequence, they may present different features from these shown, this without prejudicing what has been described herein.

2.1 WARRANTY CERTIFICATE

The warranty is valid for a period of 12 months starting from the date of the purchase invoice.

The warranty will come immediately to an end when unauthorized modifications to the machine or parts of it are carried out.

The presence of defects in workmanship must be verified by the Manufacturer's personnel in charge.

2.2 TECHNICAL SERVICING

For all servicing and maintenance operations not specified or shown in these instructions, contact your Dealer where the machine has been bought or the Manufacturer's Commercial Department.

Only skilled personnel who are familiar with the lift and this manual shall be allowed to carry out packing, lifting, handling, transport and unpacking operations.

CHAPTER 3 - PACKING, TRANSPORT AND STORAGE

3.1 PACKING

The packing of the lift is delivered in following components:

- N. 1 lifts packed in steel frame
- N. 1 Accessories packed in a carton box

(If requested, optional accessories are available to satisfy each customer's requirements).

The average weight of the package is 720kg.

3.2 LIFTING AND HANDLING

When loading/unloading or transporting the equipment to the site, be sure to use suitable loading (e.g. cranes, trucks) and hoisting means. Be sure also to hoist and transport the components securely so that they cannot drop, taking into consideration the package's size, weight and centre of gravity and its fragile parts.



3.3 STORAGE AND STACKING OF PACKAGES

Packages must be stored in a covered place, out of direct sunlight and in low humidity, at a temperature between 14°F and 104°F.

3.4 DELIVERY AND CHECK OF PACKAGES

When the lift is delivered, check for possible damages due to transport and storage; verify that what is specified in the manufacturer's confirmation of order is included. In case of damage in transit, the customer must immediately inform the carrier of the problem.

Packages must be opened paying attention not to cause damage to people (keep a safe distance when opening straps) and parts of the lift (be careful the objects do not drop from the package when opening).

CHAPTER 4 - PRODUCT DESCRIPTION

LIFT DESCRIPTION (Ref. Figure 1)

The lift has been designed for the lifting of battery or engine of electric vehicles for maintenance.

The maximum lifting weight is as specified on the serial plate.

All mechanical frames, such as platforms, base frames and arms have been built in steel plate to make the frame stiff and strong while keeping a low weight.

The electro hydraulic operation is described in detail in chapter 8.

This chapter describes the lift's principal elements, allowing the user to be familiar with the machine. As shown in figure 1, the lift is composed of two tables, scissor arms, base frame and mobile jack. The top table (1) is supported by the bottom table (2), which is linked to the base frame (3) by means of a scissor lifting system.

The top table can be tilted in left/right and front/rear direction automatically by the linear actuator (4) operated by the remote control (5). It can be extended out by releasing the locking screw (6).

The bottom table lowering and lifting are carried out by operation of the remote control which is driven by the hydraulic cylinder (7) operated by control unit (8). It can be manually moved from side to side by handle (9) when all of the locks (10) are released.

The mobile jack (11) is fixed in front of base frame to move the lift.

The safety lock(12) is added to prevent suddenly fall down.

Figure 1 – LIFT

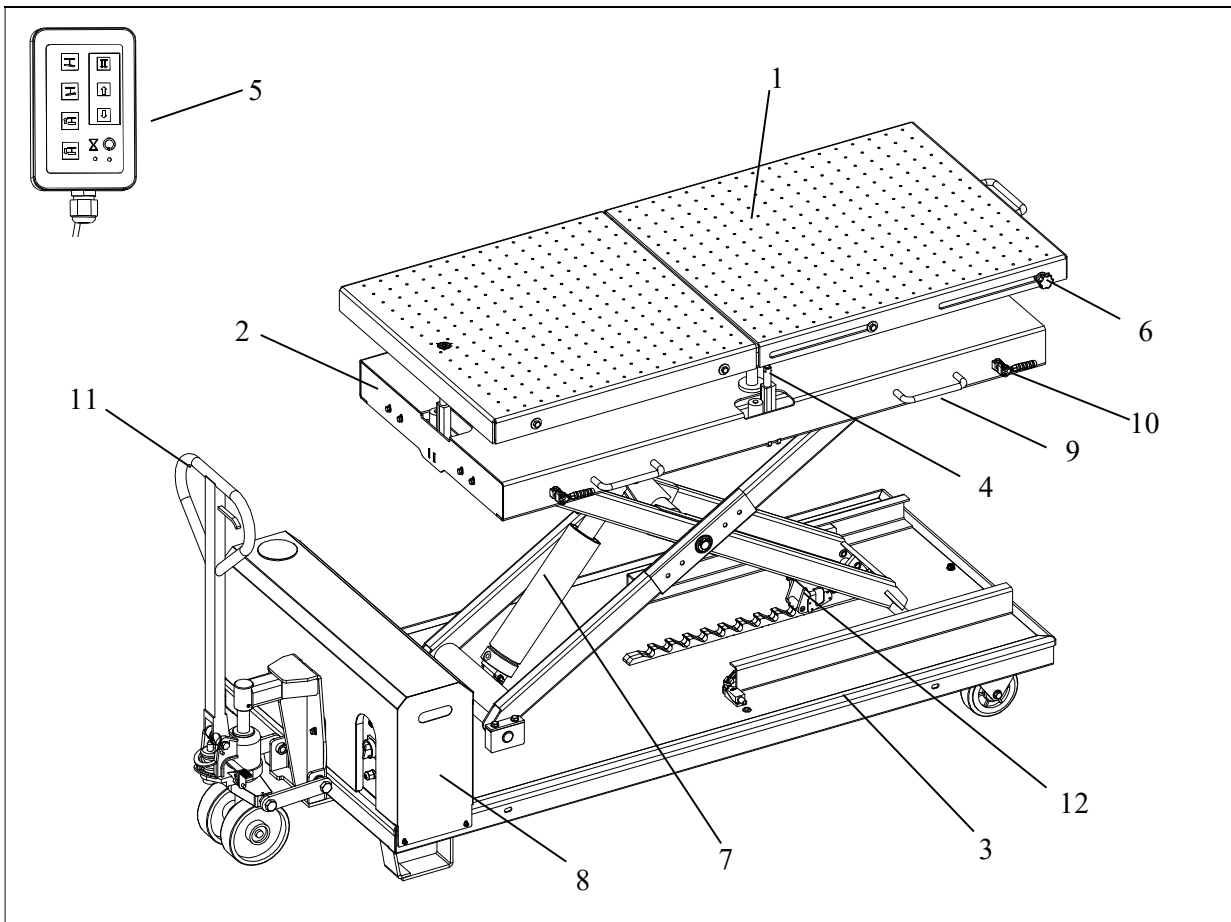

CHAPTER 5 - TECHNICAL SPECIFICATION

5.1 SIZE AND MAIN FEATURES (Ref. Figure 2)

CAPACITY	3,310 lbs (1500KG)
Max. lifting height	71 in (1810mm)
Min. lift height	29 in (738mm)
Length of the platform	68-79.75 in (1728 - 2026mm)
Width of platform	32 in (810mm)
Tilting angle in left/right side	+/- 5.1°
Tilting angle in front/rear side	+/- 2.2°
Lifting time	29 s
Lowering time	27 s
Noise level	80 dB(A)/1m
Working temperature	14 °F - 104 °F
Average weight of package	1590 lbs (720 kg)

5.2 ELECTRIC MOTOR

Type	ML90L4-B14	MS90L4-B14
Voltage	110V/230V/220V-1Ph	400V/380V-3Ph
Power	1.5 KW	
N° Poles	4	4
Speed	1375 rpm	1375 rpm
Insulation class	IP 54	

Motor connection must be carried out referring to the attached wiring diagrams (the figure. 5).

The motor direction of rotation is shown in the label placed on the motor.

Before use of the lift, make sure to check if the motor specification shown in the nameplate of the motor conforms to the local electric supply.

If there is over 10% fluctuation on the electrical power supply, it is suggested to use the voltage stabilizer to protect the electrical components and system from overloading.

5.3 PUMP

Type	Gear
Flow rate	2.1 cm ³ /g
Continuous working pressure	190 bar

Figure 2 - LAYOUT

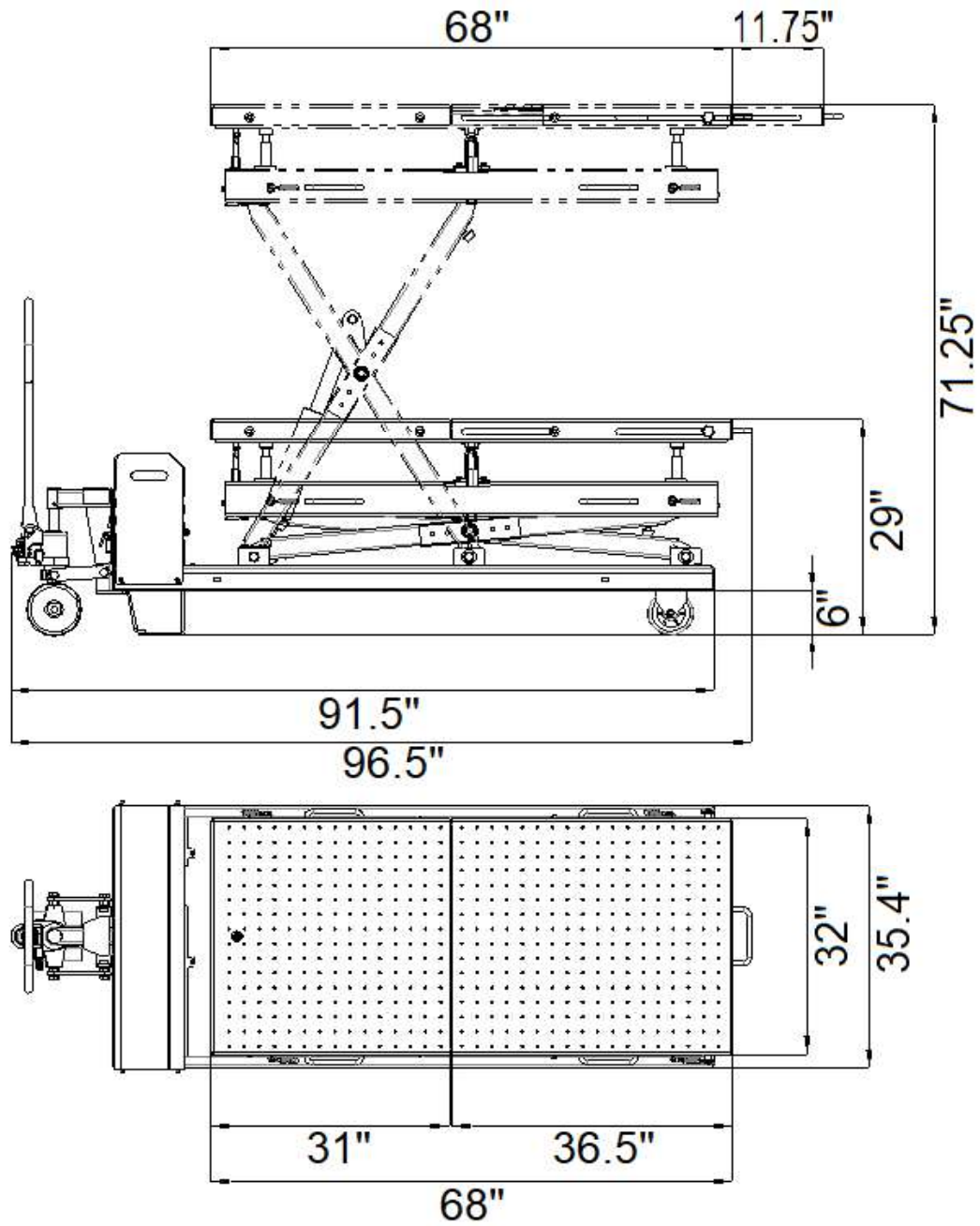

5.4 HYDRUALIC POWER UNIT

The following hydraulic power unit (Fig.3) can be found by removing the mobile jack (Fig.1-10) and the cover (Fig.1-7).

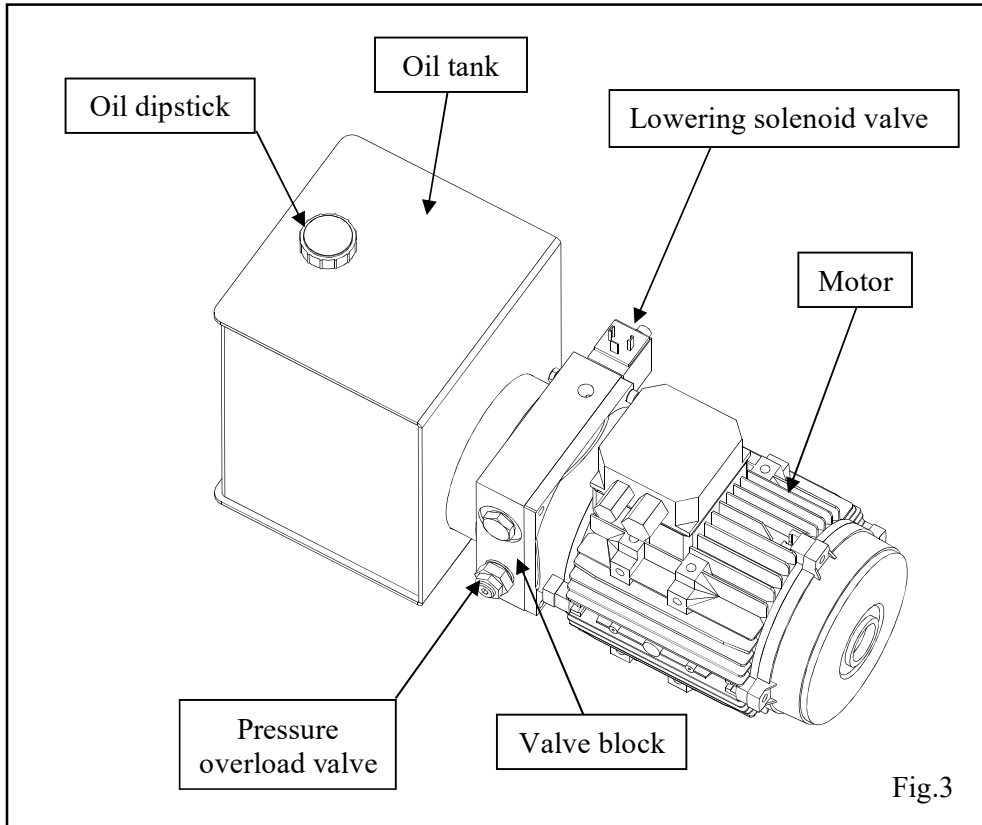

Fig.3

5.5 OIL

Use wear proof oil for hydraulic drive, in conformity with *ISO 6743/4* rules (HM class). The oil with features similar to those shown in the table is recommended.

TEST STANDARDS	FEATURES	VALUE
ASTM D 1298	Density 20°C	0.8 kg/l
ASTM D 445	Viscosity 40°C	32 cSt
ASTM D 445	Viscosity 100°C	5.43 cSt
ASTM D 2270	Viscosity index	104 N°
ASTM D 97	Pour point	~ 30 °C
ASTM D 92	Flash point	215 °C
ASTM D 644	Neutralization number	0.5 mg KOH/g

	CHANGE HYDRAULIC OIL AT 1 YEAR INTERVALS
---	---

Figure 4 – HYDRAULIC PLAN

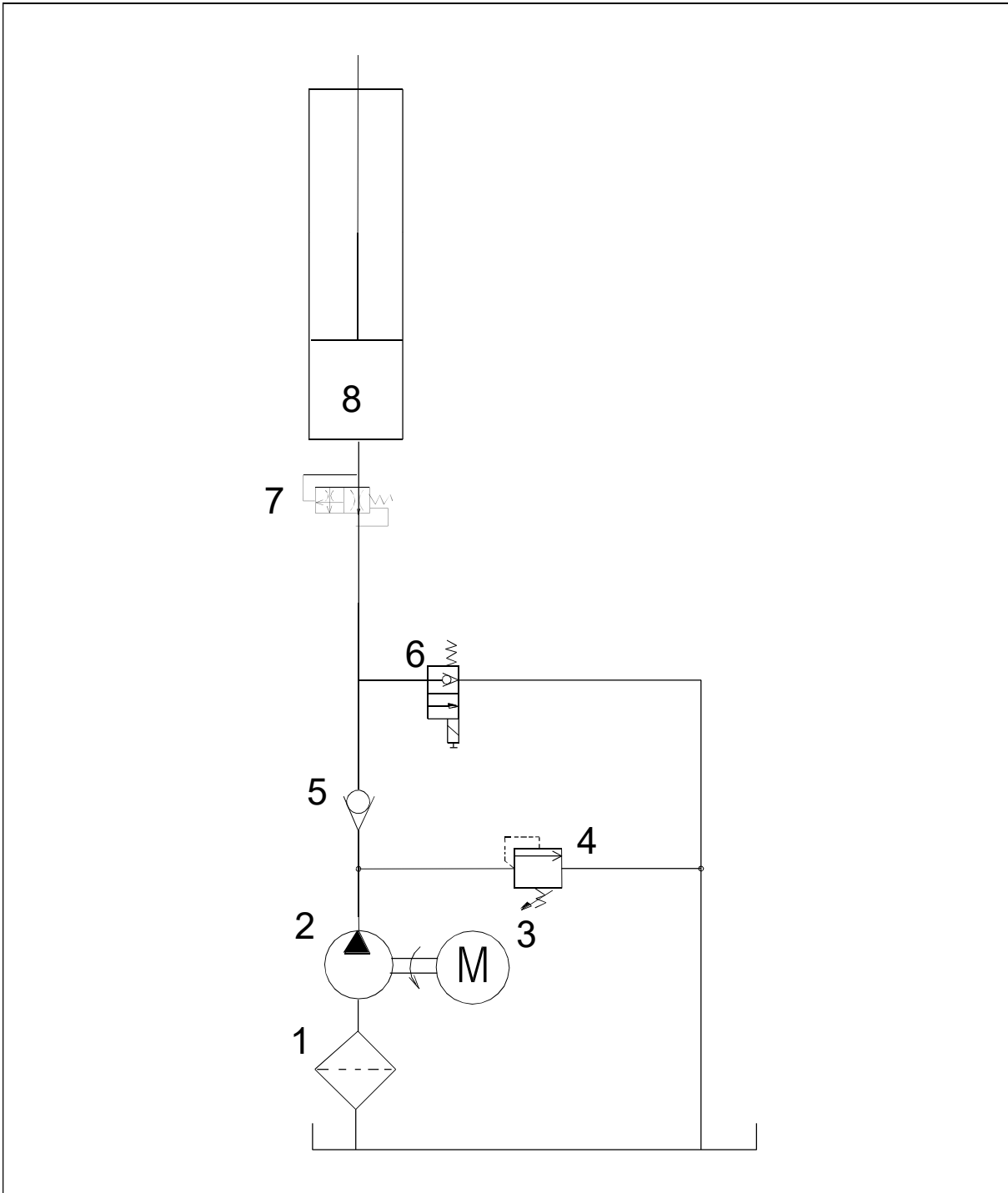

1	Oil filter	5	Non return valve
2	Gear pump	6	Lowering solenoid valve
3	Motor	7	Speed control valve
4	Pressure overload valve	8	Hydraulic cylinders

Figure 5a – ELECTRICAL WIRING DIAGRAM (400V/380V-3PH)

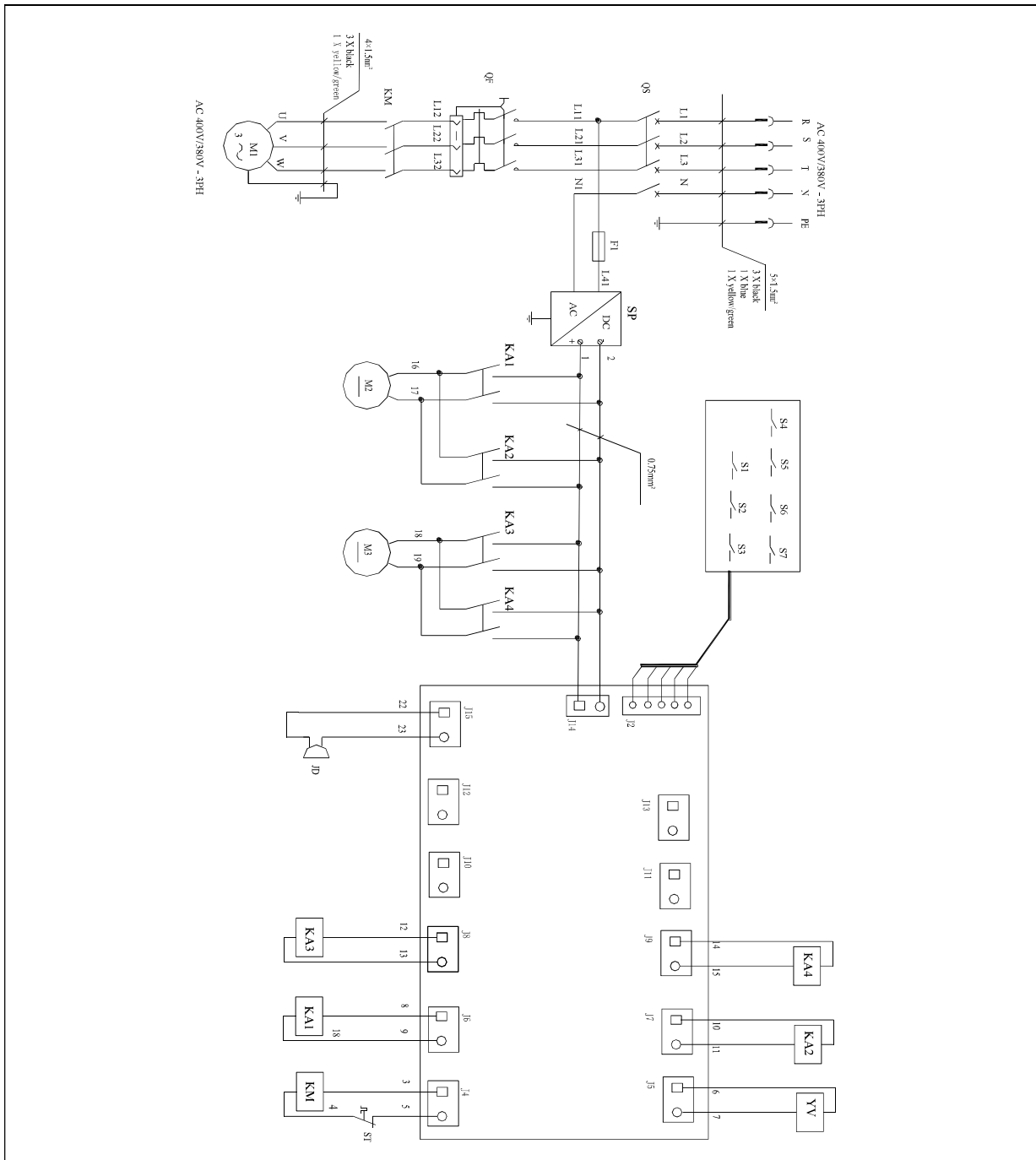

QS	Power switch	KA1/KA3	Relay
QF	Breaker	KA2/KA4	Relay
M1	Motor 1.5KW	SB1	Lifting button
M2/M3	Linear actuator	SB2	Lowering button
ST	Thermal relay	SB3	Not available for this model
SP	Switch power	SB4	Tilting forward button
KM	Contactor AC	SB5	Tilting backward button
YV	Lowering solenoid valve	SB6	Tilting leftward button
JD	Beeper	SB7	Tilting rightward button

Figure 5b – ELECTRICAL WIRING DIAGRAM (230V/220V-1PH)

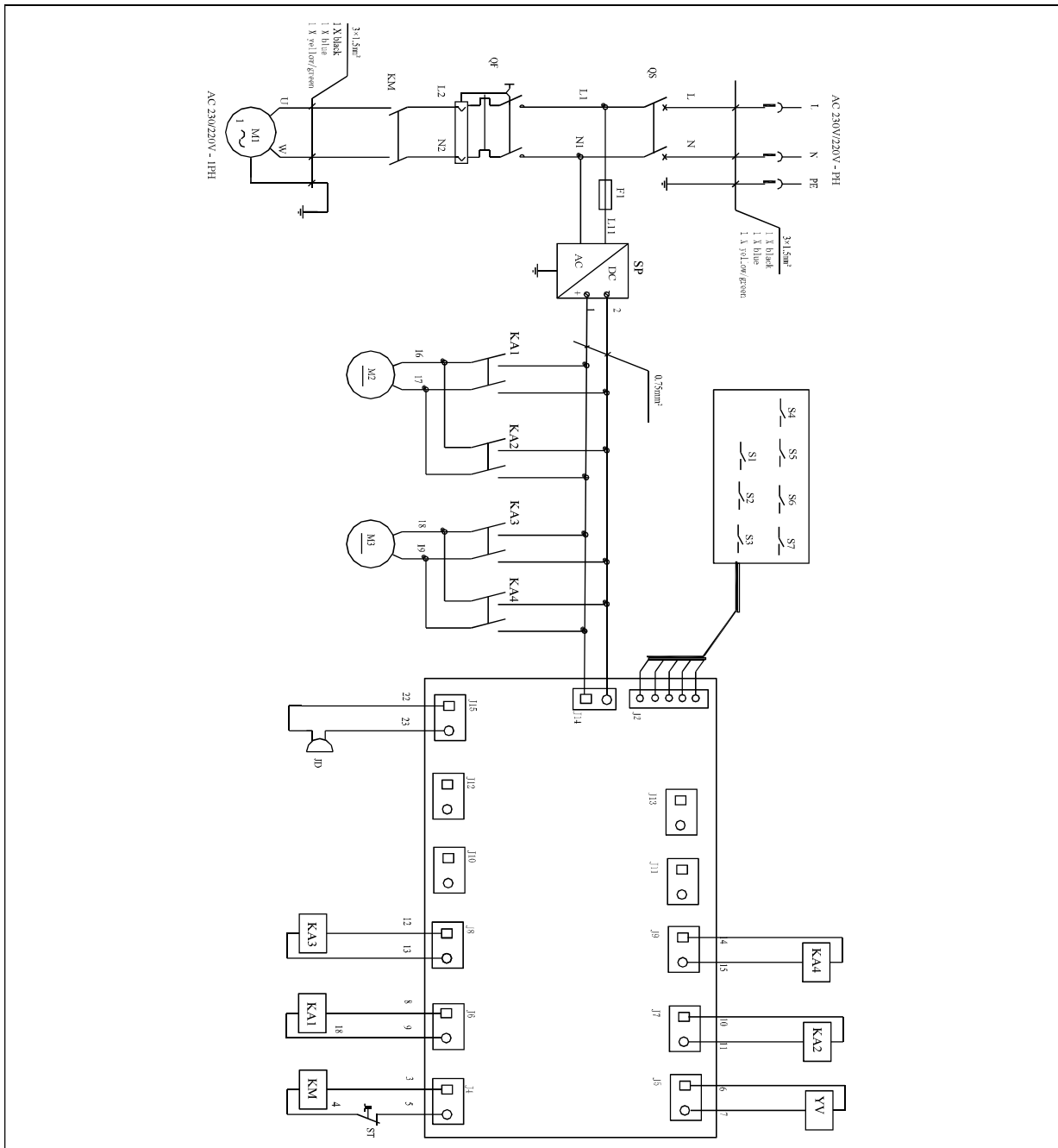

QS	Power switch	KA1/KA3	Relay
QF	Breaker	KA2/KA4	Relay
M1	Motor 1.5KW	SB1	Lifting button
M2/M3	Linear actuator	SB2	Lowering button
ST	Thermal relay	SB3	Not available for this model
SP	Switch power	SB4	Tilting forward button
KM	Contactor AC	SB5	Tilting backward button
YV	Lowering solenoid valve	SB6	Tilting leftward button
JD	Beeper	SB7	Tilting rightward button

CHAPTER 6 – SAFETY

Read this chapter carefully and completely because it contains important information for the safety of the operator and the person in charge of maintenance.

	<p>The lift has been designed and built for lifting vehicles and making them stand above level in a closed area. Any other use is forbidden.</p> <p>The manufacturer is not liable for possible damages to people, vehicles or objects resulting from an improper or unauthorized use of the lift.</p>
---	--

For operator and people safety, a safety area at least 1m free away from the lift must be vacated during lifting and lowering. The lift must be operated only from the operator's control site in this safety area. Operator's presence under the vehicle, during working, is only admitted when the vehicle is lifted and platforms are not running.

	<p>Never use the lift when safety devices are off-line. People, the lift and the vehicles lifted can be seriously damaged if these instructions are not followed.</p>
---	--

6.1 GENERAL WARNINGS

The operator and the person in charge of maintenance must follow accident-prevention laws and rules in force in the country where the lift is installed

They also must carry out the following:

- neither remove nor disconnect hydraulic, electric or other safety devices;
- carefully follow the safety indications applied on the machine and included in the manual;
- observe the safety area during lifting;
- be sure the motor of the vehicle is off, the gear engaged and the parking brake put on;
- be sure only authorized vehicles are lifted without exceeding the maximum lifting capacity;
- Verify that no one is on the platforms during lifting or standing.

6.2 RISKS DURING VEHICLE LIFTING

To avoid overloading and possible breaking, the following safety devices have been used:

- a maximum pressure valve placed inside the hydraulic unit to prevent excessive weight.
- A special design of the hydraulic system, in case of pipeline failure, to prevent sudden lift lowering..

	<p>The maximum pressure valve has been preset by the manufacturer to a proper pressure. DO NOT try to adjust it to overrun the rated lifting capacity.</p>
---	---

6.3 RISKS FOR PEOPLE

All risks the personnel could run, due to an improper use of the lift, are described in this section.

6.4 PERSONNEL CRUSHING RISKS

During lowering the lift, personnel must not be within the area covered by the lowering trajectory. The operator must be sure no one is in danger before operating the lift.



Fig. 7a



Fig. 7b



Fig. 7c

6.5 BUMPING RISK

When the lift is stopped at relatively low height for working, the risk of bumping against projecting parts occurs.



Fig. 8

6.6 RISK OF THE OBJECT FALLING FROM THE LIFT

Object 是 falling from the lift can be caused when the vehicle is improperly placed on platforms, and when its dimensions are incompatible with the lift or by excessive movement of the vehicle. In this case, keep immediately away from the working area.



Fig. 9a



Fig. 9b

6.7 SLIPPING RISKS

The risk of slipping can be caused by oil or dirt on the floor near the lift.



Fig. 10



Keep the area under and around the lift clean. Remove all oil spills.

6.8 ELECTROCUTION RISKS

Avoid use of water, steam, and solvent, varnish jets in the lift area where electric cables are placed and, in particular, next to the electric panel.

6.9 RISKS RESULTING FROM IMPROPER LIGHTING

Make sure all areas next to the lift are well and uniformly lit, according to local regulations.

6.10 RISKS OF BREAKING COMPONENT DURING OPERATION

Materials and procedures, suitable for the designed parameters of the lift, have been used by the manufacturer to build a safe and reliable product. Operate the lift only for the use it has been designed for and follow the maintenance schedule shown in the chapter “Maintenance”.



Fig. 11

6.11 RISKS FOR UNAUTHORIZED USES

The presence of unauthorized persons next to the lift and on the table is strictly forbidden during lifting as well as when the load has been already lifted

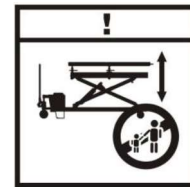

Fig. 12



Any use of the lift other than that herein specified can cause serious accidents to people in close proximity of the machine.

CHAPTER 7 – INSTALLATION

	<p>Only skilled technicians, appointed by the manufacturer, or by authorized dealers, must be allowed to carry out installation. Serious damage to people and to the lift can be caused if installations are made by unskilled personnel.</p>
---	--

7.1 CHECKING FOR PLACE SUITABILITY

The lift has been designed to be used in covered and sheltered places free of overhead obstructions. The working place must not be next to washing areas, painting workbenches, solvent or varnish deposits. The relevant standards of the local Health and Safety at Work regulations, for instance, with respect to minimum distance to wall or other equipment, escapes and the like, must be observed. All areas next to the lift must be well and uniformly lit.

7.2 CONCRETE SURFACE

The lift must be placed on the concrete surface sufficiently resistant. The surface must be suitable for bearing maximum stress values, also in unfavorable working conditions. The surface must be perfectly leveled.

7.3 HYDRAULIC SYSTEM CONNECTION

- Connecting hydraulic hoses referring to Fig. 13 is made by the manufacturer;
- Check if all of the fittings are tightened thoroughly.

Figure 13 – HYDRAULIC CONNECTION

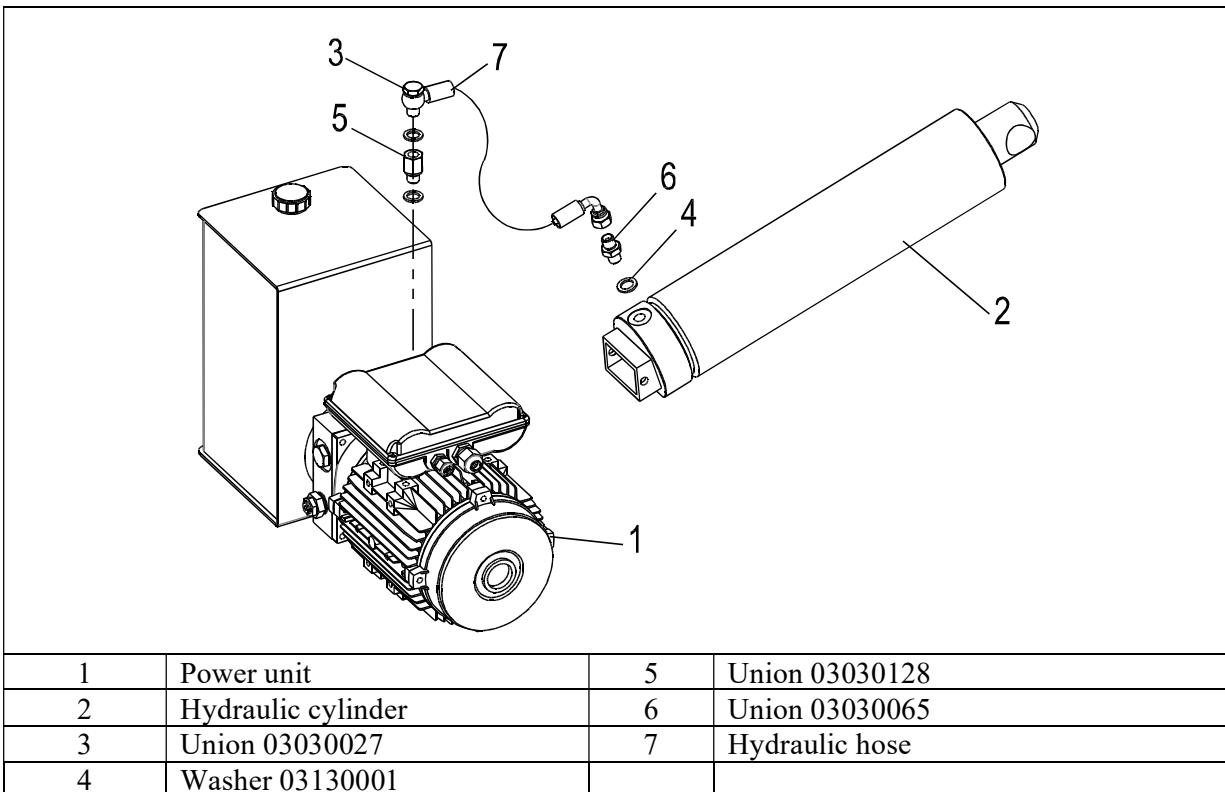

7.4 MAKE THE ELECTRICAL HOOKUP TO HYDRAULIC POWER UNIT

	<p>The hookup work must be carried out by a qualified electrician.</p> <p>Make sure that the power supply is right.</p> <p>Make sure the connection of the phases is right. Improper electrical hook-up can damage motor and will not be covered under warranty.</p> <p>DO NOT run the hydraulic unit with no oil. Damage to pump can occur.</p> <p>The power unit must be kept dry.</p>
---	---

- Make the electric hookup to the power unit referring to the attached the electric diagram fig.5 using the included electric cable.
- Make sure the connection of the phases is right and lift is grounded.

7.5 START

	<p>During this procedure, DO NOT attempt to raise the lift with any load.</p>
---	--

- Make sure all pins and bolts to insure proper mounting
- Make sure the electrical system feeding voltage is equal to that specified in the nameplate on the motor
- Make sure the electric connections are in compliant with diagrams Fig. 5
- Make sure no leakage or blow-up in hydraulic line
- Make sure the working area is free from people and objects
- Grease sliding seats of blocks placed under platforms and on bases
- Pour oil in the tank (*about 6 liters more than one time*)
- Verify that the control unit is powered
- Verify that the motor direction of rotation is that shown on the label by pushing the lifting button. **IF MOTOR GETS HOT OR SOUNDS PECULIAR, STOP IMMEDIATELY AND RECHECK THE ELECTRIC CONNECTIONS**
- Raising the lift slowly by pressing the lifting button until cylinders bottom out and the lift stops. **DO NOT** continue pressing button after lift reaches full height. Damage to motor can occur if continued.
- Repeat raise and lower the lift completely at least 3 times to remove the air from the hydraulic system completely.

7.6 INSTALLATION THE HANDLE

- Use the supplied M8X20 screws and D.8 washers to fix the handle in front of top table according to Fig.14.

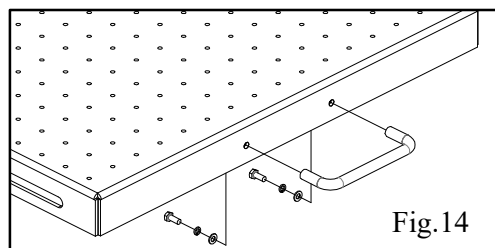

7.7 INSTALLATION OF MOBILE JACK

- Use the supplied M8X30 screws and D.8 washers to fix the main jack (Fig.15-1) to the support welded on the base frame according to Fig.15.
- Install the jack handle (Fig.15-2) on the main jack by the supplied shaft and cotter pin.

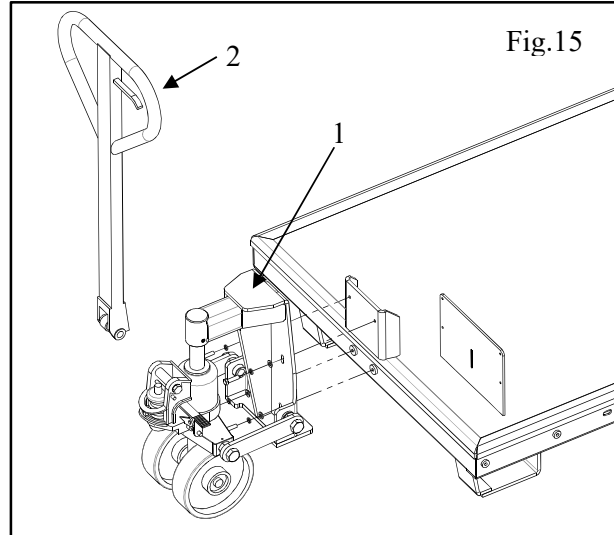

7.8 CHECKS LESS LOAD

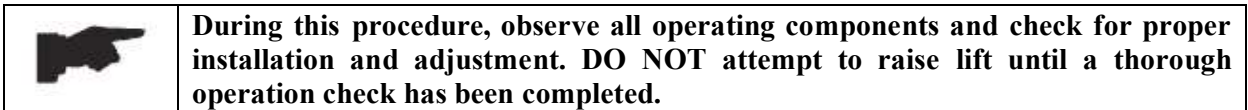

Carry out two or three complete cycles of lowering and lifting and check:

- the safety devices for proper operation
- proper oil level in the tank
- no leakage and blow-by in hydraulic line
- cylinder for proper operation
- the horn/signaling light for proper operation during the lowering travel

7.9 CHECKING WITH LOAD

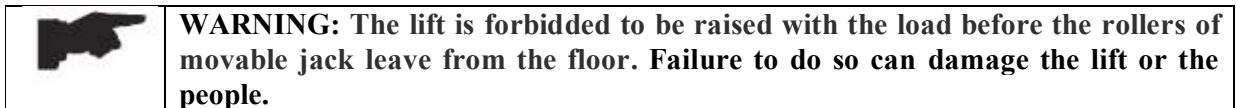

Carry out two or three complete cycles of lowering and lifting and check:

- Repeat the 7.8 section
- Check no strange noise during lifting and lowering

CHAPTER 8 - OPERATION AND USE

	<p>Never operate the lift with any person or equipment below.</p> <p>Never exceed the rate lifting capacity.</p> <p>Do not permit the electric control unit to get wet!</p>
---	--

8.1 CONTROLS

CONTROL PANEL (Figure 16)

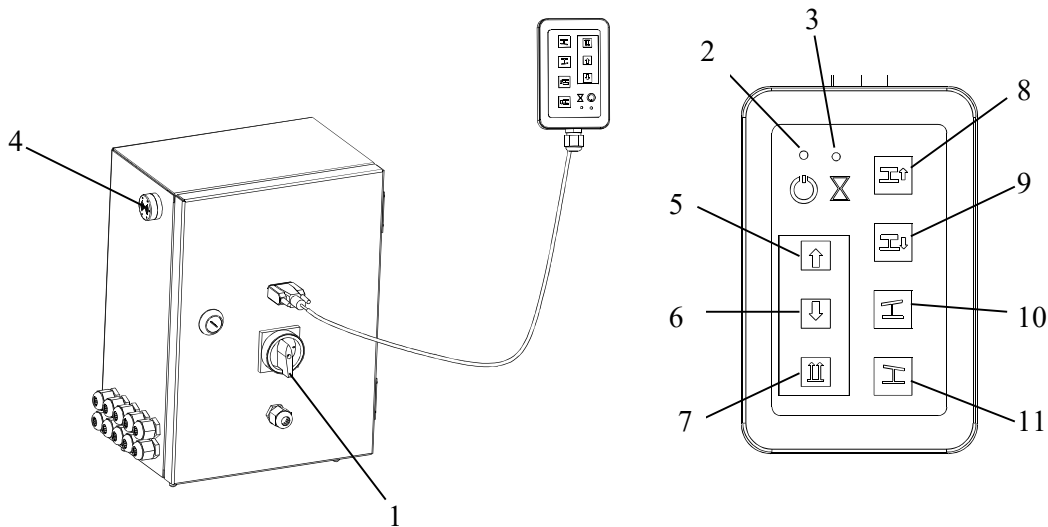

Controls for operating the lift are:

POWER SWITCH (1)

The switch can be set in two positions:

- **0 position:** the lift electric circuit is not powered; the switch can be padlocked to prevent the use of the lift.
- **1 position:** the main electric circuit is powered.

PILOT LAMP FOR POWER SWITCH (2)

PILOT LAMP FOR REMOTE CONTROL (3)

BEEPER (4)

LIFTING BUTTON (5)

- When pressed, the electric circuit for the lift operates the motor and hydraulic circuit to raise the lift.

LOWERING BUTTON (6)

- When pressed, the lift begins to descend under its weight and the load lifted, in the meantime the beeper is activated and the sound can be heard.

SPEED UP BUTTON (7): NOT AVAILABLE FOR THIS MACHINE

TILTING FORWARD BUTTON (8)

- When pressed, the top table is tilted forward.

TILTING BACKWARD BUTTON (9)

- When pressed, the top table is tilted backward.

TILTING LEFTWARD BUTTON (10)

- When pressed, the top table is tilted leftward.

TILTING RIGHTWARD BUTTON (10)

- When pressed, the top table is tilted rightward.

8.2 TO RAISE THE LIFT



It is extremely forbidden to load the battery when the mobile jack wheels still support the base frame. Failure to do so can cause the danger

- Position the lift just under the battery.
- Press the lifting button to raise the top table until it almost touches the battery, then adjust the top table by pressing the corresponding button (Fig.16-8,9,10 or 11) so that the battery could be placed on the table horizontally.
- Press the lifting button until the battery could be supported by the top platform completely.
- If the battery has been demounted from the car, check to be sure the battery is secured tightly on the top table.



Failure to do so could make the battery slip out of the top table to cause serious damage.

8.3 TO LOWER THE LIFT

- Be sure the safety area is free of people and objects;
- Press the lowering button to lower the lift;

8.4 TO MOVE THE LIFT

- *Make sure to lower the lift completely before moving the lift.*
- Check to be sure the mobile jack is connected to the lift tightly;
- Before moving, check to make sure to provide an accessible exit.
- Raise the lift by mobile jack until the base support (Fig.17-1) leaves from the floor.
- Move the lift to the required place under the help of the rollers (Fig.17-2) fixed on the base frame.

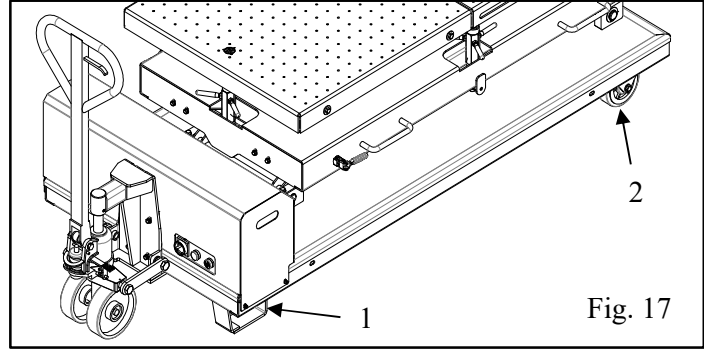

To move the lift with the raised load could cause serious damage.

CHAPTER 9 - MAINTENANCE

	Only trained personnel who knows how the lift works, must be allowed to service the lift.
---	--

To service properly the lift, the following has to be carried out:

- use only genuine spare parts as well as equipment suitable for the work required;
- follow the scheduled maintenance and check periods shown in the manual;
- discover the reason for possible failures such as too much noise, overheating, oil blow-by, etc.

Refer to documents supplied by the dealer to carry out maintenance:

- functional drawing of the electric and hydraulic equipment
- exploded views with all data necessary for spare parts ordering
- list of possible faults and relevant solutions.

	Before carrying out any maintenance or repair on the lift, disconnect the power supply, padlock the general switch and keep the key in a safe place to prevent unauthorized persons from switching on or operating the lift.
---	---

9.1 ORDINARY MAINTENANCE

The lift has to be properly cleaned at least once a month using self-cleaning clothes. Lubricate all pivot pins at least once a week.

	The use of water or inflammable liquid is strictly forbidden.
---	--

Be sure the rod of the hydraulic cylinders is always clean and not damaged since this may result in leakage from seals and, as a consequence, in possible malfunctions.

9.2 PERIODIC MAINTENANCE

Every 3 months	Hydraulic circuit	<ul style="list-style-type: none"> ▪ check oil tank level; refill with oil, if needed; ▪ check the circuit for oil leakage. ▪ check seals for proper conditions and replace them, if necessary;
	Hydraulic pump	<ul style="list-style-type: none"> ▪ verify that no noise changes take place in the pump when running and check fixing bolts for proper tightening
	Safety system	<ul style="list-style-type: none"> ▪ check safety devices for proper operation
Every 6 months	Oil	<ul style="list-style-type: none"> ▪ check oil for contamination or ageing. Contaminated oil is the main reason for failure of valves and shorter life of gear pumps.
Every 12 months	General check	<ul style="list-style-type: none"> ▪ verify that all components and mechanisms are not damaged
	Electrical system	<ul style="list-style-type: none"> ▪ a check of the electrical system to verify that motor and control panel operate properly must be carried out by skilled electricians
	Oil	<ul style="list-style-type: none"> ▪ empty the oil tank and change the hydraulic oil

CHAPTER 10 – TROUBLESHOOTING

A list of possible troubles and solutions is given below

TROUBLE:	POSSIBLE CAUSE:	SOLUTION:
The lift does not work	The main switch is not turned on	Turn the switch on
	There is no power	Check Power on to restore if necessary
	The electrical wires are disconnected	Reconnect
	Fuses are blown	Replace
The lift does not raise	The motor direction of rotation is not correct.	Interchange the two phases on the main switch
	The oil in the hydraulic unit is not sufficient.	Add some hydraulic oil
	Presences of air in the hydraulic circuit	Bleed the hydraulic system
	The UP button is faulty.	Check UP button and connection for proper operation. Replace, if needed
	The maximum pressure valve is faulty	Check and clean if dirty or replace if needed
	The lowering solenoid valve does not close.	Check and clean if dirty or replace if faulty
	The pump filter is dirty.	Check and clean if needed.
	The pump suction is blown	Check the seal and replace if needed
The lift does not lower when the DOWN button is pressed	The lowering solenoid valve does not work properly	Verify if it is powered and check magneto for damage (replace if disconnected or blown).
	The DOWN button is faulty	Check and replace if needed
The lift does not lift or lower smoothly	Leakages or presences of air into hydraulic circuit	Bleed the hydraulic system
	The pump filter is dirty.	Check and clean if needed.
	The pump suction is blown	Check the seal and replace if needed
Top table is not adjusted	Linear actuator does not work	Verify if it is powered and check to replace if needed
	Button is faulty	Check and replace if needed