

## Swing Arm Tire Changer Installation and Operation Manual

Manual P/N 5900408 — Manual Revision A2 — December 2024

### Models:

- R980DP
- R980DP-L

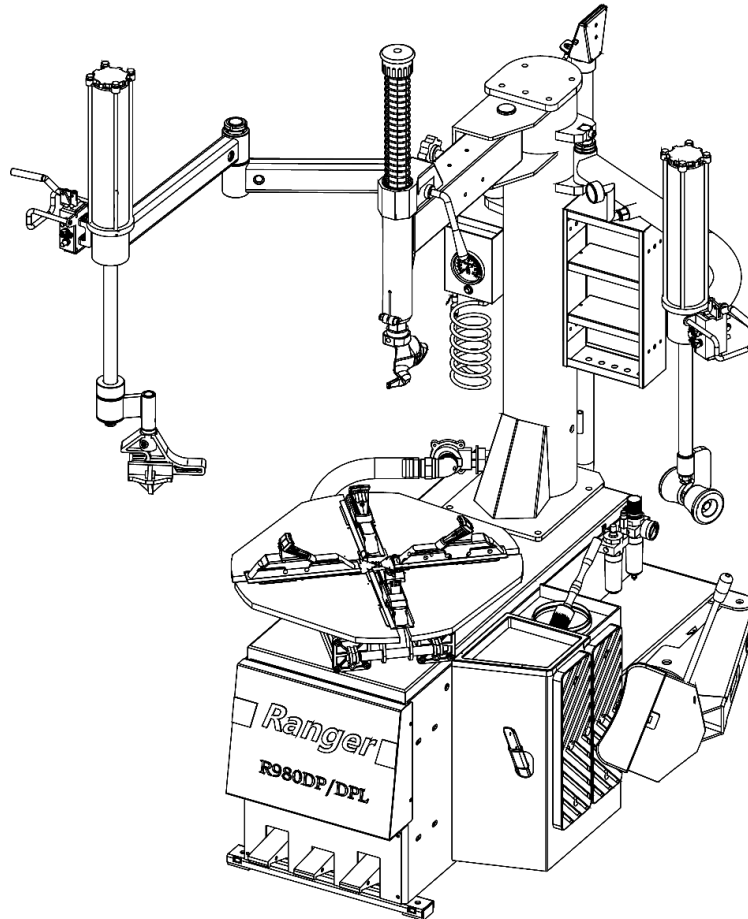

Designed and engineered in Southern California, USA. Made in China.



## DANGER

**IMPORTANT SAFETY INSTRUCTIONS, SAVE THESE INSTRUCTIONS! Read the entire contents** of this manual *before* using this product. Failure to follow the instructions and safety precautions in this manual can result in serious injury or death. Make sure all other operators also read this manual. Keep the manual near the product for future reference. **By proceeding with setup and operation, you agree that you fully understand the contents of this manual and assume full responsibility for product use.**

**Manual.** R980DP and R980DP-L Swing Arm Tire Changer, *Installation and Operation Manual*, P/N 5900408, Revision A2, Released December 2024.

**Copyright.** © 2024 by BendPak, Inc. All rights reserved. You may make copies of this document if you agree that: you will give full attribution to BendPak Inc., you will not make changes to the content, you do not gain any rights to this content, and you will not use the copies for commercial purposes.

**Trademarks.** BendPak, the BendPak logo, Ranger, and the Ranger logo are registered trademarks of BendPak Inc. All other company, product, and service names are used for identification only. All trademarks and registered trademarks mentioned in this manual are the property of their respective owners.

**Limitations.** Every effort has been made to have complete and accurate instructions in this manual. However, product updates, revisions, and/or changes may have occurred since this manual was published. BendPak Ranger reserves the right to change any information in this manual without incurring any obligation for equipment previously or subsequently sold. BendPak Ranger is not responsible for typographical errors in this manual. You can always find the latest version of the **manual for your product on the Ranger website**.



SCAN FOR  
DIGITAL PDF

**Warranty.** The BendPak Ranger warranty is more than a commitment to you: it is also a commitment to the value of your new product. For full warranty details, contact your nearest BendPak Ranger dealer or visit **[bendpak.com/support/warranty](https://bendpak.com/support/warranty)**.

**Safety.** Your new product was designed and manufactured with safety in mind. Your safety also depends on proper training and thoughtful operation. Do not set up, operate, maintain, or repair the unit without reading and understanding this manual and the labels on it; **do not use this product unless you can do so safely!**

**Owner Responsibility.** In order to maintain your product properly and to ensure operator safety, it is the responsibility of the product owner **to read and follow these instructions**:

- Follow all installation, operation, and maintenance instructions.
  - Make sure product installation and operation conforms to all applicable local, state, and federal codes, rules, and regulations, such as state and federal OSHA regulations and electrical codes.
  - Read and follow all safety instructions. Keep them readily available for operators.
  - Make sure all operators are properly trained, know how to safely operate the unit, and are properly supervised.
  - Do not operate the product until you are certain that all parts are in place and operating correctly.
  - Carefully inspect the product on a regular basis and perform all maintenance as required.
  - Service and maintain the unit only with approved replacement parts.
  - Keep the manual with the product and make sure all labels are clean and visible.
- **Only use this product if it can be used safely!**

**Unit Information.** Enter the Model Number, Serial Number, and the Date of Manufacture from the label on your unit. This information is required for part or warranty issues.

Model: \_\_\_\_\_

Serial: \_\_\_\_\_

Date of Manufacture: \_\_\_\_\_

---

# Table of Contents

<b>Introduction</b> .....	<b>3</b>	<b>Operation</b> .....	<b>22</b>
<b>Shipping Information</b> .....	<b>4</b>	<b>Maintenance</b> .....	<b>51</b>
<b>Safety Considerations</b> .....	<b>4</b>	<b>Troubleshooting</b> .....	<b>54</b>
<b>Components</b> .....	<b>6</b>	<b>Wiring Information</b> .....	<b>55</b>
<b>FAQ</b> .....	<b>8</b>	<b>Labels</b> .....	<b>56</b>
<b>Specifications</b> .....	<b>9</b>	<b>Parts</b> .....	<b>60</b>
<b>Installation Checklist</b> .....	<b>10</b>	<b>Maintenance Log</b> .....	<b>79</b>
<b>Installation</b> .....	<b>11</b>		

## Introduction

This manual describes the following tire changer models:

- **R980DP.** 3 HP, 220 VAC, Tire Changer with Dual power-assist traveling mount and demount arms.
- **R980DP-L.** 2 HP, 110 VAC, Tire Changer with Dual power-assist traveling mount and demount arms.

More information about BendPak Ranger products is available at the [BendPak Ranger website](#).

***This manual is mandatory reading for all users*** of the R980DP Series of Tire Changers, including anyone who sets up, operates, maintains, or repairs them.

You can always find the latest version of the [manual for your product on the BendPak Ranger website](#).

**⚠ DANGER** Practice SAFETY when operating, maintaining, or repairing this equipment; failure to do so could result in property damage, product damage, injury, or (in very rare cases) death. Make sure only authorized personnel operate this equipment. All repairs must be performed by an authorized technician. Do not make modifications to the unit; this voids the warranty and increases the chances of injury or property damage. Make sure to read and follow the instructions on the labels on the unit.

Keep this manual on or near the equipment so that anyone who uses or services it can read it.

Technical support and service for your Tire Changer is available from your distributor or by calling **BendPak Ranger at (805) 933-9970** then follow the prompts. You may also call regarding parts replacement (please have the serial number and model number of your unit available).

---

# Shipping Information

Your equipment was carefully checked before shipping. Nevertheless, you should thoroughly inspect the shipment **before** you sign to acknowledge that you received it.

When you sign the bill of lading, it tells the carrier that the items on the invoice were received in good condition. **Do not sign the bill of lading until after you have inspected the shipment.** If any of the items listed on the bill of lading are missing or damaged, do not accept the shipment until the carrier makes a notation on the bill of lading that lists the missing or damaged goods.

If you discover missing or damaged goods **after** you receive the shipment and have signed the bill of lading, notify the carrier at once and request the carrier to make an inspection. If the carrier will not make an inspection, prepare a signed statement to the effect that you have notified the carrier (on a specific date) and that the carrier has failed to comply with your request.

It is difficult to collect for loss or damage after you have given the carrier a signed bill of lading. If this happens to you, file a claim with the carrier promptly. Support your claim with copies of the bill of lading, freight bill, invoice, and photographs, if available. Our willingness to assist in helping you process your claim does not make us responsible for collection of claims or replacement of lost or damaged materials.

# Safety Considerations

**Read this manual carefully before using your new product.** Do not set up or operate the product until you are familiar with all operating instructions and warnings. Do not allow anyone else to operate the product until they are also familiar with all operating instructions and warnings.

 **WARNING California Proposition 65.** This product can expose you to chemicals including styrene and vinyl chloride which are on the list of over 900 chemicals identified by the State of California to cause cancer, birth defects or reproductive harm. **ALWAYS** use this product in accordance with BendPak's instructions. For more information go to [www.P65Warnings.ca.gov](http://www.P65Warnings.ca.gov).

 **WARNING** There are many moving parts on a Tire Changer; keep clear of these moving parts and the Tire being changed. In particular, when inflating a Tire, never lean over the Tire; if it were to explode (which does happen), the force could injure or kill the Operator or bystanders. During inflation, the Operator should be as far away from the Tire as possible, and all bystanders must be at least 30 feet away.

## Safety Information

Please note the following:

- The product is a Tire Changer. **Use it only for its intended purpose.**
- The product **must** only be operated by authorized, trained, properly supervised personnel. Keep children and untrained personnel at least 30 feet away from the product when it is in use.
- Always follow all applicable local, state, and federal codes, rules, and regulations, including (but not limited to) OSHA standard 1910.177 (Servicing multi-piece and single piece rim wheels).

- You **must** wear OSHA-approved (publication 3151) personal protective equipment at all times when installing, using, maintaining, or repairing the Tire Changer: leather gloves, steel-toed work boots, eye protection, back belts, and hearing protection **are mandatory**.
- Keep hair, loose clothing, jewelry, fingers, and all body parts away from moving parts. Avoid pinch points.
- Unplug the unit when not in use, if not hard wired into the electrical system.
- Do not use the product while tired or under the influence of drugs, alcohol, or medication.
- Do not use the product in the presence of cigarette smoke, dust, or flammable liquids or gases. Use the product indoors in a well-ventilated area.
- Do not make any modifications to the product; this voids the warranty and increases the chances of injury or property damage. **Do not modify any safety-related features in any way**.
- Make sure all Operators read and understand this *Installation and Operation Manual*. Keep the Manual near the device at all times.
- Make a visual inspection of the product every day. Do not use the product if you find any missing or damaged parts. Instead, take the unit out of service, then contact an authorized repair facility, your distributor, or **BendPak Ranger at (805) 933-9970**, then follow the prompts.
- BendPak Ranger recommends making a **thorough** inspection of the product once a month. Replace any damaged or severely worn parts, decals, or warning labels.

## Symbols

Following are the symbols that may be used in this manual:



**DANGER**

Calls attention to a hazard that **will** result in death or injury.



**WARNING**

Calls attention to a hazard or unsafe practice that **could** result in death or injury.



**CAUTION**

Calls attention to a hazard or unsafe practice that could result in personal injury, product damage, or property damage.

**NOTICE**

Calls attention to a situation that, if not avoided, could result in product or property damage.



**Tip**

Calls attention to information that can help you use your product better.

## Liability Information

BendPak Ranger assumes **no** liability for damages resulting from:

- Use of the equipment for purposes other than those described in this manual.
- Modifications to the equipment without prior written permission from BendPak Ranger.
- Injury or death caused by modifying, disabling, overriding, or removing safety features.
- Damage to the equipment from external influences.
- Incorrect operation of the equipment.

# Components

Image identifies the main components of the Tire Changer. Descriptions on the following page.

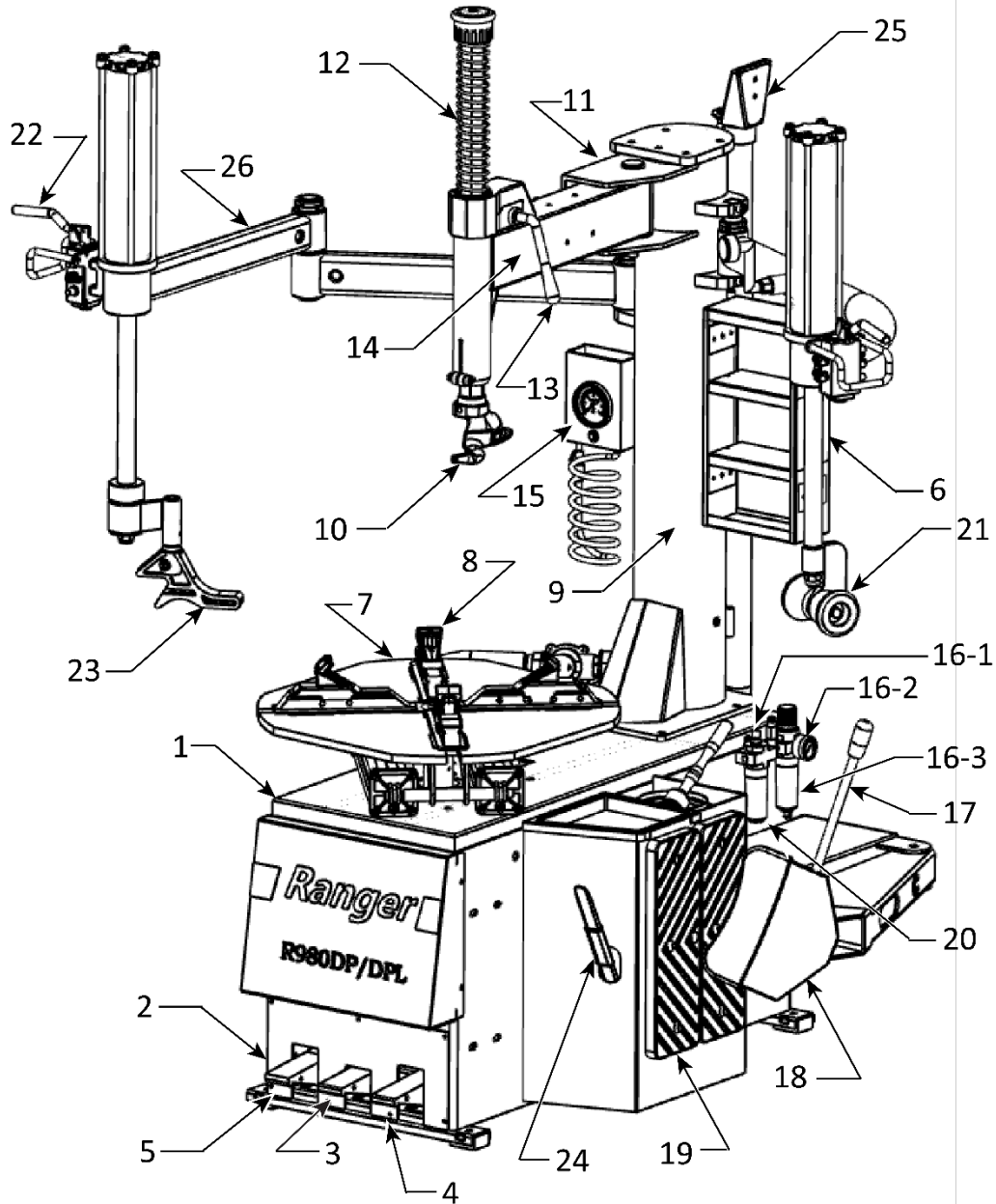

*R980DP shown; Not all components visible.*

---

### **Tire Changer components include:**

1. The Machine Case is the main part of the machine.
2. Inflation Pedal is located on the side of panel, (not visible in graphic).
3. Pedal Controls turntable clamping.
4. Pedal Controls operation of the bead breaking shovel.
5. Pedal Controls the rotation of the working plate.
6. Storage Cabinet holds common tools.
7. The Turntable rotates the rim.
8. RimGuard™ Wheel Clamps protects the rim.
9. Main Tower air tank supports tire demounting and mounting arms.
10. Mount/Demount Head (Duck Head) works as a tire removal tool.
11. Locking Twist Knob (not visible in graphic) limits the horizontal arm's movement.
12. Shaft holds the demounting head.
13. Shaft Lock handle locks the hexagonal shaft
14. Horizontal arm swings the horizontal arm away.
15. Inflation Gauge displays tire pressure.
- 16-1. Regulator/Filter and Oiler/Lubricator adjusts the air pressure.
- 16-2. Regulator/Filter and Oiler/Lubricator separates moisture from the air.
- 16-3. Regulator/Filter and Oiler/Lubricator supplies oil to the air.
17. Bead Breaking Arm supports the bead breaking shovel.
18. Bead Breaker separates tire from the rim.
19. Tire Rubber Pad supports the rim.
20. Nameplate Serial number (not visible).
21. Tire Press Roller assists in tire mounting.
22. Helper Arm Control valve allows the press block to rise and fall.
23. Assist Tool presses the tire's sidewall down.
24. Bead Lifting Tool leverages the tire on or off the rim.
25. Turbo-Blast™ Bead Sealer seats the tire bead.
26. Swing Arm allows Assist Tool to be positioned.

Tire Changer accessories include:

- **Lube Bucket.** For your Tire lubricant. Only use a lubricant approved by the Tire manufacturer for the Tire being changed.
- **Lube Brush.** To spread your Tire lubricant.
- **Extra Air Line Parts.** Provided in case they are needed in the future.
- **Extra Yellow Plastic Pieces.** Provided in case they are needed in the future.

---

# Frequently Asked Questions

**Question:** What does a Tire Changer accomplish?

**Answer:** A Tire Changer removes Tires off of Wheels (termed Demounting) and installs Tires onto Wheels (termed Mounting).

**Q:** What are the definitions of a Tire, Wheel, and Rim?

**A:** The Wheel is the round **metal** component that attaches to the Vehicle's axle. The Tire is the round **rubber** pneumatic component that surrounds the Wheel. The outer edge of the Wheel, where the Tire seals to the Wheel, is the Rim. Sometimes Wheel and Rim are used interchangeably.

**Q:** What are the steps in the process of demounting a Tire and then mounting a new Tire?

**A:** The steps are: Deflate the Tire, break the Bead, secure the Wheel on the Turntable, demount the Tire, mount the new Tire, inflate the new Tire, then remove the Wheel from the Turntable.

**Q:** Breaking the bead.

**A:** A Tire is held on the Rim of a Wheel by the Tire Bead set between the Rim Lip and the Bead Retainer of the Rim. The air pressure in the Tire holds it in place once the Bead is seated (during mounting). When you "break the Bead", you move the Tire Bead out of the location where it was seated, which is required to take the Tire off of the Wheel.

**Q:** Can I break the Bead without fully deflating the Tire?

**A:** No, **Always fully deflate a Tire before attempting to break its Bead**. The air pressure energy in a Tire, even if not fully inflated, can be considerable. If you were to attempt to break the Bead of a Tire not fully deflated, that air pressure energy would be released all at once, possibly injuring or, in rare cases, killing the Operator or bystanders.

**Q:** Rim and tire size when working with the Tire Changer?

**A:** You must match Rim Width with the Tire you are mounting. The result of a mismatch is that the Tire could explode off the Wheel when you inflate it or while the Vehicle is being driven. In both cases, people could be injured or killed.

**Q:** Placing the Tire Changer?

**A:** On a flat Concrete floor with room around it that is also near where you work on Tires. Ideally, you want it a little off the beaten path, as you must – for safety – keep everyone away from the Tire Changer while it is in use. No one other than the Operator should be within 30 feet of the Tire Changer while it is in use.

**Q:** Why isn't there a plug on the end of the Power Cord?

**A:** 220 VAC plugs vary by region, so when using a Power Cord with Plug, use a Plug that is appropriate for the power outlet you will be using. The other power option is to wire the Tire Changer directly into the facility's power system. You **must have** a licensed Electrician perform all electrical work in accordance with all applicable electrical codes.

110 VAC units are prewired with a cord and plug.



# Specifications

<b>Model</b>	<b>R980DP</b>	<b>R980DP-L</b>
Motor	R980DP: 208-240VAC 14.2/13.1Amps, 50/60Hz. 1 Ph 3HP	R980DP-L: 110VAC, 18 Amps, 50/60 Hz., 1 Ph, 2HP
Drive System Type	Electric / Air	
Air Requirement	110 – 175 psi at 15-25cfm (8 – 12 bar at 0.4-0.7cmm)	
Wheel Clamping	4 Clamps – Internal / External	
Table Clamping	Dual Pneumatic Cylinders	
Bead Breaking	Pneumatic Blade	
Tower Design	Rigid Fixed / Swing Arm	
Assist Tower	Double Assist Tower (standard)	
Bead Sealing	Turbo Blast and Inflation Gauge	
Internal Rim Clamping	9 – 30 in. (254 – 762 mm)	
External Rim Clamping	9 – 26 in. (229 – 660 mm)	
Turntable Tire Width Capacity (Mounting)	4 – 15 in. (102 – 381 mm)	
Bead Breaker Tire Width Capacity (Demounting)	1.5 – 13 in. (38 – 330 mm)	
Maximum Tire Diameter	50 in. (1,270 mm)	
Sound	<70 dB	
Length	47.25 in. (1,200 mm)	
Width	60.25 in. (1,530 mm)	
Height	82.25 in. (2,090 mm)	

**Specifications subject to change without notice.**

---

# Installation Checklist

Following are the steps needed to install the Tire Changer. Perform them in the order shown.

- 1. Review the installation Safety Rules.
- 2. Make sure you have the necessary Tools.
- 3. Find an appropriate Location.
- 4. Make sure there is adequate Clearance around and above.
- 5. Unpack the Unit.
- 6. Install the Swing Arm Tower, Turbo Blast, Bead Breaker and make air connections.
- 7. Install the Toolbox and Inflation Gauge.
- 8. Install the Assist Tower
- 9. Remove the Tire Changer from the shipping pallet.
- 10. Move the Tire Changer to its to work location.
- 11. Connect to facility Power. **Requires a licensed Electrician.**
- 12. Connect to facility compressed air.
- 13. Prepare the Lube Bucket.
- 14. Grease the Assist Tower Post.
- 15. Test the Tire Changer.
- 16. Review the Final Checklist.

---

# Installation

This section describes how to install your Tire Changer. Perform the tasks in the order presented.

## Installation Safety Rules

**Pay attention at all times during installation.** Use appropriate tools and equipment. Stay clear of moving parts. Keep hands and fingers away from pinch points. **Safety is your top priority.**

Use caution when unpacking the Tire Changer from its shipping container and setting it up. The Tire Changer is heavy, and the weight is not evenly distributed; dropping or knocking over the unit may cause equipment damage and personal injury.

**⚠ WARNING** You **must** wear OSHA-approved (publication 3151) personal protective equipment at all times when installing, using, maintaining, or repairing the Tire Changer: leather gloves, steel-toed work boots, eye protection, back belts, and hearing protection.

Only experienced, trained technicians may install the Tire Changer. In particular, all electrical work **must** be done by a licensed Electrician.

**⚠ CAUTION** Certain parts of installing the Tire Changer are difficult for just one person. BendPak Ranger **strongly** recommends having two or more people work together to install the unit.

## Tools

You may need some or all of the following tools:

- Forklift, pallet jack, or shop crane
- Utility knife
- Hammer, mallet, crowbar, or pry bar
- Tin or sheet metal snips
- Hex key and wrench set, metric, and SAE
- Screwdriver set, Slot head and Phillips

Additional supplies you may need:

- Liquid or Paste Teflon thread sealant
- Anchor Bolts (Optional)
- Air fitting (Air In) to connect the Tire Changer to the shop's compressed air supply.

## Finding a Location

Keep the following in mind when deciding on a location:

- **Power source.** The Tire Changer needs to be near an appropriate power source.
- **Floor.** The Tire Changer is best used on a flat, Concrete floor.
- **Clearance.** The Tire Changer requires space around it. Refer to **Clearance** for more information.
- **Accessibility.** You need room to move the Wheels and Tires to and from the Tire Changer.
- **Danger.** When a Tire is on the Tire Changer, especially during Inflation, keep others far away; only the Operator should be within 30 feet of the Tire Changer when in use.

**Do not set up the Tire Changer in a well-travelled area or pathway.**

- **Keep Away from Water.** The Tire Changer has electrical components. If the Tire Changer becomes wet while power is applied, electronic components will most likely short circuit and require replacement.

**⚠ WARNING** Do not use the Tire Changer if it becomes wet or is setting in water. You could short circuit the electronic components in the Tire Changer, electrocute yourself, or bystanders. Or a slipping hazard may exist.

## Clearance

A suitable working area around the Tire Changer is required.

Allow room **above** the Tire Changer. BendPak Ranger recommends at least 12" (305 mm) of open space **above** the highest point of the Tire Changer.

**⚠ WARNING** The Clearance values shown here (looking down view) allows enough space to operate **around** the Tire Changer. **For safety purposes, only the Operator should be within 30 feet of the Tire Changer, while it is in use.**

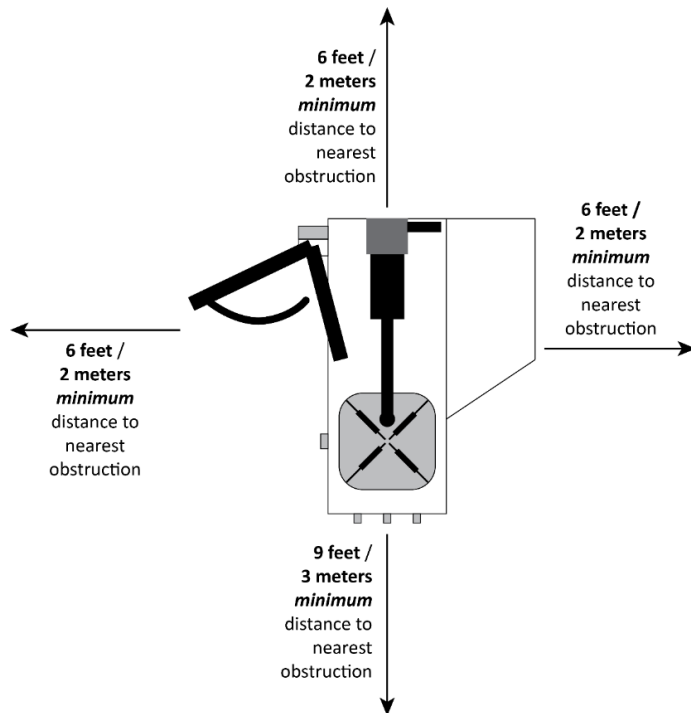

*Looking down view. Not to scale.*

## Unpacking

**Use caution when unpacking the Tire Changer from its shipping container.** Avoid damaging the unit, misplacing any of the components, or causing injury.

**⚠ WARNING** Make sure to use capable lifting straps with an appropriate lifting device, such as a Forklift, or use a Pallet Jack to move the Tire Changer while it is on its Pallet. Make sure only personnel who are experienced with material handling procedures are allowed to help move the Tire Changer. The Tire Changer is very heavy, and the weight is not evenly distributed; dropping or knocking over the unit may cause equipment damage or personal injury. BendPak Ranger recommends having at least two people work together to move the Tire Changer.

We recommend unpacking the Tire Changer in the area where it will be installed.

**⚠ WARNING** You **must** wear OSHA-approved (publication 3151) Personal Protective Equipment at all times when installing the Tire Changer: leather gloves, steel-toed boots, eye protection, back belts, and hearing protection are **mandatory**.

### To Unpack the Tire Changer:

1. The Tire Changer is attached to a pallet and protected with a thin wood cover. At the bottom of the cover, use a pry bar or screwdriver to push the metal tabs all the way down, on all four sides.

You may have to apply some force to set all the metal tabs free; they sometimes stick. Refer to the figure on the right.

2. Rotate the cover off and set aside.

**⚠ CAUTION** Ranger recommends having at least two people lift the cover off; it is heavy and awkward. If it is dropped or falls, it could cause injury or equipment damage.

3. Carefully remove the plastic protecting the Tire Changer and retain any parts located in bubble wrap or plastic bags
4. Remove the Accessory and Fasteners boxes, Bead Breaker Blade, and Turbo Blast Hose. Set aside where they will not be damaged.

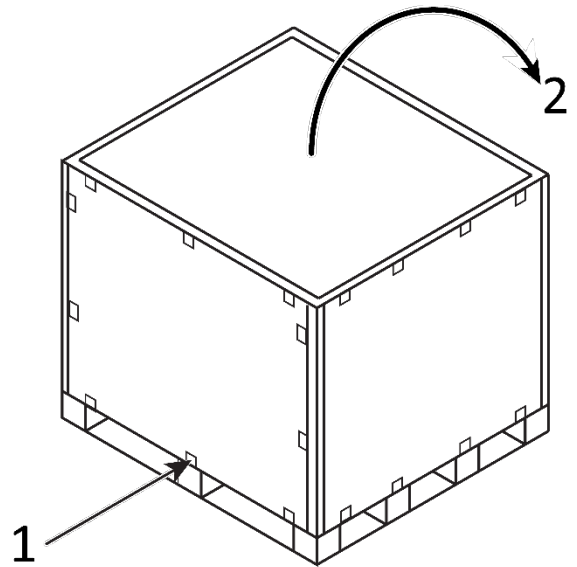

## Installing the Swing Arm Tower and Components

The Tower/Swing Arm, Inflation Gauge and Bead Breaker come uninstalled from the factory. You need to remove them from where they are secured on the shipping pallet and install them on the Tire Changer Cabinet.

### To install the Tower:

1. Make sure you are wearing OSHA-approved (publication 3151) Personal Protective Equipment: leather gloves, steel-toed work boots, back belts, hearing protection, and ANSI-approved eye protection (safety glasses, face shield, or goggles). Wear gloves and keep rags nearby to clean up excess grease.

**⚠ CAUTION** Ranger recommends having at least two people handle the Assist Tower and the Main Tower. They are heavy and awkward to move. If either Tower is dropped or falls, it could cause injury or equipment damage.

2. Retrieve the three M12 x 60 Hex Head Bolts and M12 flat washers from the Accessories and Fasteners box.
3. Cut the straps securing the Assist Tower to the Pallet and Tire Changer Cabinet.
4. With the help of an assistant, carefully move the Assist Tower aside.
5. The Swing Arm Main Tower is secured to the shipping pallet in several locations. **Carefully** remove the Bolts that secure the Tower to the Shipping Pallet.
6. Cut the strap that secures the Main Tower to the Changer Cabinet.
7. Remove and retain the Bolt used to secure the strap to the Swing Arm of the Tower.

**⚠ WARNING** Use care when moving the Tower; it is heavy and not evenly balanced. If it is dropped, you could injure yourself, and damage the unit.

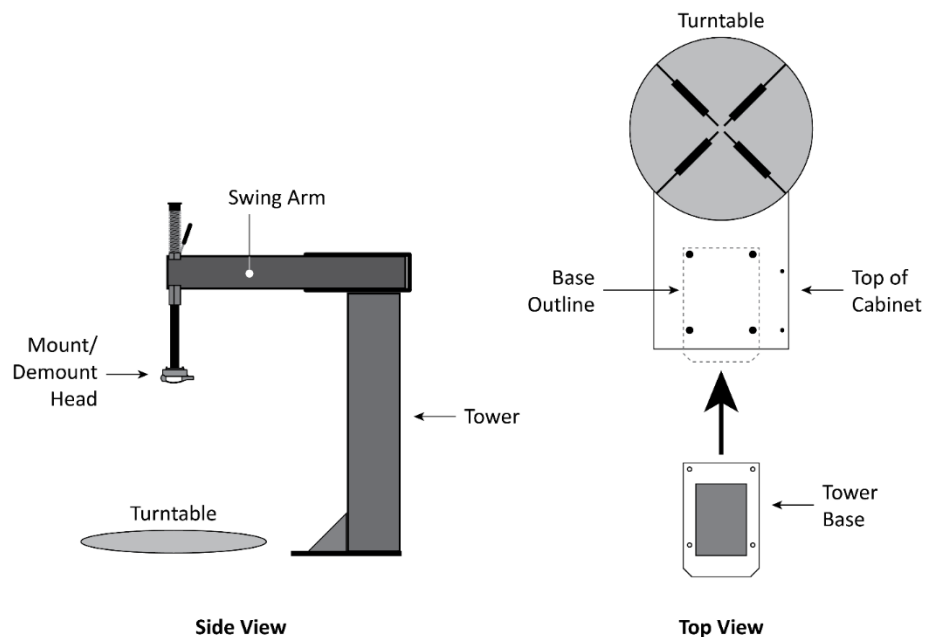
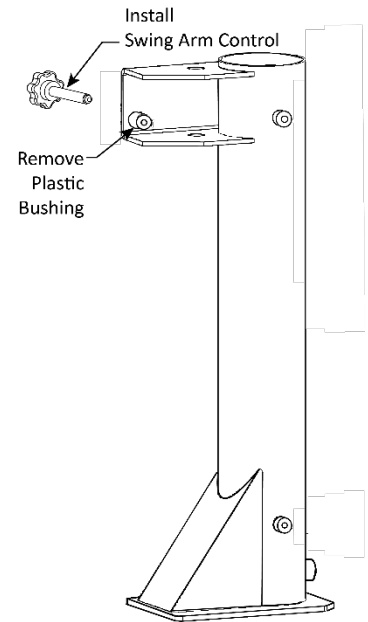

**⚠ CAUTION** Ranger recommends having at least two people handle the Assist Tower and the Main Tower. They are heavy and awkward to move. If either Tower is dropped or falls, it could cause injury or equipment damage.

8. With the help of an assistant, stand the Main Tower up on its base.
9. Using a Shop Crane or an Assistant carefully move the Main Tower onto the top of the Changer Cabinet. Move the Tower Base over the Tire Changer Cabinet, lining up the four holes in the Base over the four large holes in the top of the Cabinet. Make sure to orient the Tower so that the Mount/Demount Head (Duck Head) is over the Turntable.
10. Use the four Bolt/Washer pairs M12 x 60 and M12 flat washer to securely bolt the Tower into position on top of the Cabinet.
11. Retrieve the Turbo Blast Hose Assembly.
12. Apply Teflon Tape to the threaded joint where it connects to the Main Swing Arm Tower.
13. Connect the Turbo Blast Hose Assembly (730-1) to the Main Tower using the Moveable Joint (746). Take care not to lose or damage the O-Rings in this joint. Refer to the figure below.

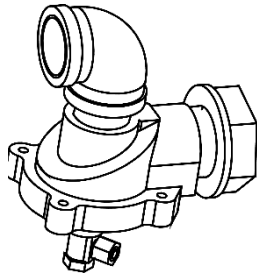

### Install the Bead Breaker:

1. Retrieve the Bead Breaker Blade from its plastic bag.
2. Remove the M14 x 95mm Bolt, lock washer, and Lock Nut.
3. Insert the Bead Breaker Blade on to the Bead Breaker Arm and secure with the M14 Bolt, lock washer and Nut just removed. Refer to figure on the right.

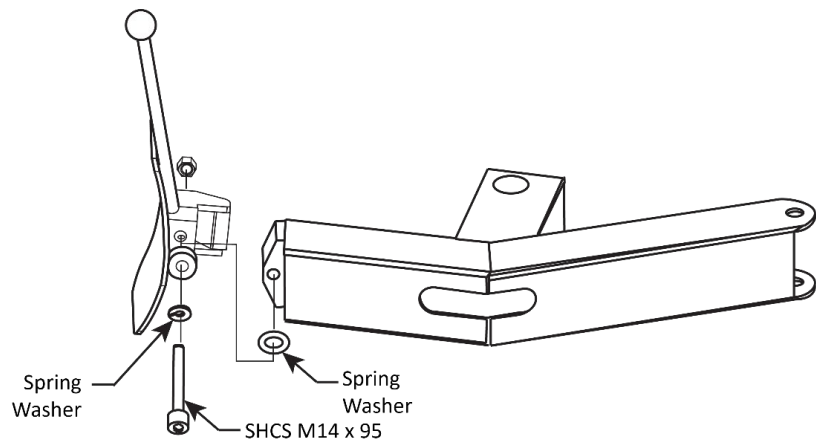

*Not to scale, not all components shown.*

## Connecting to Air Pressure

The Tire Changer requires a 15 to 25 CFM Air Source with an operating air pressure of 110 to 165 PSI (≈8 to 12 bar).

**Important:** The Tire Changer uses pneumatic and electrical energy; if your organization has Lockout/Tagout policies, implement them once the unit is connected to the Air Source.

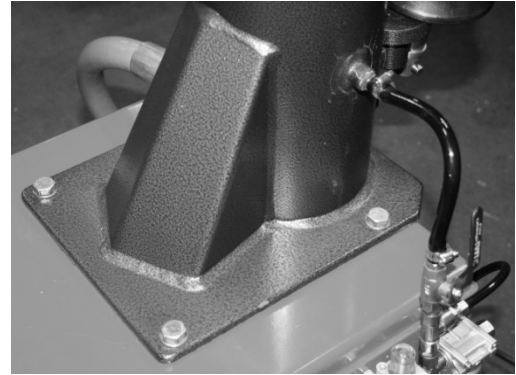

On the R980-DP/DPL the Dry Air Out must be connected to the Tower Tank.

The incoming Air Source connects to the Tire Changer via Air-In connector on the Regulator/Filter. You need to provide a fitting for the Air-In connector; not included.

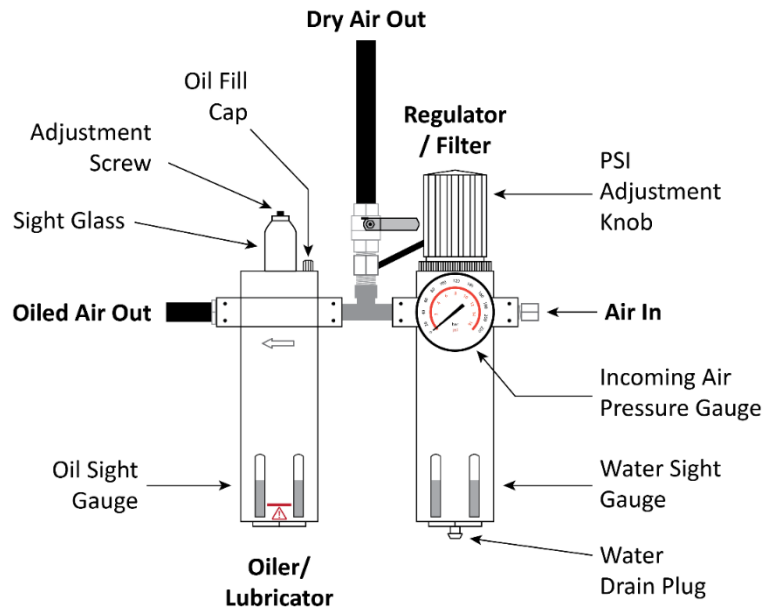

the

*Drawing not to scale. Not all components shown.*

The following drawing shows a quick-connect air fitting (shown on the right, below) that connects to the Air In connector (shown on the left, below). The fitting is **not** supplied with the Tire Changer.

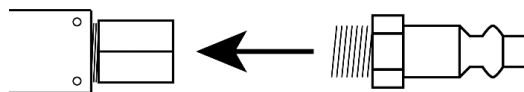

The **Regulator / Filter** removes contaminants from the incoming air. It also includes a gauge that shows the operating air pressure of the incoming air. If you see liquid in the Water Sight Gauge, you can drain it using the Water Drain Plug. Refer to **Maintenance** for more information.

The **Oiler / Lubricator** adds pneumatic oil, for lubrication, into the incoming air. This lubricated air is routed to pneumatic components of the Tire Changer.

### Attach the Toolbox to the Tower

1. Remove any protective plastic from the Tower and the Toolbox.
2. Remove the four M6 x 16 SCHS, Washers and lock washers from the Toolbox bracket on the Main Tower above the Air Connections.
3. Install the Toolbox using the M16 SCHS , flat washers and the lock washers just removed.



### To Install the Inflation Gauge:

1. Locate the Inflation Gauge bracket on the left side of the Tower above the Turbo Blast. The side opposite the compressed air input.
2. Remove and retain the two M6 x 10mm SCHS, lock washers and washers from the bracket.
3. Retrieve the Inflation Gauge from its bag or protective wrap and mount it on the side of the Tower. Orient the gauge so the air lines are exiting at the bottom. Secure using the screws, lock washers and the flat washers just removed.
4. Route the two air lines through the guides welded to the Tower and into the push-to-connect pneumatic fitting on the air line coming out of the back of the Tire Changer. Refer to the figure to the right. Connect like color tubes to like color tubes

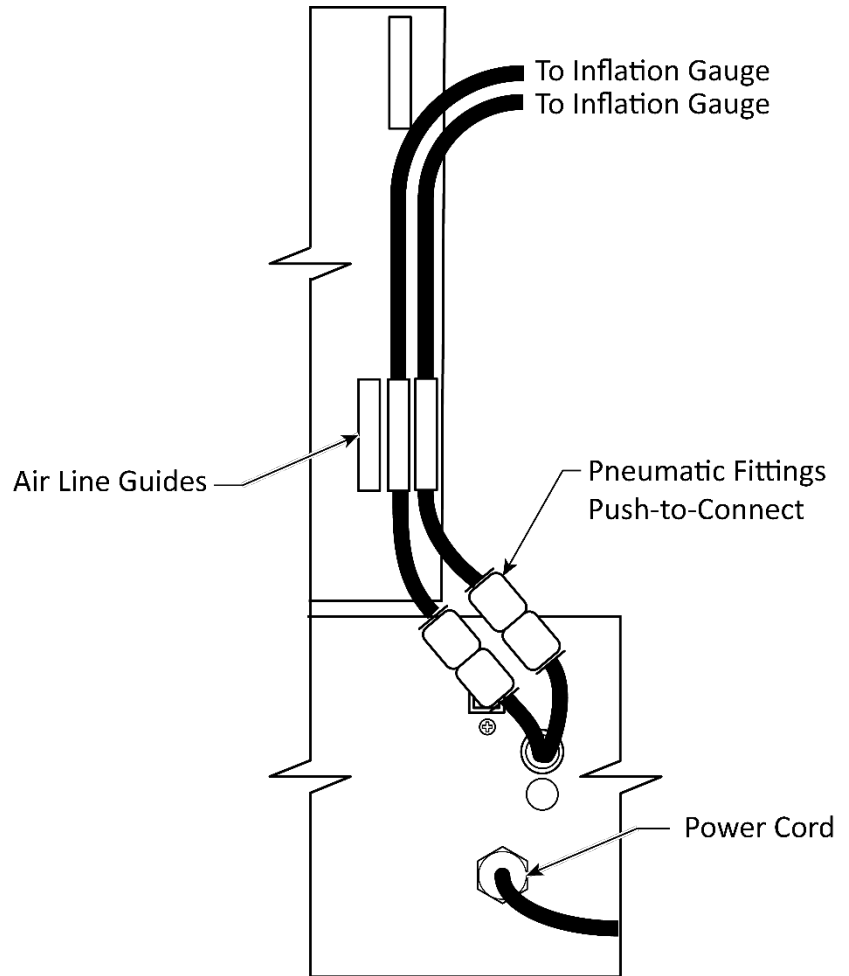

5. Install the Swing Adjustment Screw and Knob (208) into the Main Tower Swing Arm Bracket.

### Moving the Tire Changer:

1. Remove any final bolts holding the Tire Changer to its pallet.
2. Move a forklift into position with its forks over the Tire Changer table extending back toward the Main Tower.
3. Using Lifting suitable straps rated to support the Changer's weight, place one lifting strap around the front of the Tire Changer roughly on the centerline of the Turntable and a second strap at the rear of the Tire Changer as close to the Main Tower as possible. Lift the Changer a few inches off of the pallet and verify that the Changer is secured, is stable and is balanced.
4. Move the pallet out from under the Tire Changer.
5. Use the Forklift to carefully position the Tire Changer at the desired work location.
6. Carefully remove any additional packing and protective foam/plastic.
7. Remove excess shipping grease with clean rags.

## Anchoring the Tire Changer

The Tire Changer has openings in the base for anchoring it into place; anchoring is optional.

**Note:** Anchoring the Tire Changer is not required. However, BendPak Ranger recommends doing so, as the Tire Changer uses force at various times during the Tire changing process. Anchoring the Tire changer ensures it will not move during operation.

The three 0.5" / 12.7 mm holes for anchoring are located at:

- Front right
- Front left
- Rear right (under the Regulator/Filter)

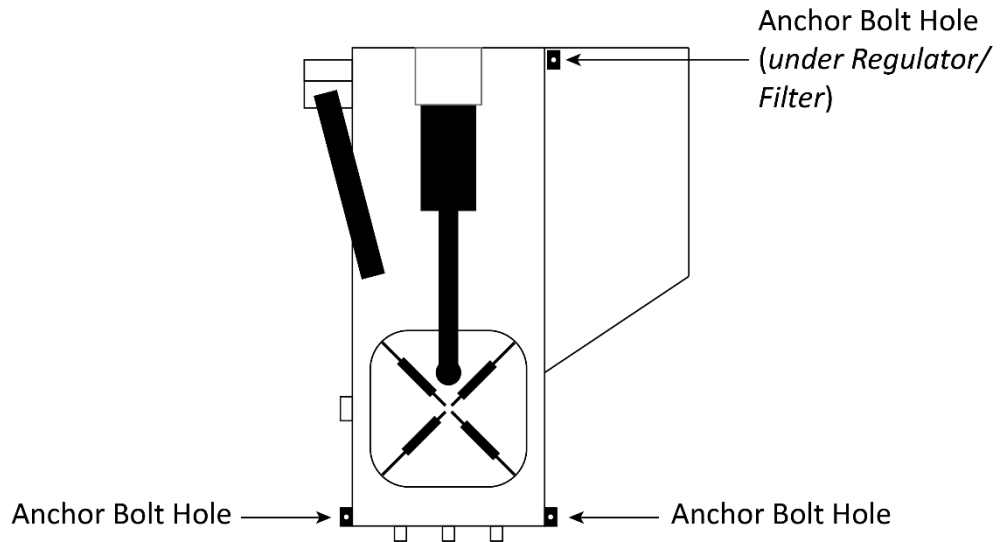

*Top down view.  
Not to scale.*

The Anchor Bolts (sometimes called Wedge Anchors) mentioned in the following procedure are **not** supplied with the Tire Changer. You could, for example, use 3/8" by 3" Anchor Bolts to secure the Tire Changer, drilling the hole approximately 2.5" / 63.5 mm deep into the Concrete.

### To anchor the Tire Changer:

1. Verify the Tire Changer is in the desired location.
2. Using the holes as guides, drill the holes for the Anchor Bolts.

**⚠ WARNING** You **must** wear OSHA-approved (publication 3151) Personal Protective Equipment at all times when installing the Lift: leather gloves, steel-toed boots, eye protection, back belts, and hearing protection are **mandatory**.



Go in straight; do not let the drill wobble. Use a carbide-tied drill bit (conforming to ANSI B212.15).

Use a drill bit that is the same diameter as the Anchor Bolt. So, if you are using a 3/8" diameter Anchor Bolt, for example, use a 3/8" diameter drill bit.

3. Vacuum each hole clean.

BendPak recommends using a wire brush and a vacuum to clean the hole.

Do **not** ream the hole. Do **not** make the hole any wider than the drill bit made it.

**⚠ WARNING** You **must** wear safety glasses when clearing debris from the anchor holes.

4. Make sure the Washer and Nut are in place, then insert the Anchor Bolt into the hole.

The Expansion Sleeve of the Anchor Bolt may prevent the Anchor Bolt from passing through the hole in the base of the Tire Changer; this is normal. Use a hammer or mallet to carefully tap the Expansion Sleeve through the base and down into the hole.



Even using a hammer or mallet, the Anchor Bolt should only go into the hole part of the way; this is normal. If the Anchor Bolt drops in with little or no resistance, the hole is too wide.

Once past the hole in the base, the Anchor Bolt eventually stops going down into the hole as the Expansion Sleeve contacts the sides of the hole; this is normal.

5. Hammer or mallet the Anchor Bolt the rest of the way down into the hole. Stop when the Washer is snug against the base of the Tire Changer.
6. Use a torque wrench to tighten each Nut **clockwise** to the torque recommended by the manufacturer of the Anchor Bolt. If no torque is specified, BendPak Ranger recommends ≈55 lb.-ft (74 N-m) for a 3/8" diameter Anchor Bolt.

**Important:** Do **not** use an *impact* wrench to torque the Anchor Bolts.

Wrenching the Nut forces the Wedge up, forcing out the Expansion Sleeve against the Concrete.

## Connecting to Power

The **R980DP-L** Tire Changer must be connected to a 110VAC power source on a **dedicated 20 Amp circuit**. The 110 VAC Unit's power cord is prewired with a plug.

**R980DP** Tire Changers must connect to a 240VAC power source; **20 Amp circuit**.

A Power Cord with **no Plug** on the end is provided with the 220 VAC unit. You must have a licensed Electrician either:

- Wire the **R980DP** Power Cord to an appropriate 208-240 VAC NEMA, 30 Amp Plug, which is then connected to an appropriate power outlet.
- or**
- Wire the Tire Changer directly into the facility's electrical system protected by an appropriate circuit breaker.

---

**Important:** The Tire Changer uses pneumatic and electrical energy; if your organization has Lockout/Tagout policies, implement them once the unit is connected to a power source.

Refer to **Wiring Information** for additional wiring information.

**⚠ DANGER** *All electrical work **must** be performed by a licensed Electrician in accordance with all local, state and National Electrical Codes (NEC). If you do not use a licensed Electrician, you void your warranty and expose everyone who uses the Tire Changer is in danger of injury or, in rare cases, death.*

Additional electrical information:

- Operation with no Ground circuit can damage electronics and could create a shock hazard. **You must Ground the unit.**
- Damage caused by improper electrical installation voids the warranty.
- The Tire Changer uses pneumatic and electrical energy; if your organization has Lockout/Tagout policies, make sure to implement them after connecting the unit to the power source.
- Make sure that adequate wire sizes are used, service is of adequate amperage rating, the supply line has the same electrical characteristics (voltage, cycle, and phase) as the motor, and that **no other equipment is operated on the same circuit.**
- Electrical codes in your area may require “hard wiring” if the machine is anchored to the floor. Consult a licensed Electrician regarding the applicable codes for your location.

**⚠ WARNING** ***Disconnect power and air pressure before performing any troubleshooting or maintenance.** Make sure the unit cannot be reenergized until you are done.*

**⚠ WARNING** This equipment has internal arcing or sparking parts that should not be exposed to flammable vapors. The unit must **not** be located in a recessed area or below floor level.

## Prepare the Lube Bucket

The Tire Changer arrives with a Lube Bucket (to hold your Lube) and a Lube Brush (to apply your Tire Lube).

BendPak Ranger does not include any Tire Lube with the Tire Changer, as there are many options available.

**⚠ CAUTION** Only use Tire Lube that is approved by the Tire manufacturer for the Tire you are changing. Using non-approved Lube could corrode the Wheel or cause Tire/Wheel slippage and vibration issues.

Be sure to use enough lubricant without using too much. The point of lubricant is to **temporarily** reduce the friction between the Tire Bead area and the Rim. Use a lubricant that is slippery when wet, but not slippery when dried. If you notice excessive amounts of lubricant on the Tire or Rim, remove the excess.

There is a location on the Tire Changer for the Lube Bucket: between the Bead Breaker and the Turntable.

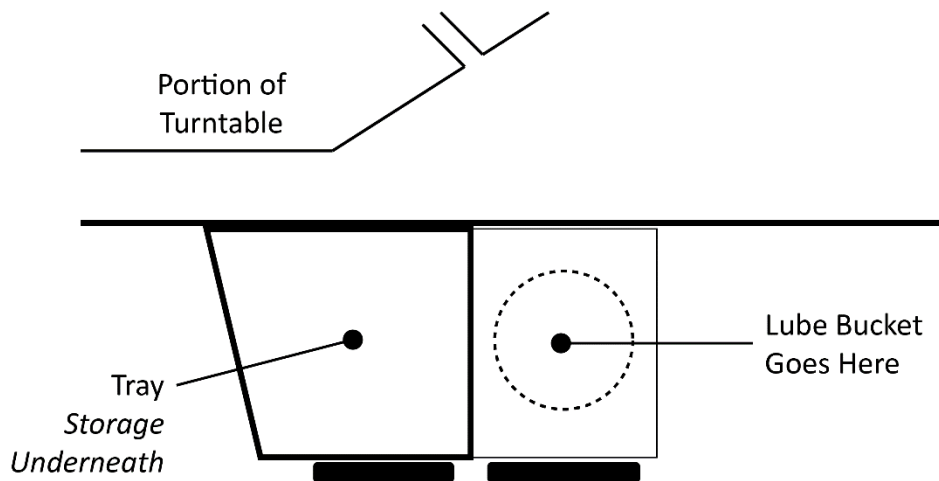

Top view. Not necessarily to scale. Not all components shown.

## Test the Tire Changer

Make sure the following items have been completed **before** operating the Tire Changer:

- **Check for pneumatic (air) pressure.** The Tire Changer requires pneumatic energy to perform certain functions.  
To determine if the Tire Changer has air pressure, hold the Air Chuck, and lightly step on and press down the Inflation Foot Pedal. If air comes out, the Air Source is connected and working.
- **Test the power source.** Other Tire Changer functions require electric power. Step on and hold down the Turntable Foot Pedal to check for electric power. If the Turntable turns, you have power.
- **Make sure there is Tire lubricant available.** Your shop probably has a brand of Lube that it prefers. Make sure some is in the Lube Bucket on the Tire Changer. Always use Lube; it makes changing Tires easier and helps prevent damage to the Tire and the Wheel.
- **Test the Tool Arms.** Manually move each Tool Arm separately from side to side. Use the Assist Tower Controls to raise and lower the Tool Arms (they move up and down together). If the Tool Arms can do these things, they are working correctly.
- **Change some non-customer Tires.** To become familiar with the Tire Changer, BendPak Ranger recommends that all potential Operators change an assortment of *non-customer Tires* before operating the Tire Changer.

## Final Checklist before Operation

Perform the following steps **before** operating the Tire Changer:

- Review the Installation Checklist to make sure all steps have been taken.
- Verify the Tire Changer is receiving electric and pneumatic power.
- Check to see that all Anchor Bolts are in position and tightened if you installed them.
- Make sure the Tire Changer has been used to change some non-customer Tires.
- Leave the Manual with the owner/operator.

---

# Operation

This section describes how to use the Tire Changer.

It describes the main components involved in demounting and mounting Tires, followed by the necessary procedures.

**⚠ DANGER** Occupying an area near a Tire Changer is a serious endeavor with potentially life-threatening risks. Only trained, authorized, supervised personnel may be within 30 feet of the Tire Changer while it is in use. **Do not assume you are going to be safe using the Tire Changer this time because nothing happened last time.**

## Usage Precautions

Keep the following in mind while you use your Tire Changer:

- Make sure all employees receive specific training in Tire demounting and mounting **before** they are allowed to use the Tire Changer, that their training is verified through a testing program, and that all training is documented. All others, including children and untrained personnel, must be kept at least 30 feet away from the Tire Changer while it is in use.
- Make sure new employees are trained and supervised in the performance of their duties.
- Never perform any service on an *inflated* Tire; **always** fully deflate the Tire by removing the Valve Core and letting the air escape before beginning work.
- Never mount or change **damaged** Tires or Wheels.
- When mounting Tires, identify the maximum allowed inflation pressure; it should be on the sidewall of the Tire. **Do not exceed the maximum allowed inflation pressure of the Tire.**
- Make sure the Tire is restrained for inflation: either internally clamped, held down by the Centering/Inflation Tool, or in a Tire Inflation Cage (such as the **RIC-4716 4-Bar Tire Inflation Cage from BendPak Ranger**). Do not inflate a Tire if it is externally clamped; external clamping interferes with inflation.
- When using the Tire Changer, be careful of your hands; there are multiple pinch point dangers on the unit. **Do not rest your hands on any part of the Tire Changer while using it.**

**⚠ WARNING** The Air Chuck has a self-gripping clip so that you can clip it on when inflating a Tire, which means you do not have to hold it in place during inflation. **Do not hold the Air Chuck while you are inflating a Tire.** This leaves you very close to the Tire, which could result in injury if there were a problem during the inflation. Instead, clip the Air Chuck into position, move away from the Tire, then press and hold down the Inflation Foot Pedal.

- You **must** wear OSHA-approved (publication 3151) personal protective equipment at all times when installing, using, maintaining, or repairing the Tire Changer. Leather gloves, steel-toed work boots, eye protection, back belts, and hearing protection **are mandatory**.
- When using the Tire Changer, the operator must wear **ANSI-approved** eye protection at all times: safety glasses, a face shield, or protective goggles.

**⚠ WARNING** Always wear ANSI-approved eye protection. An accident could cause significant injuries to your eyes.

- 
- The Tire Changer may work differently than other Tire Changers you have used. BendPak Ranger recommends practicing with non-customer Tires to become familiar with how the product works *before* starting work on customer Tires.
  - Keep the work area clean and well lit. Dirty, cluttered, and dark work areas increase the chances of an accident happening.
  - Do not access the inside of the unit unless instructed to do so by BendPak Ranger Support.

 **WARNING** Be especially careful when inflating Tires. Danger exists when using a Tire Changer. If the Tire and Wheel are mismatched or there is a defect in the Tire, it could explode, injuring or killing the Operator or bystanders. **Do not lean over the Tire when inflating a Tire.** Move away from the Tire during inflation.

- Do not use the Tire Changer in a wet environment or expose it to rain or excess moisture.
- If you need to use an extension cord to power the unit, use one with a current rating equal to or greater than that of the Tire Changer. Cords rated for less current than the Tire Changer could overheat. If used, arrange the extension cord so that it will not be tripped over or pulled out.
- Do not use anything flammable on the Beads or Rims as lubrication; instead, use non-flammable vegetable or soap-based rubber lubricant.
- Do not use the Tire Changer in the vicinity of open containers of flammable liquids.
- Clean the unit according to the instructions in **Maintenance**.
- Read the entire *Installation and Operation Manual* **before** using the Tire Changer.
- Make a visual inspection of the Tire Changer **before each use**. Do not operate the Tire Changer if you find any issues. Instead, take it out of service, then contact your dealer, visit [www.bendpak.com/support/](http://www.bendpak.com/support/), or call BendPak Ranger at **(805) 933-9970**, then follow the prompts.

## Turntable

The Turntable is where the Wheel and Tire are clamped for dismounting or mounting.

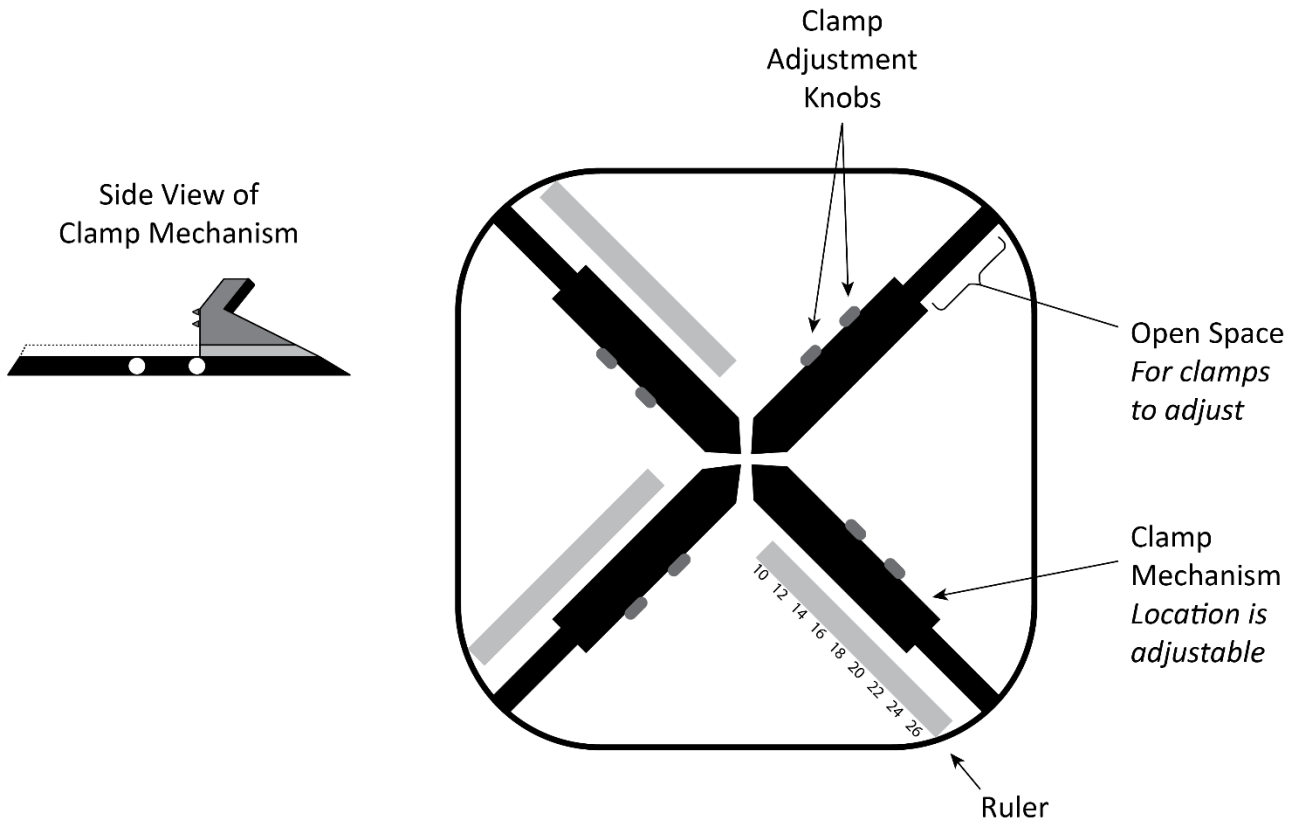

Top and side views. Not necessarily to scale. Not all components shown.

There are several important things to know about the Turntable:

- **Flat, steel piece.** This is the actual Turntable. It holds the other components. It can rotate either clockwise or counterclockwise.
  - To rotate the Turntable clockwise:** Press **down** on the Turntable Foot Pedal.
  - To rotate the Turntable counterclockwise:** Press **up** on the Turntable Foot Pedal.
- **Clamp Mechanism.** Each Clamp mechanism includes a Clamp and two Clamp Adjustment Knobs. The Clamp Mechanism moves in and out to clamp Wheels either externally or internally. “External” and “Internal” clamping refer to the location of the Clamp in relation to the Wheel.

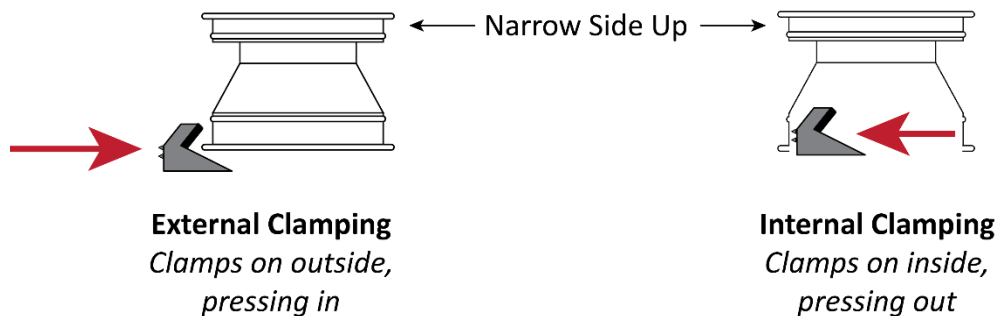

Side view. Some components exaggerated for clarity. Large arrows show direction Clamps are pressing. Only one of the four Clamps are shown. Not necessarily to scale. Not all components shown.



---

As a general rule, clamp steel Wheels internally (Clamps push out against Wheel) and custom and mag Wheels externally (Clamps push in against outside Rim edge). Check with a supervisor if you are unclear about which method to use for a particular set of Wheels.

**To clamp externally:** If necessary, use the Clamps Foot Pedal to move the Clamps all the way **out** (they may be all the way out already), position the Wheel between the Clamps, then press **down** on the Clamps Foot Pedal to move the Clamps **in** until the Wheel is being firmly held in place.

**To clamp internally:** If necessary, use the Clamps Foot Pedal to move the Clamps all the way **in** (they may be all the way in already), position the Wheel over the Clamps, then press down on the Clamps Foot Pedal to move the Clamps **out** until the Wheel is being firmly held in place.

**Note:** The Clamps Foot Pedal works as follows: If the Clamps are in the middle of the Turntable, pressing down and releasing the Clamps Foot Pedal moves them all the way out. If the Clamps are all the way out, pressing down and releasing the Clamps Foot Pedal moves them all the way back in.

- **Clamp Adjustment Knobs.** Move the Clamp between three different positions within the Clamp Mechanism to accommodate Wheels of different sizes.

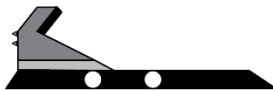

Clamp  
*outer position*



Clamp  
*center position*

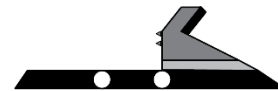

Clamp  
*inner position*

**To move a Clamp:** Pull out and hold the Clamp Adjustment Knob closest to the direction you want to move the Clamp, slide the Clamp in the desired direction, release the Clamp Adjustment Knob. If you want to move the Clamp again in the same direction, repeat the same procedure with the other Clamp Adjustment Knob. If the Clamp is in the center position, you can only move the Clamp one position in either direction.

## Pedals

The Tire Changer has four Foot Pedals:

- **Inflation, Foot Pedal.** Supplies air through the Air Pressure Gauge Cord.
- **Turntable, Foot Pedal.** Rotates the Turntable. Press down to go clockwise, press up to go counterclockwise.
- **Clamps, Foot Pedal.** Moves the Clamp Mechanisms in or out. Press down and release to move the Clamp Mechanisms out (if they are in), press down and release to move the Clamp Mechanisms in (if they are out). Pressing down and releasing the Clamps Foot Pedal moves the Clamps to the opposite location of where they were.
- **Bead Breaker Foot Pedal.** Press down to move the Bead Breaker Blade in; release the pedal to have the Bead Breaker Blade move back out to its starting position.

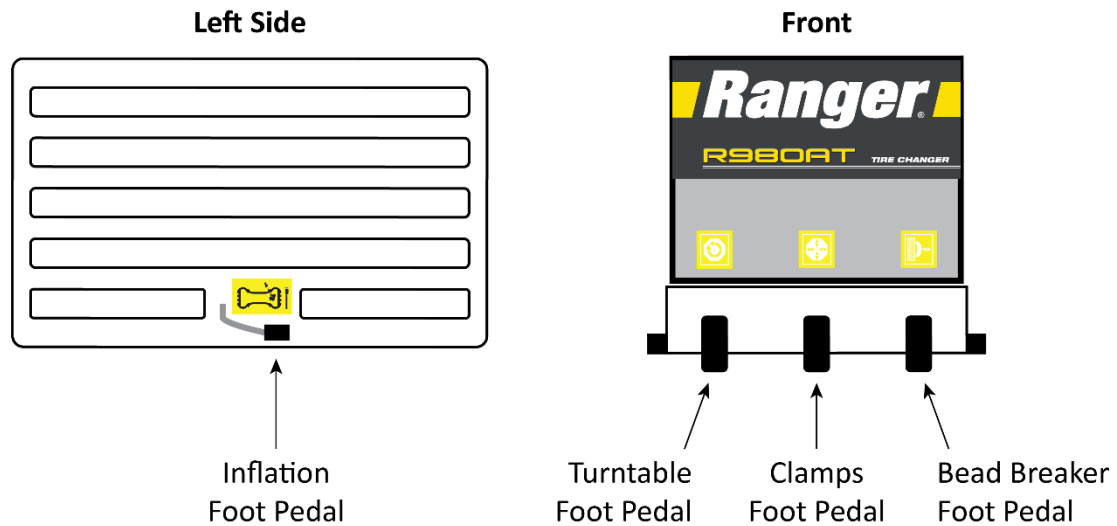

*Top view. Not necessarily to scale. Not all components shown.*

## Air Pressure Gauge

The components of the Air Pressure Gauge are:

- **Gauge.** Displays air pressure in the Tire, with Air Chuck attached.
- **Pressure Relief Button.** Releases air pressure.
- **Cord.** Extends and retracts to connect the Air Chuck to the Valve Stem. Self-Coiling
- **Air Chuck.** Attaches to the threads on the Valve Stem. Includes a self-gripping clip so you do **not** have to hold the Air Chuck in place during inflation.

**⚠ WARNING** **Do not hold the Air Chuck while you are inflating a Tire.** This leaves you close to the Tire, which could result in injury if there is a problem during inflation.

- **Threads.** Store the Air Chuck here using the self-gripping clip.

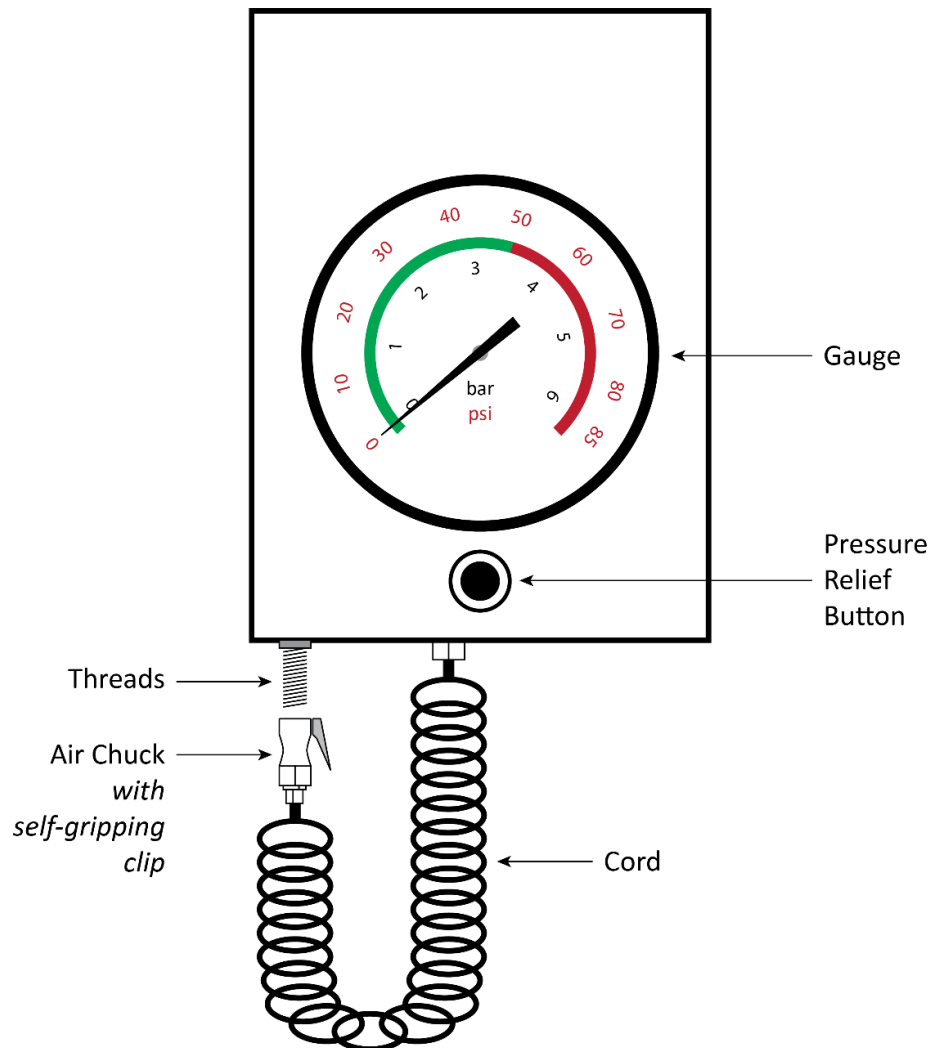

*Front view. Not necessarily to scale. Not all components shown.*

**To check tire air pressure:** Attach the Air Chuck to the Tire; the Air Gauge shows the air pressure currently in the Tire. You do **not** need to press the Inflation Foot Pedal.

**To see pressure during Tire inflation:** Attach the Air Chuck, lean away from the Tire, and press down the Inflation Foot Pedal. The Air Gauge shows the air pressure in the Tire as it inflates.

## Swing Arm

The Swing Arm holds the main Tire Changer Tool, the Mount/Demount Head (AKA Duck Head). It swings out of the way when not needed.

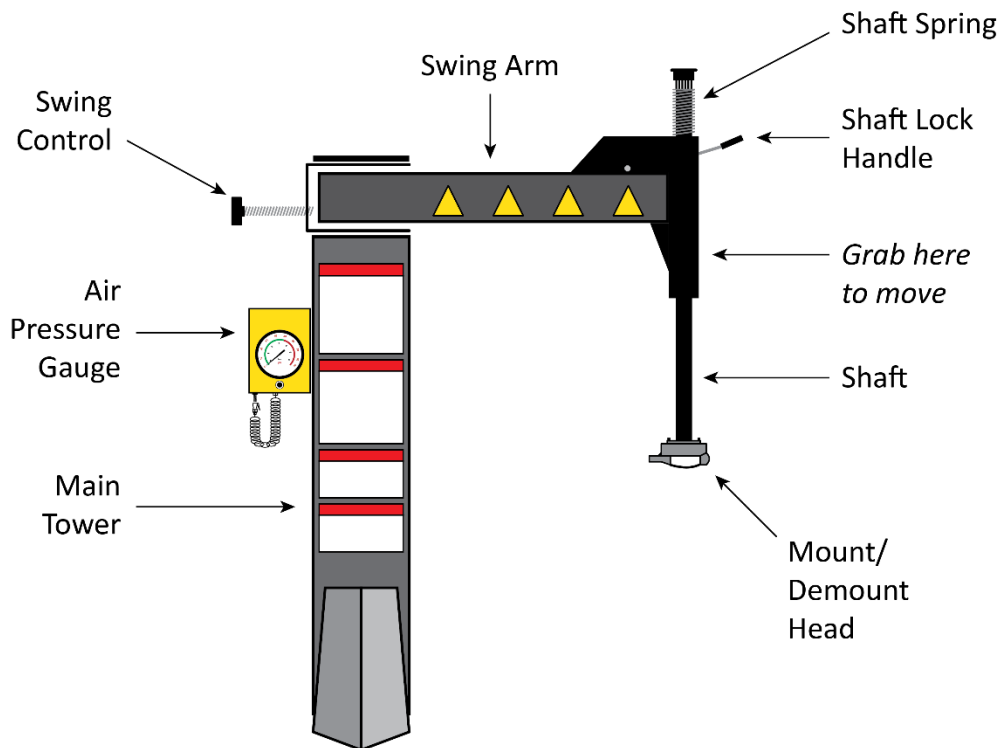

Front view. Swing Arm shown fully to the right. Not necessarily to scale. Not all components shown.

The main parts of the Swing Arm are:

- **Swing Arm.** When facing forward, moves the Mount/Demount Head (Duck Head) directly over the middle of the Turntable. From that position, the Swing Arm can swing up to 90° to the right, which lets you move out of the way as desired.
- **Swing Control.** Limits how far the Swing Arm can move. Makes sure the Mount/Demount Head cannot go past a point you control. Useful if you are going to be working on multiple Wheels that are exactly the same size; move the Mount/Demount Head to the desired location, then adjust the Swing Control so that the Swing Arm will return to this same position if moved out and then back.
- **Mount/Demount Head (Duck Head).** Attaches to the Bottom of the Shaft. The Swing Arm is to let you use the Mount/Demount Head where needed.
- **Shaft.** Moves the Mount/Demount Head up and down. Grab the Mount/Demount Head to move the Shaft up and down. Do not grab the Shaft, it is greased.
- **Shaft Lock Handle.** Locks the Shaft in position. Locking the Shaft moves it a very small amount up.
- **Shaft Spring.** Pushes the Shaft and the Mount/Demount Head back up when you release the Shaft Lock Handle.
- **Moving the Swing Arm.** Grab the end of the Swing Arm below the Shaft Lock Handle and above the Shaft to move the Swing Arm (location shown in the drawing above). Do not grab the Shaft itself, as it is greased.

## Mount/Demount Heads (Duck Head)

The Mount/Demount Head (aka Duck Head) is the main tool on the Tire Changer for demounting and mounting Tires.

The Tire Changer comes with two Mount/Demount Heads:

- **Alloy Steel.** Silver in color. Includes plastic inserts on the inside to avoid damaging Rims and a roller for extra mounting functionality.

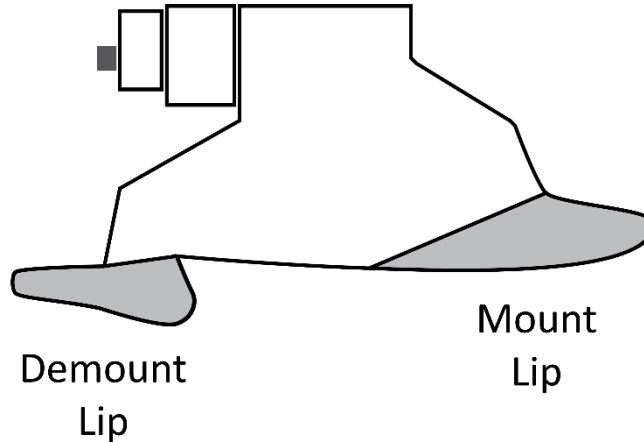

*Side view. Set Screws on other side. Not necessarily to scale. Not all components shown.*

- **Plastic Polymer.** Comes installed. Dark gray color. Non-marring surface will not scratch or otherwise damage paint or powder coating on wheels.

The following drawing shows the Plastic Polymer Mount/Demount Head (Duck Head) with the Demount and Mount Lips identified. It also shows where the Tire Bead goes during demounting and mounting.

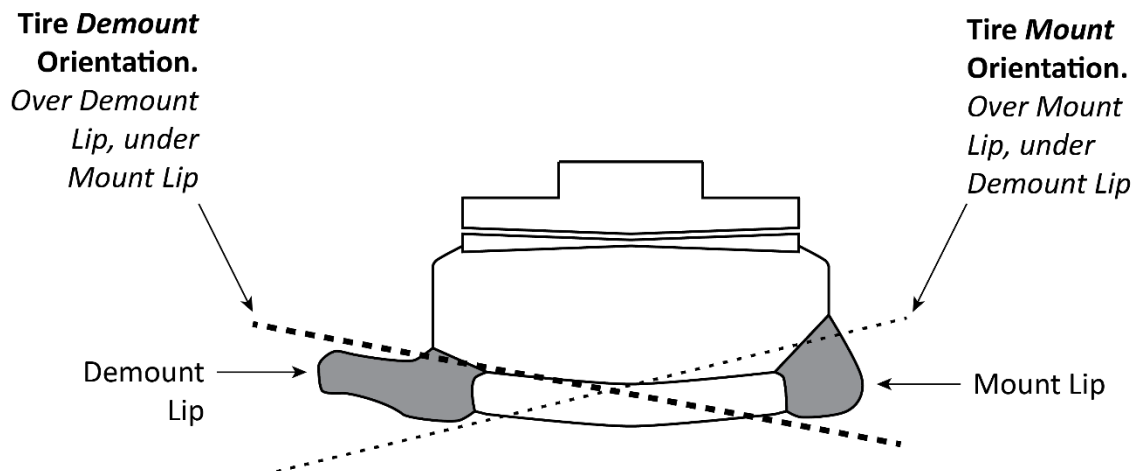

*Side view. Set Screws on other side. Not necessarily to scale. Not all components shown.*

The Demount Lip and Mount Lip work as follows:

- **During demounting.** The Tire Bead moves **over the Demount Lip** and *under the Mount Lip*.
- **During mounting.** The Tire Bead moves **over the Mount Lip** and *under the Demount Lip*.

You can easily switch between the two Mount/Demount Heads (Duck Head) using the two Set Screws and a 6 mm hex wrench. Simply loosen the Set Screws, slide the Head down and off, replace it with the other one, and tighten the Set Screws.

## Bead Breaker

Use the Bead Breaker to break the Beads (on both sides) of the Tires you are changing.

**⚠ WARNING** **Do not break the Beads of a Tire until you are certain the Tire is fully deflated.** Breaking the Bead of a Tire with air still in it could injure you or others nearby. The best way to be sure the Tire is fully deflated is to remove the Valve Core and wait for all of the air to exit.

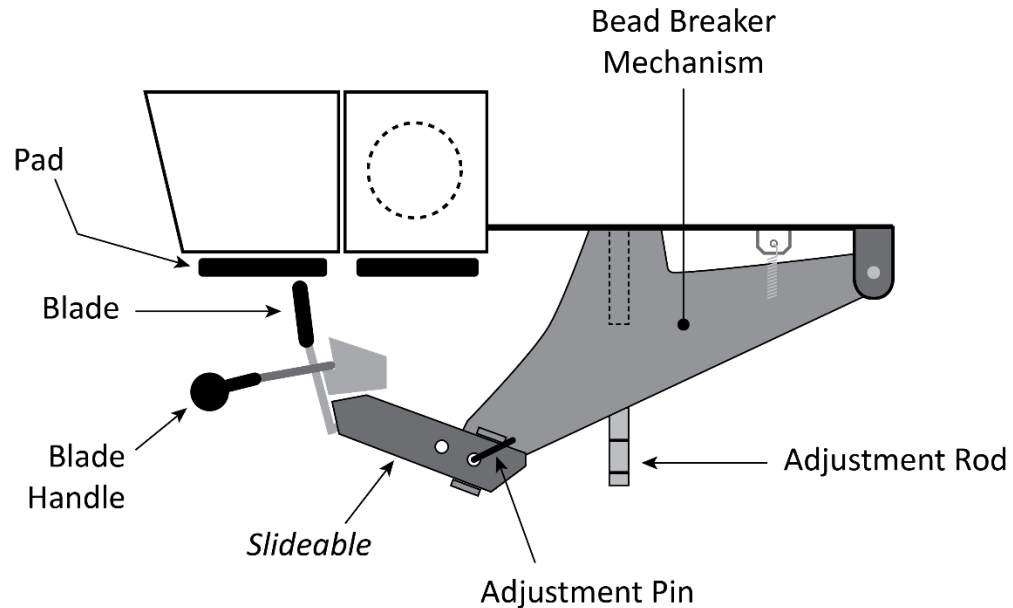

*Top view. Not necessarily to scale. Not all components shown.*

**⚠ WARNING** **There is a risk of crushing with the Bead Breaker.** Do not hold onto the Blade Handle when the Bead Breaker is moving. After positioning the Bead Breaker Blade, move away from the Bead Breaker, and make sure the area is completely clear, **before** pressing the Bead Breaker Foot Pedal.

The main parts of the Bead Breaker are:

- **Bead Breaker Mechanism.** Moves in and out under the control of the Bead Breaker Foot Pedal. Moves with great force; make sure you are completely clear of the Blade and the Bead Breaker Mechanism **before** pressing the Bead Breaker Foot Pedal.
- **Blade.** The part of the Bead Breaker that contacts the Tire and actually breaks the Bead.
- **Blade Handle.** Controls the Blade, moving it side to side and in and out.
- **Pads.** The side of the Tire where the Bead is **not** being broken rests against the Pads.
- **Adjustment Pin.** Allows you to accommodate Tires of different sizes by controlling the location of the Blade.

**To use the Adjustment Pin:** remove it from its current location, slide the metal piece holding the Blade to the other location, replace the Adjustment Pin.

- 
- **Adjustment Rod.** Allows you to accommodate Tires of different sizes by controlling the location of the Bead Breaker Mechanism.

When the Adjustment Rod is in the **In** locking position, the Bead Breaker Mechanism can come out further, accommodating larger Tire sizes.

**To use the Adjustment Rod:** Grasp the end of the rod, then move the outside of the rod from its current locking position to the other locking position.



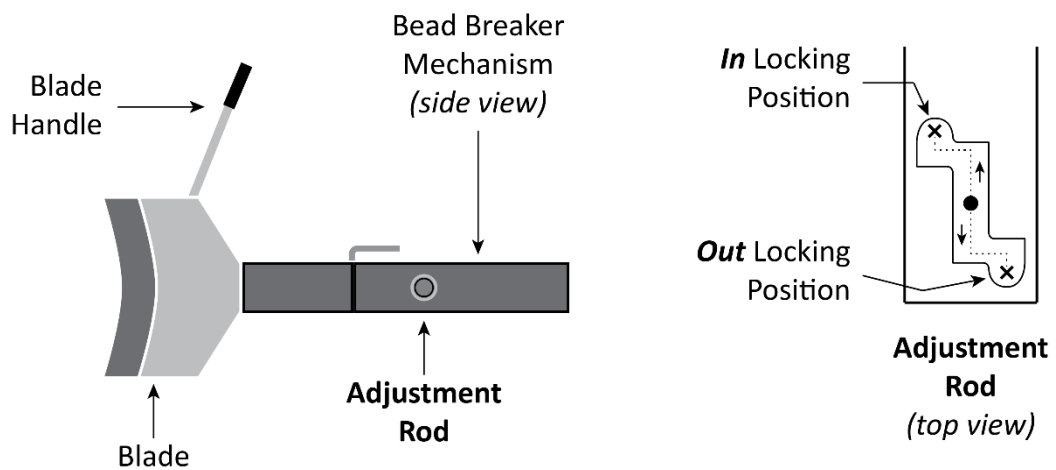
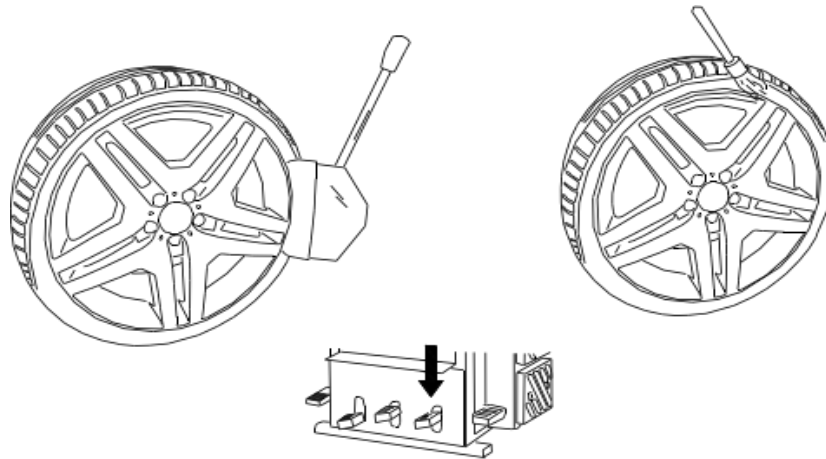

One side view, one top view. Not necessarily to scale. Not all components shown.

## Bead Lifting Tool

Use the Bead Lifting Tool to pull the Tire's Bead up and over the Mount/Demount Tool to help demount the Tire.

You can also use the Bead Lifting Tool to push down the Tire's Bead — to the left of the Mount/Demount Head (Duck Head)— during the mounting of a Tire.

The Bead Lifting Tool has an angled and a hooked end. You can use either end.





---

## Grease the Hexagonal Shaft

The Hexagonal Shaft requires grease as detailed below so that it can easily thread up and down.

The Tire Changer comes from the factory with the Hexagonal Shaft already greased. Re-grease the Post is service as required.

BendPak Ranger recommends a lithium-based grease that includes molybdenum and graphite. For example, Extreme Pressure Moly-Graph® Multi-Purpose Grease from CRC/Sat-Lube®.

**⚠ CAUTION** The lithium-based grease recommended for the Hexagonal Shaft is **not** a Tire lubricant. Do not use it to lube Tires. Once the Hexagonal Shaft is greased, avoid leaning on it, or touching it.

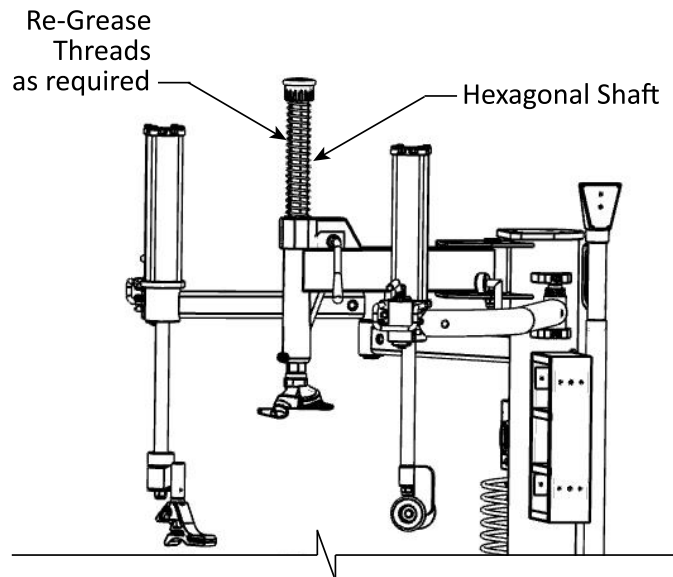

Side view. Not to scale. Not all components shown.

## Before You Change a Tire

**⚠ DANGER** Do not use the Tire Changer unless you have been properly trained and have read the entire *Installation and Operation Manual*. Tire changing must only be done by trained, authorized, supervised personnel. **Failure to understand and follow proper procedures may result in injury or death.**

Before you change a Tire, you should:

- **Remove existing weights.** Check the Wheel to make sure that all clip-on and adhesive weights (from having the Tire balanced) have been removed.
- **Deflate the Tire.** This is required. **You must fully deflate Tires before demounting them.**

To make sure a Tire is *fully deflated*, unscrew the Valve Core (Schraeder Valve) from the Valve Stem, using a Valve Core Removal Tool.

- **Have Tire lubricant ready.** Tire Lubricant makes the process of demounting and mounting Tires much easier. If you do not use Tire Lubricant, you significantly increase the chances of damaging the Wheel and the Tire. Tire Lubricant is not provided with the Tire Changer.
- **Check for damage.** Especially with expensive Wheels, make sure to check them for any damage *before* changing the Tire. Depending on the circumstances, if you find any damage you might want to discuss that damage with the owner of the Vehicle and/or photograph the damage. If you work in a shop, talk to your supervisor regarding shop policies in this area.

Additionally, damaged Wheels and Tires are dangerous to work with. If you are not sure whether a Wheel or Tire is too damaged to work with, talk to your supervisor.

- **Understand Performance Wheels.** Before servicing performance Wheels, review the Performance Wheels section of this manual.
- **Identify the Narrow Side/Drop Center of the Wheel.** The rule is: the Narrow Side/Drop Center side of the Wheel sets onto the Tire Changer facing up. For most Wheels, this means the side of the Wheel facing the *outside* of the Vehicle is positioned on top, because that's where the Narrow Side/Drop Center side is on most (but not all) Wheels.

The following drawing shows two Wheels and identifies the Narrow Side, Drop Center, and Wide Side of each.

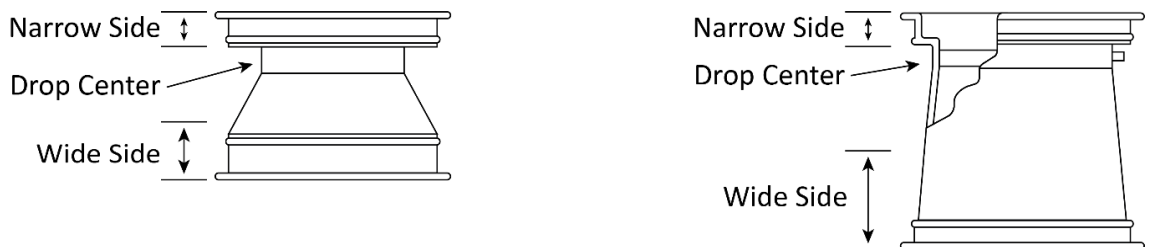

Some aftermarket and OEM performance Wheels are **reverse** drop-center Wheels, meaning the Narrow Side/Drop Center side of the Wheel is closer to the *inside* of the Vehicle. The rule still holds for these Vehicles: the Narrow Side/Drop Center side of the Wheel sets onto the Tire Changer facing up.

- **Ask your Supervisor.** If you have **any** concerns about a tire, you will be demounting or mounting, or about how to use the Tire Changer, consult with your supervisor **before** starting work.

---

## Working with Custom and Special Wheels

This section covers working with Alloy Wheels with no drop center, European performance Wheels, and Wheels with tire pressure monitoring systems.

### **Alloy Wheels**

Some manufacturers offer Wheels with little or no drop center. These types of Wheels are almost never approved by the Department of Transportation.

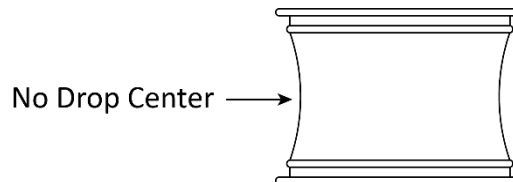

**⚠ DANGER** The Tire, Wheel, or both can be damaged, and the Tire could explode under pressure, resulting in serious injury or death. **BendPak Ranger recommends you not try to demount or mount this type of Wheel.** If you do attempt to demount or mount this type of Wheel, **proceed with extreme caution.**

### **European Performance Wheels**

Some European performance Wheels have very large humps; except near the Valve Hole. On these Wheels, the Beads should be loosened at the Valve Hole on both the upper and lower sides first.

### **Wheels with Tire Pressure Monitoring Systems (TPMS)**

Some Wheels have a pressure sensor located behind the Valve Stem. On these Wheels, the Beads should be loosened opposite the Valve Stem on both upper and lower sides first, before breaking the Beads on the rest of the Tire.

Performance Wheels on some Vehicles (including Corvette, BMW, and Lamborghini Diablo) have a pressure sensor strapped to the rim opposite the Valve Hole. On these Wheels, the Beads should be loosened at the Valve Hole on both the upper and lower sides first, before breaking the Beads on the rest of the Tire.

Be mindful of the TPMS sensor when breaking a Tire's Bead, demounting a Tire, and mounting a new Tire. If your shop does not have specific recommendations for handling these situations, BendPak Ranger recommends:

- **When breaking a Tire's Bead.** Keep the TPMS sensor away from where the Bead is being broken. Position the sensor at 12 o'clock high (relative to the ground) when breaking the Bead.
- **When demounting a Tire.** Position the TPMS sensor just to the right of the Mount/Demount Head.
- **When mounting a Tire.** Position the TPMS sensor just to the left of the Mount/Demount Head.

These are general guidelines; be sure to use common sense and take into consideration the specifics of each situation.

When finished mounting a Tire with a TPMS sensor, check that it is working. It is against the law to knowingly not re-install a working TPMS if the Vehicle arrived at the facility with a functioning TPMS. In other words, if a Vehicle came in with a functioning TPMS, it needs to leave with a functioning TPMS.

---

## The Steps in Changing a Tire

Before you start working on a Tire, review the requirements in [Before You Change a Tire](#).

Changing a Tire consists of multiple steps:

1. **Deflate the Tire.** There is a lot of energy stored in a Tire when it is inflated. You **must fully** deflate the Tire before you can demount it. If you do not, that energy will be released when you try to demount it, which could result in the Tire exploding, causing injury and even death to the Operator or bystanders. **Never work on a Tire unless you have personally confirmed that it is fully deflated.** The best way to do this is to make sure the Valve Core has been removed from the Valve Stem.
2. **Break the Bead.** Tires stay in position because the Tire Bead is seated between the Bead Retainer and the Rim Lip of the Wheel (called the Bead Seat). To demount a Tire, you must move the Bead out of the Bead Seat all the way around both sides of the Tire. This is called Breaking the Bead. Use care when Breaking the Bead of Wheels with a TPMS.
3. **Secure the Wheel on the Turntable.** It is important for the Wheel to stay in place on the Turntable. The Tire Changer supports both Internal and External Clamping.

 **WARNING** Do not stand on the Tire Changer Frame, or Turntable while demounting or mounting a Tire.

4. **Demount the Tire.** Once the Bead is broken, slide both Beads over the Rim Lip of the Wheel to remove. Once the Tire is demounted from the Wheel, remove it to mount the new Tire.
5. **Mount the new Tire.** Mounting a Tire is basically the opposite of demounting. Move the Beads under the Rim (the opposite of demounting the Tire), move the Beads into position **in** the Bead Seats (the opposite of Breaking the Bead), and then inflate the Tire (the opposite of deflating the Tire).
6. **Inflate the Tire.** Three separate stages: Bead Seal, Bead Seat, Inflate. **Bead Sealing** is adding an amount of air pressure to force the Tire against the Rim, so no air leaks out. **Bead Seating** is adding in more air pressure to “pop” the Beads into position in the Bead Seats. **Inflation** is adding air pressure to the Tire manufacturer’s recommended pressure after the Beads have been seated.
7. **Remove the Wheel from the Turntable.** Disengage the Clamps, then move the Wheel and Tire off the Turntable and back onto the ground.

---

## About Valve Stems

The following drawing shows a rubber Valve Stem and its components.

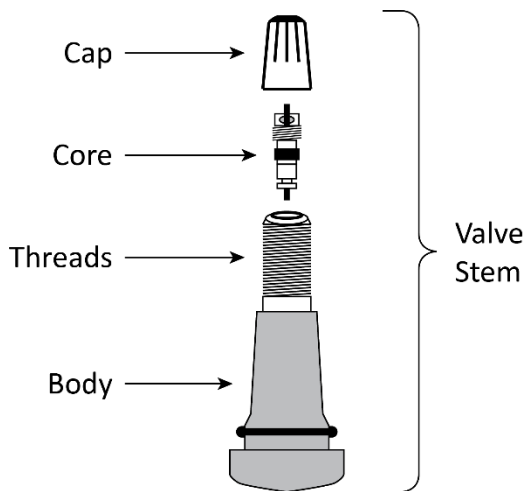

This manual talks about Valve Cores and Valve Stems at multiple points:

- **When demounting a Tire.** Unscrewing the Valve Core lets the air exit the Tire, which **must** be done before you can demount a Tire.  
It is dangerous to do any service on a Tire if it is holding air.  
Use a Valve Core Tool to unscrew the threaded Valve Core (Shrader valve).
- **When replacing the entire Valve Stem.** Valve Stems are normally replaced when you mount a **new** Tire on a Wheel.

When mounting a new Tire, BendPak Ranger recommends installing a new Valve Stem. The process for replacing a Valve Stem is to cut or pull out the old Valve Stem from the rim, then install the new Valve Stem. This should be done after the old Tire has been demounted, but before the new Tire is mounted (empty rim).

Use a Valve Stem Installer/Remover Tool (sometimes called a Valve Stem Puller/Remover Tool) that can be used to both remove an old Valve Stem and install a new Valve Stem from or into a rim.

**Generously lube the stem before installing.**

This tool is **not** the same tool as the Valve Core Tool.

---

## Break the Beads

Tire Beads must be broken (released/separated from its seat)– on both sides of a Tire – before the Tire can be demounted.

**⚠ WARNING** Do not Break the Bead of a Tire until **you** have made sure the Tire is fully deflated. A Tire with air still in it could explode, injuring the Operator or bystanders.

The Bead is broken when the Tire Beads come out from between the Rim Lip and the Bead Retainer (the Bead Seat) all the way around the Tire, on both sides of the Tire.

### To break a Tire's Beads:

1. Make sure you are wearing OSHA-approved (publication 3151) personal protective equipment: leather gloves, steel-toed work boots, back belts, hearing protection, and ANSI-approved eye protection (safety glasses, face shield, or goggles).
2. Check the Tire again to make sure it is **fully** deflated.
3. Check both sides of the Tire to make sure all Wheel weights (from balancing) have been removed. If they have not, remove them.

**⚠ CAUTION** Breaking the Beads of a Tire with Wheel weights could damage the Tire Changer and/or the Wheel.

4. Identify the Narrow side of the Tire whose Beads you are breaking; break this side first.
5. Move the Tire into position between the Pads and the Bead Breaker Blade, with the Narrow side of the Tire on the Blade side.
6. Depending on the size of the Tire whose Bead you are breaking, you may need to adjust the position of the Blade or use the Adjustment Rod to adjust the Bead Breaker Mechanism.

Refer to **Bead Breaker** for more information.

7. If you are Breaking the Beads of a Tire with a TPMS, place the sensor at 12 o'clock high or 6 o'clock low (relative to the ground), to reduce the chances of damaging it.



8. Move the Blade so that it is on the side of the Tire, very close to, **but not touching**, the Rim.

**⚠ CAUTION** Make sure the Blade is **not** touching the Rim. The Bead Breaker Mechanism uses a great deal of force; the Rim could be damaged if the Blade pushes on it instead of the side of the Tire.

9. Step on and hold down the Bead Breaker Foot Pedal.

The Blade pushes in, moving the Bead out of the Bead Seat and in towards the Drop Center of the Tire.

When the Bead breaks, it frequently (but not always) makes an audible popping sound.

10. If the Blade does not fully move the Bead out of the Bead Seat, adjust the Blade a little bit one way or the other and then step on and hold down the Bead Breaker Foot Pedal again.

11. When the Bead is broken, rotate the Tire 180° and break the Bead at that location.

Every Tire is different. With some Tires, the entire Bead on one side could be broken with the first use of the Bead Breaker Blade. Other Tires could take multiple attempts until the Bead is broken all the way around the Tire.

12. When the Bead is completely broken all the way around on one side of the Tire, move the Tire out, turn it around, and then break the Bead on the second side of the Tire.

Again, avoid breaking the Bead at the TPMS; you could damage the sensor.

**Important:** It may take two or three times to break the Bead at any one spot. Nevertheless, keep going until you break the Bead all the way around the Tire and on both sides of the Tire. Do not proceed to demounting the Tire until the Bead is broken all the way around and on both sides of the Tire.

## Secure the Wheel on the Turntable

Before you can demount a Tire, you must secure the Wheel on the Turntable.

The Tire Changer supports two ways of securing the Wheel to the Turntable:

- **External clamping.** The Clamps are on the outside, pressing inwards.
- **Internal clamping.** The Clamps are on the inside, pressing outwards.

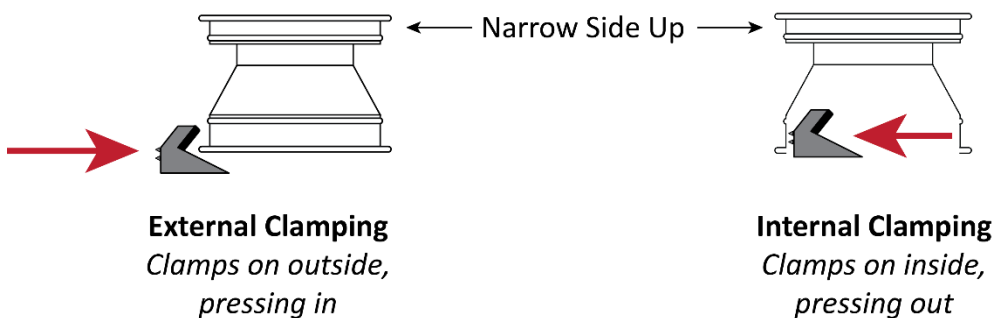

As a general rule, steel Wheels clamp internally (Clamps push out against Wheel) and custom and mag Wheels clamp externally (Clamps push in against outside Rim edge). Check with your supervisor if you are unclear about which method to use.

### To secure a Wheel on the Turntable:

1. Always wear OSHA-approved (publication 3151) personal protective equipment: leather gloves, steel-toed work boots, back belts, hearing protection, and ANSI-approved eye protection (safety glasses, face shield, or goggles) when operating the tire changer.

2. Identify the Narrow side of the Tire; this side faces up.
3. Determine which clamping method you are going to use.
  - If you are clamping externally, press **up** on the Clamps Foot Pedal to move the Clamps all the way **out**.
  - If you are clamping internally, press **down** on the Clamps Foot Pedal to move the Clamps all the way **in**.
4. Place the Wheel onto the Turntable, either between the Clamps that are all the way out for external clamping or over the Clamps that are all the way in for internal clamping.
5. Secure the Wheel:
  - If you are clamping externally, press **down** on the Clamps Foot Pedal to move the Clamps **in** until the Wheel is firmly held in place.
  - If you are clamping internally, press **up** on the Clamps Foot Pedal to move the Clamps **out** until the Wheel is firmly held in place.

**Tip**

Clamping externally can be difficult on some Tires. If you are having problems allowing the Clamps to clamp externally, either press down on the Wheel from above or, if you are using the R980DP, use the Restraint Cone to push the Wheel down from above. Pushing down from above moves the Rim away from the Tire, making it easier for the Clamps to grab the Rim.

## Demount the Tire

Demounting a Tire is the process of taking a Tire off a Wheel. Specifically, you need to pull the top Bead over the **top** of the Rim, then pull the bottom Bead also over the **top** of the Rim.

**CAUTION** You **must** use Tire lubricant; this makes the Tire demount more easily and helps to prevent damage to the Wheel and/or the Tire.

During demounting, the Bead moves over the Demount Lip of the Mount/Demount Head but stays under the Mount Lip. See **Mount/Demount Heads (Duck Head)** for additional information.

**WARNING** The following procedure **requires** that the Tire's Beads are broken on **both** sides. **Do not** try to demount a Tire whose Beads are not broken on both sides; you could damage the Wheel, the Tire, or even injure yourself or bystanders.

### To demount a Tire:

1. Make sure you are wearing OSHA-approved (publication 3151) personal protective equipment: leather gloves, steel-toed work boots, back belts, hearing protection, and ANSI-approved eye protection (safety glasses, face shield, or goggles).
2. Verify that the Tire's Beads are completely broken on both sides of the Tire.
3. Apply Tire lubricant to both the top and bottom Tire Beads and the top and bottom Rim.  
This helps slide the Beads over the Rims more easily.
4. Move the Mount/Demount Head (Duck Head) into position, very close to the Rim **but not touching it**, and lock it in position using the Shaft Lock Handle.



**Tip**

If you are working on multiple Wheels of exactly the same size, you can “lock” the Mount/Demount Head to this location using the Swing Control, located next to the Swing Arm at the top of the Tire Changer. Refer to **Swing Arm** for more information.

At this point, the top Bead is under both the Mount Lip and the Demount Lip; it needs to be brought up over the top of the Demount Lip.

5. Push the top Bead 180° opposite the Mount/Demount Head into the Drop Center of the Wheel.

This gives you some extra room to help pull the top Bead over the Demount Lip.

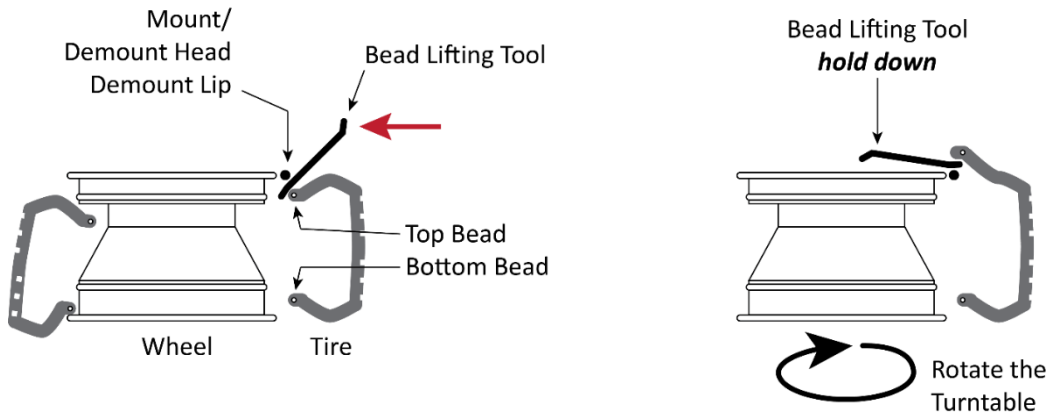

*Tires not shown for clarity. Side view. Not necessarily to scale.*

6. Take the Bead Lifting Tool, position one end on the outside of the Demount Lip of the Mount/Demount Head, then slide it down between the Demount Lip and the top Tire Bead until it is just past (and a little under) the Bead.
7. Carefully push the Bead Lifting Tool in towards the middle of the Wheel in an arc.

This pulls the top Bead over the Demount Lip of the Mount/Demount Head, which is what you want.

**CAUTION** **Secure the Bead Lifting Tool.** Depending on the Tire, it may take a good deal of force to move the Bead up and over the Demount Lip. If you were to release the Bead Lifting Tool at this point, it may injure the Operator or damage the Wheel, Tire, or the Tire Changer.

Check to make sure the Bead Lifting Tool is lifting the Tire Bead up and over the Demount Lip of the Mount/Demount Head. If the Tire Bead is **not** coming up and over the Demount Lip, pull the Bead Lifting Tool out and start again.

8. When the Bead Lifting Tool has moved all the way over to the middle of the Wheel, check the top Bead to make sure it is above the Demount Lip.

The top Bead **must** be above the top of the Demount Lip to proceed.  
*Continue holding the Bead Lifting Tool.*

9. Press down the Turntable Foot Pedal so that the Turntable begins turning clockwise.

**Note:** If there is difficulty allowing the Turntable to move clockwise, release the Turntable Foot Pedal, keep hold of the Bead Lifting Tool, and then press up on the Turntable Foot Pedal for few seconds to move the Turntable counterclockwise, then press down again to move clockwise. Repeat as necessary to clear up the difficulty.

Watch the top Bead to make sure it is being pushed over the Rim, all the way around the Tire, as the Turntable moves.

10. Keep turning the Turntable until the entire top Bead pops over the top of the Rim.
11. When the top Tire Bead pops over the Rim, release the Turntable Foot Pedal, and remove the Bead Lifting Tool.

The top Bead is demounted.

The next step is to demount the bottom Bead over the top Rim.

12. Make sure there is still lubricant on the bottom Bead and the top Rim.

If there is not, apply again.

13. Push the bottom Bead up as much as possible all the way around the Wheel, then push the side of the Tire opposite the Mount/Demount Head into the Drop Center of the Wheel.

If you are using the R980DP, you can position the Helper Disc to hold up the side of the Tire opposite the Mount/Demount Head.

14. Take the Bead Lifting Tool, place it on the outside of the Demount Lip, then slide it down past and under the bottom Bead.

Moving the Bead Lifting Tool into position may be trickier this time, as the rest of the Tire is in the way as you are trying to gain access to the bottom Bead.

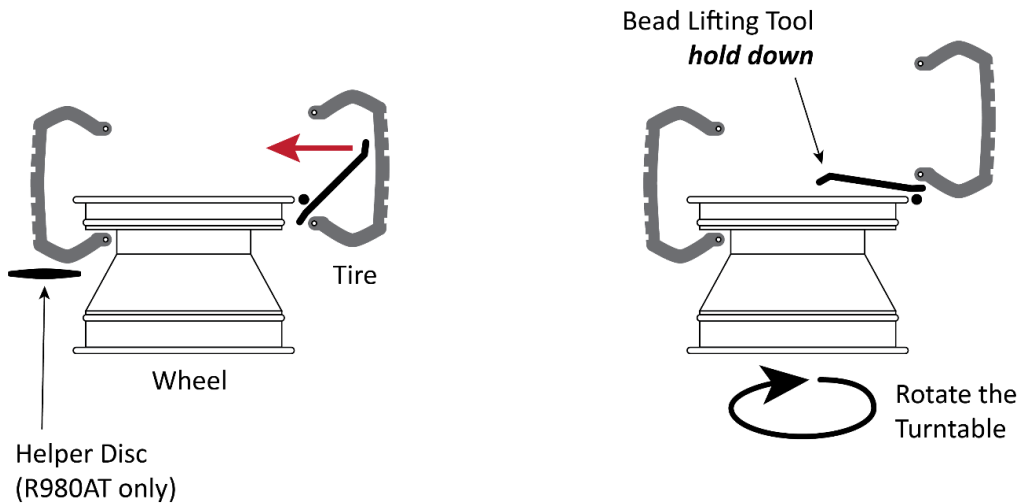

*Tires not shown for clarity. Side view. Not necessarily to scale.*

15. Push the Bead Lifting Tool towards the middle of the Wheel in an arc, pulling the bottom Bead over the Demount Lip of the Mount/Demount Head.
16. While continuing to hold the Bead Lifting Tool, press down on the Turntable Foot Pedal to move the Turntable clockwise.

Watch the bottom Bead to make sure it is being pushed over the top of the Rim as the Turntable moves.

17. Keep turning the Turntable until the entire bottom Bead pops over the top Rim.

The Tire is now dismounted and can be removed.

## Mounting a New Tire

**⚠ WARNING** Mounting a new Tire can be hazardous if done incorrectly. Do not change a Tire unless you have been trained. Failure to understand and follow proper procedures can result in injury or death.

During mounting, the Tire Bead moves over the Mount Lip of the Mount/Demount Head, but stays under the Demount Lip. See **Mount/Demount Heads** (aka Duck Head) for additional information.

Review the following points before mounting a Tire:

- Check the Tire and Wheel to make sure they are an **exact** match.
- Replace the Wheel's Valve Stem before mounting the Tire.
- Consider using the Alloy Steel Mount/Demount Head, as it has a built-in Roller that helps to keep the Sidewall of the Tire stay under the Mount/Demount Head.
- Make sure the Wheel is both clean and free of balancing weights. Remove any weights and any corrosion you find on the Wheel; **do not** service heavily corroded Wheels.
- Check the Tire for damage; **do not mount a damaged Tire**.
- Check the location of the TPMS and adjust the Tire if necessary. Do not damage the sensor.
- Check for yellow and red dots. If found, line them up with the appropriate locations on the Tire.
- Make sure the valve core is removed from the valve stem.

### Before Installing or Replacing a Tire, Note the Following:

With the rim secured on the Turntable, move the Vertical Shaft and mount/demount head (Duck Head) gently down to contact the rim's edge.



Pull the locking handle towards you to lock the Vertical Shaft into position. As the Shaft is locked, the Mount/Demount Head will move upward approximately 1/8" and backward 1/8" from the rim's edge, thus providing operating clearance.

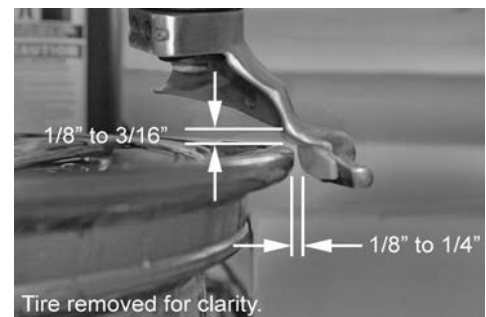
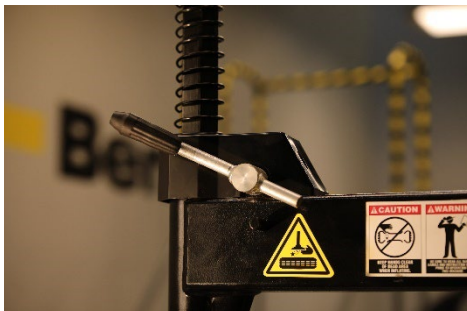

When replacing a series of tire and wheel combinations that all match in size, the operator may swing the arm out of the way and back into place again when changing the like set of wheels. Monitor the Mount/Demount head (Duck Head) so that it is never in contact with the rim's edge during installation or removal of any tire.

Important: The Mount/Demount head (Duck Head) set clearance will normally hold as long as the vertical shaft remains locked, but should be periodically checked during use. This is because the tool clearance may change with operational use. Failure to maintain and/or monitor proper clearance may result in damage to the wheel rim or tire.

## To Install or Replace a Tire:

1. Wear OSHA-approved (publication 3151) personal protective equipment: leather gloves, steel-toed work boots, back belts, hearing protection, and ANSI-approved eye protection.
2. If the Wheel is not already secured on the Turntable with the Narrow Side facing up, move the Wheel onto the Turntable and secure it internally or externally.
3. Apply Tire lubricant to the top and bottom Beads and the top and bottom Rims.
4. Place the Tire over the Wheel, with the side that will be next to the Mount/Demount Head low and the other side high (above the top of the Wheel).
5. Swing the Mount/Demount Head into position.
6. Bring up the low side of the Tire and place the **bottom** Tire Bead over the Mount Lip and under the Demount Lip.

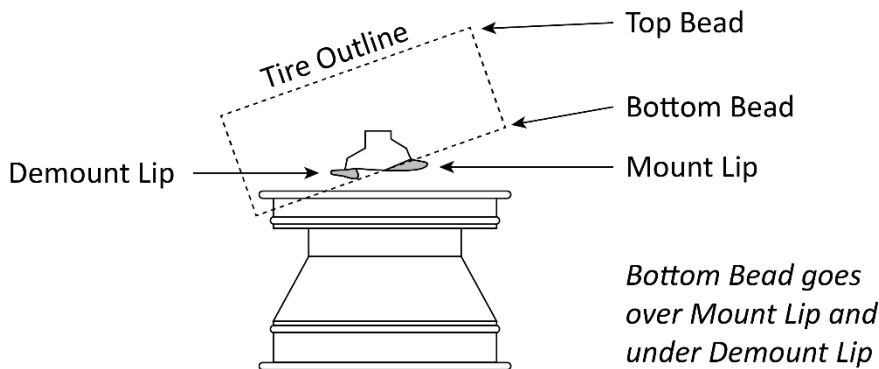

*Side view. Not to scale.*

7. Push the side of the Tire furthest away from the Mount/Demount Head down over that side of the Rim and Wheel as far as it will go.
8. Press down on the Turntable Foot Pedal.  
The Turntable will rotate clockwise, and the bottom Tire Bead will drop over the top of the Rim.
9. Place the **top** Tire Bead over the Mount Lip and under the Demount Lip.

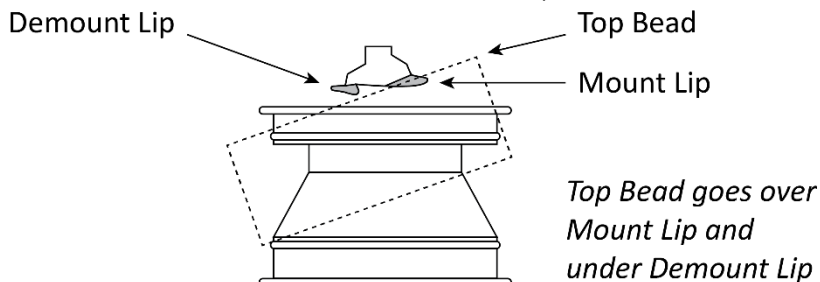

*Side view. Not to scale.*

10. If using the Alloy Steel Mount/Demount Head, swing the built-in Roller into position on the Sidewall of the Tire.
11. Position the Bead Lifting Tool to the left of the Mount/Demount Head (about 20 percent of the distance around the Tire), with the Bead Lifting Tool pushing down on the Sidewall of the Tire.

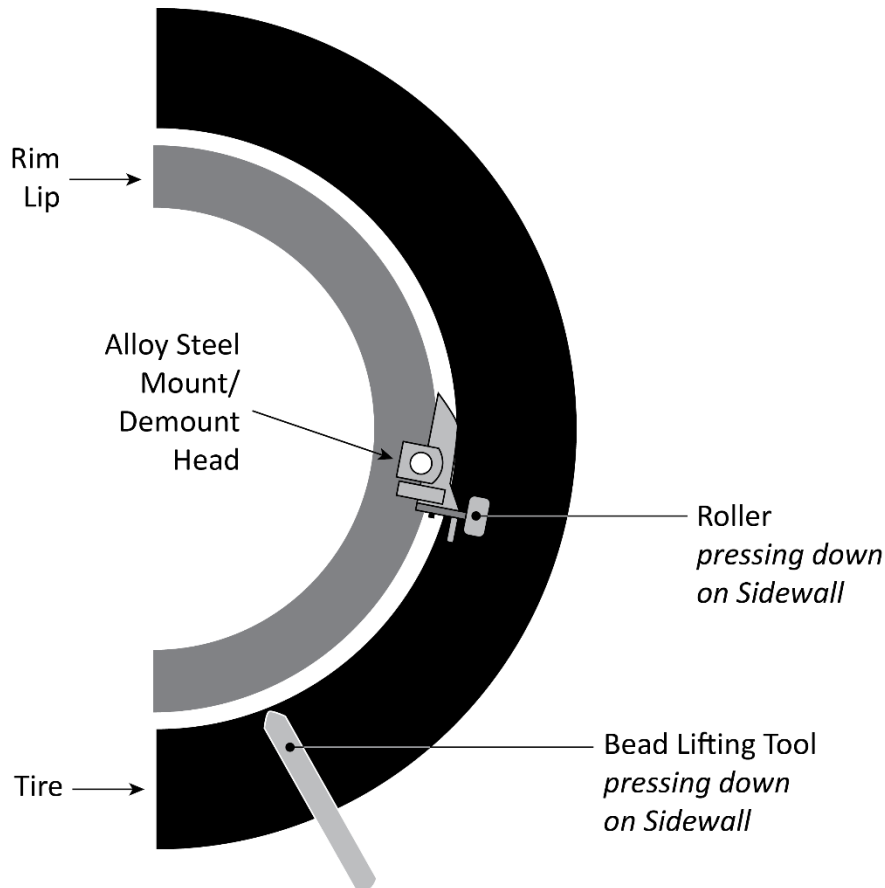

*Top view. Not to scale.*

12. When you start rotating the Tire, move the Bead Lifting Tool around as the Tire moves around, keeping the Tool at the same spot on the Tire.
13. If using the R980DP, position the Assist Tool to the left of the Mount/Demount Head (about 20 percent of the total distance around the Tire), with the Assist Tool pushing down on the Sidewall of the Tire.

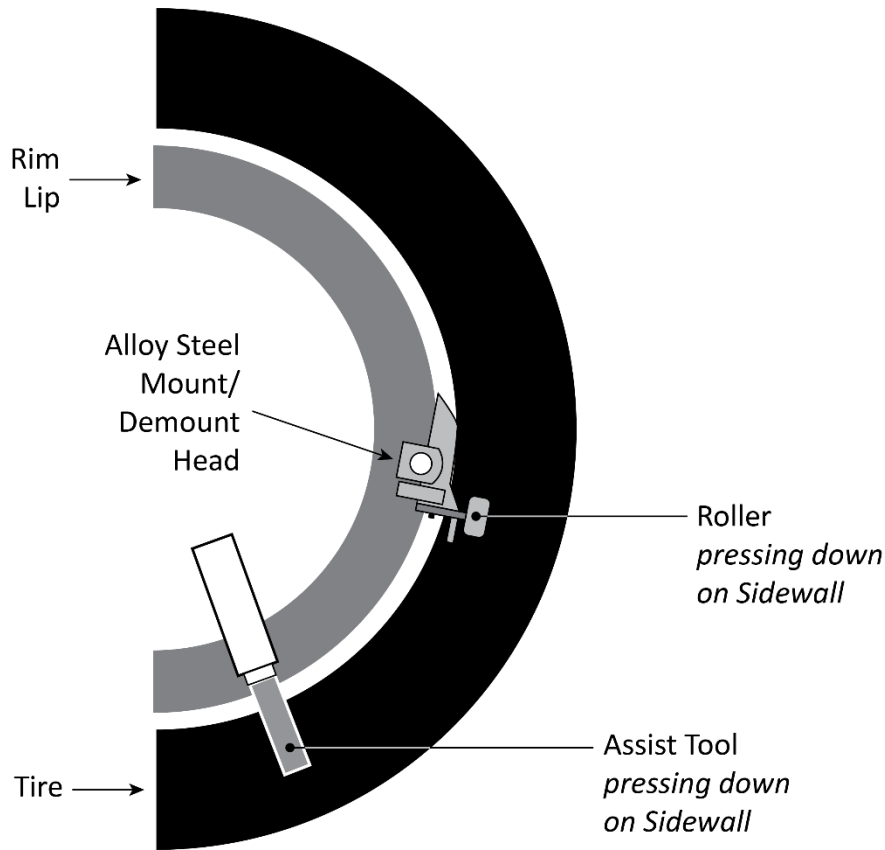

*Top view. Not to scale.*

When you start rotating the Tire, move the Assist Tool around as the Tire moves around, keeping the Tool at the same spot on the Tire.

14. Press down on the Turntable Foot Pedal to move the Turntable clockwise.

If using the Bead Lifting Tool or Assist Tool to hold down the Sidewall starting near the Mount/Demount Head, move them around with the Tire as it rotates.

15. If you run into any difficulty as the Tire rotates, remove your foot off the Turntable Foot Pedal to stop the Turntable, then press up on the Turntable Foot Pedal to turn the Turntable counterclockwise. Make any necessary adjustments and then proceed.

Eventually the top Tire Bead slips under the Rim. How long this takes can vary, based on the Tire you are mounting.

The Tire is now in place around the Wheel Rim. The next step is to inflate the Tire.

### **When Sealing the Beads:**

1. Wear OSHA-approved (publication 3151) personal protective equipment: leather gloves, steel-toed work boots, back belts, hearing protection, and ANSI-approved eye protection (safety glasses, face shield, or goggles).
2. Make sure the Valve Core has been removed.
3. Clip the Air Chuck to the Valve Stem.

The Air Chuck includes a self-gripping clip, so you do **not** have to hold it in place during inflation.

**⚠ WARNING** **Do not hold the Air Chuck while you are inflating a Tire.** This leaves you close to the Tire, which could result in injury if there is a problem during inflation.

4. Press and hold down the Inflation Foot Pedal for a second or two.

Air travels into the Tire and seals the Bead.

Bead Sealing takes very little air pressure, anywhere from 0 to 3 psi, which you can monitor on the Pressure Gauge.

The Bead is sealed when there is no sound of air coming out from the Wheel Rim and the Tire Beads.

5. Check to make sure the upper and lower Beads are sealed against the Rim.

If the Beads are **not** sealed, try again, while adding slightly more air.

6. If the Bead is still not sealed, position the Turbo-Blast™ nozzle about an inch from where the Wheel meets the Rim Edge and press the Button. You want the air blast to go under the Rim and into the Tire, sealing the Bead.

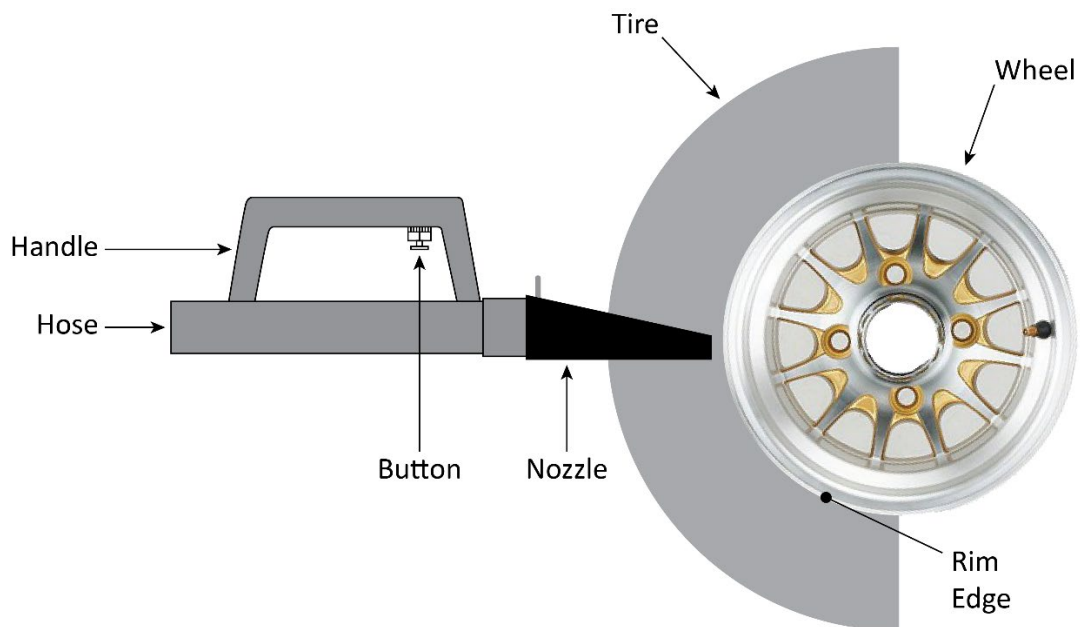

*Side view shown; nozzle must be held flat to use. Not to scale. Not all components shown.*

### **Bead Seating**

To seat a Tire's Beads, add air pressure until you hear a "pop", which indicates the Tire Beads have slipped over the Bead Humps into their Bead Seats.

Remember that a Tire has Beads on *both sides* of the Tire. The Beads must be seated on both sides. Bead Seating is not complete until the Beads are seated on both sides of the Tire.

**⚠ WARNING Do not exceed 40 psi to seat a Bead.**

The following procedure assumes the Tire's Beads have already been sealed. Do not try to seat the Beads until the Beads have been successfully sealed.

### **To Seat the Beads:**

1. Make sure the Air Chuck is clipped to the Valve Stem of the Tire.
2. Step back from the Tire.
3. Press and hold down the Inflation Foot Pedal.

---

Air begins flowing into the Tire.

After a few seconds, you should hear a “pop” as the Beads are seated.

Bead Seating usually requires 7 psi or above.

***Some Beads are harder to seat, but never exceed 40 psi to seat the Bead.***

If air pressure in the Tire rises to 40 psi but the Beads are still **not** seated, use the Pressure Relief Button to remove air down to about 5 psi and then try again. If you lower the psi too far, you may lose the Bead seal.

4. Release the Inflation Foot Pedal.
5. If the Beads do not seat on a second attempt, try the following:
  - Clean the rim’s bead.
  - Install a different Tire.
  - Generously re-lube the bead.
  - Ask your supervisor for instructions.
  - Remove all of the air from the Tire and start again (seal the Beads and then attempt to seat the Beads again)
6. If the amount of air pressure it takes to seat the Beads exceeds the manufacturer’s recommended psi for the Tire, use the Pressure Relief Button to remove air pressure from the Tire, bringing it back down to the recommended psi for the Tire.
7. When the Beads are properly seated, remove the Air Chuck from the Valve Stem and **reinstall the Valve Core**.



## Seat and Inflate the Tire

- **Bead Seating** is adding air pressure into the Tire until you hear a “pop”, which indicates the Beads (on both sides of the Tire) have slipped over the Bead Humps and against their Bead Seats. *Screw the Valve Core back in the valve stem once the Beads are seated.*
- If you have difficulty sealing the Beads (air escaping from between the Tire and the Rim), use the Turbo-Blast™ nozzle.
- **When Inflating a Tire.** Once the *second* stage of inflating a Tire (seating the Beads) is complete, install the Valve Core back in the valve stem.  
When sealing and seating the Beads, do not add air pressure above what the tire is rated to hold.
- **Inflation** adds air pressure to the Tire to achieve the manufacturer’s recommended pressure. **Do not stand over the Tire when inflating it.**

**CAUTION** Wear ear protection when inflating a Tire.

**WARNING** Do not exceed the maximum air pressure specified by the Tire manufacturer. This increases the chances that the Tire could explode, causing injury or even death to the Operator and bystanders.

Use the Pressure Gauge on the Tire Changer to monitor the air pressure in the Tire.

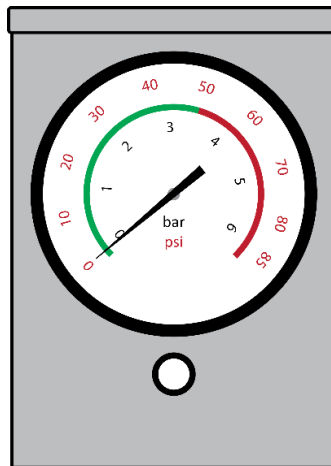

**DANGER** If you are inflating a Tire that requires more than 60 psi, you **must** use a **Tire Inflation Cage such as the RIC-4716** for safety purposes. If a Tire fails at high pressure, it can explode and cause severe injury or death to anyone near it. Using a Tire Inflation Cage helps reduce the danger.

Important inflation notes:

- Identify the **recommended** inflation pressure of the Tire (usually located on a sticker on the driver-side doorjamb) and the **maximum** inflation pressure of the Tire (usually located on the sidewall). When inflating, your goal is the recommended inflation pressure; do not exceed the maximum inflation pressure when inflating the Tire.
- Make sure the Tire is restrained for inflation: either *internally* clamped, held down by a Restraint Cone (R980DP only), or in a Tire Inflation Cage. Do not inflate a Tire if it is **externally** clamped; external clamping interferes with inflation.

---

The typical inflation pressure for automobile tires ranges from 30 to 45 psi, depending on factory recommendations, speed, vehicle use, and equipment. Light truck Tire inflation pressures may run a higher-pressure range.

**Do not exceed** the Tire manufacturer's **maximum** air pressure for a Tire. Written on sidewall.

The Tire Changer has an air pressure limiter that is set at the factory so that it does **not** exceed 60 psi. **Do not override the pressure limiter.**

**Inflate the Tire:**

1. Verify that both the upper and lower Beads are sealed and seated.
2. Verify that the Valve Core has been reinstalled tightly.
3. Make sure the Air Chuck is clipped to the Valve Stem of the Tire using the self-gripping clip.
4. Step back from the Tire.

 **DANGER** Do **not** stand over the Tire when inflating it. If the Tire explodes during inflation (which does not happen often, but does happen), you could be injured or killed if you are standing over the Tire when it explodes.

5. Press and hold down the Inflation Foot Pedal.  
Air begins flowing into the Tire.
6. Inflate the Tire to the manufacturer's **recommended** psi by monitoring the Pressure Gauge.
7. Release the Inflation Foot Pedal.
8. Remove the Air Chuck from the Valve Stem.
9. Take the Wheel off the Tire Changer.

---

# Maintenance

Make sure your Tire Changer is maintained on a regular basis.

 **WARNING** Disconnect the Tire Changer from power and the incoming air from the Air Source **before performing any Maintenance**. Take whatever steps are necessary to make sure the unit cannot be re-energized until Maintenance is over (such as Lockout/Tagout). Because the unit uses electrical and pneumatic energy, you could be electrocuted or even killed if the unit is powered back on during Maintenance.

The Tire Changer uses pneumatic and electrical energy; if your organization has **Lockout/Tagout policies**, make sure to implement them before performing maintenance on the Tire Changer.

 **DANGER** Always refer to the lubricant manufacturer's Material Safety Data Sheet (MSDS) for safe handling and disposal of chemicals.

## Regular Maintenance

- **Daily:** Make sure the unit is clean and dry.
- **Weekly:** Check all labels to make sure they are in place and legible. Contact BendPak Ranger if replacement labels are needed.
- **Weekly:** Check the water level of the Regulator/Filter. If the reservoir is one quarter (25%) or more filled with water, drain it. Refer to **Check the Water Level** for instructions.
- **Weekly:** Check the oil feed rate of the Oiler/Lubricator. It should be 1 to 2 drops per use of a pneumatic component. If it is above or below this level, you need to adjust it. Refer to **Check the Oil Feed Rate and Adding Oil** for instructions.
- **Weekly:** Check the amount of pneumatic oil in the Oiler/Lubricator reservoir. If it is under one half (50%) full, add oil. Refer to **Check the Oil Feed Rate and Adding Oil** for instructions.
- **Monthly:** Check the accuracy of the Inflation Gauge using a pressurized tire and a high-quality pressure gauge. Fix immediately if not working correctly.
- **Monthly:** Make sure all Anchor Bolts are tightened and secure, if used.
- **Monthly:** Make sure all components are in good operating condition. If you find a component that is **not** working correctly, take the Tire Changer out of service and refer to **Troubleshooting** for more information.
- **Twice a Year:** Have a licensed Electrician check the electronic components.
- **Yearly:** Take the Tire Changer out of service, disconnect the Power Cord from the power source, and then thoroughly check and clean all components.

 **WARNING:** Do not operate your Tire Changer if you find issues; instead, take the unit out of service, then contact your dealer, visit [www.bendpak.com/support/](http://www.bendpak.com/support/), or call **(805) 933-9970**, then follow the prompts.

---

## Check the Water Level

Water coming in from the Air Source is pulled out of the incoming air by the Regulator/Filter and dropped into the reservoir at the bottom.

This water needs to be drained periodically.

### To drain water from the Regulator/Filter reservoir:

1. Check the Water Sight Gauge to see how much water is currently in the reservoir.  
If the reservoir contains one quarter (25%) or more of water, drain to empty.
2. Disconnect the Air Source at the Air In connector.

**⚠ WARNING** Make sure to disconnect the Air Source and make sure it cannot be reconnected until you are done draining the water from the Regulator/Filter. If the Air Source is reconnected during the procedure, it could damage the Regulator/Filter, the Tire Changer, and possibly injure bystanders.

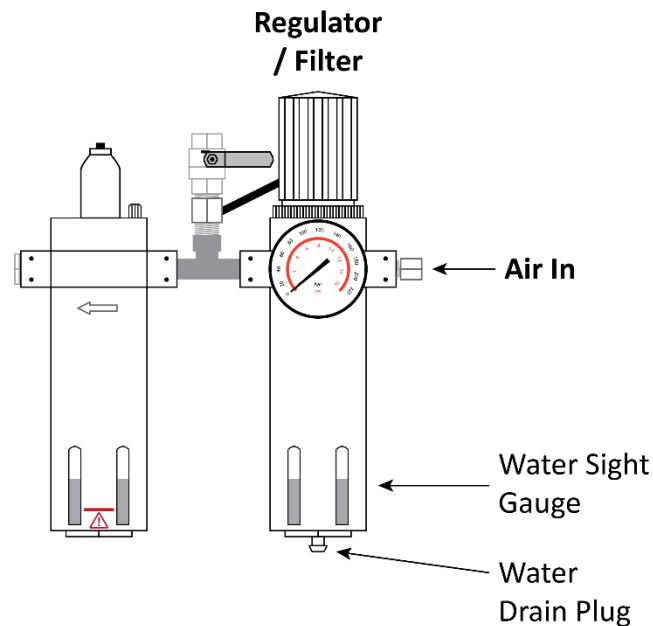

3. Press upwards on the Water Drain Plug at the bottom of the reservoir to drain the water out.
4. Release the Water Drain Plug.
5. Re-connect the Air Source.

---

## Check the Oil Feed Rate and Adding Oil

The built-in lubricator adds pneumatic oil to the incoming air. This ensures that all pneumatic components of the Tire Changer receive the necessary lubrication, which maintains operating performance, reduces wear, and extends service life.

It is very important to make sure the oil feed rate is correct, 1 or 2 drops of oil per use of pneumatic component (such as the Clamps Foot Pedal), and that there is enough pneumatic oil in the Oil Reservoir of the Oiler/Lubricator.

### To check the oil feed rate on the Oiler/Lubricator:

1. With the Air Source connected, press up or down on the Clamps Foot Pedal for several seconds, then release.

You do not need a Tire; you just need to use a pneumatic tool.

2. Watch the Sight Glass to see how much pneumatic oil comes out each time you press up or down on the Clamps Foot Pedal.

Your goal is for 1 or 2 drops out each time.

3. If there are **fewer** than 1 or 2 drops, turn the Adjustment Screw counterclockwise (using a small flat-head screwdriver), then press the Clamps Foot Pedal again to check the output.
4. If there are **more** than 1 or 2 drops, turn the Adjustment Screw clockwise, then press the Clamps Foot Pedal again to check the output.
5. If there are 1 or 2 drops, stop turning the Adjustment Screw.

### To add pneumatic oil to the Oiler/Lubricator:

1. Check the Oil Sight Gauge to see how much pneumatic oil is currently in the reservoir.

If the reservoir is less than one half (50%) filled with pneumatic oil, add oil.

2. Disconnect the Air Source at the Air In connector.
3. Turn the Oil Fill Cap on the top of the Oil Reservoir to remove.
4. Add SAE 10W Air Tool Oil or generic pneumatic oil to the reservoir.
5. Reinstall the Oil Fill Cap back.
6. Reconnect the Air Source.

# Troubleshooting

**⚠ WARNING:** Disconnect the Power Cord from power and the incoming from the Air Source **before performing any maintenance**. Take whatever steps are necessary to make sure the unit cannot be re-energized while maintenance is being performed on it (such as Lockout/Tagout). The unit uses pneumatic and electrical energy; if your organization has Lockout/Tagout policies, make sure to implement them before troubleshooting the Tire Changer.

<b>Issue</b>	<b>Action to Take</b>
The Turntable does not move when depressing the Turntable Foot Pedal.	Make sure the unit is receiving power.
The unit is not receiving power.	Have a licensed Electrician check the electrical path from the supplied cord to the power source. If any issues are found, have them repaired. Refer to <b>Wiring Information</b> for additional information.
No air exits the Air Hose when depressing the Inflate Foot Pedal.	Make sure the unit is correctly connected to a working Air Source.
It is difficult to secure Tires when clamping externally.	Use the Restraint Cone to press the Tire down so the Clamps correctly grab the Rim of the Wheel.
The Inflation Gauge is not working correctly.	Check the accuracy of the Inflation Gauge with a professional gauge. Fix immediately if the Inflation Gauge is not working correctly.
The Assist Arms move up and down slowly or make odd noises when moving.	Grease the Assist Tower Post, it has run out. Refer to <b>Grease the Assist Tower Post</b> for more information.

If you continue to have problems with your Tire Changer, visit [www.bendpak.com/support/](http://www.bendpak.com/support/) or call **BendPak Ranger at (805) 933-9970**, then follow the prompts.

# Wiring Information

The R980DP-L Tire Changer is delivered with a plug and cord wired for a standard 110VAC, 60 Hz, 20 amp circuit.

The R980DP Tire Changer is delivered with a Power Cord that is wired inside the unit on one end and with three exposed wires on the other end. The three exposed wires must be hard-wired to the facility's power system or connected to a 220 VAC, 30A, 2-Pole, 3-Wire, NEMA rated plug (which is then connected to a properly grounded 220VAC power outlet). The electrical supply to the R980 must be protected by an appropriate fuse or circuit breaker.

**⚠ WARNING:** All electrical work, **must be accomplished by a licensed Electrician** in accordance with all applicable national and local electrical codes. Damage to the unit caused by improper electrical installation voids your warranty.

The Tire Changer is **not** delivered with a 220 VAC **Plug**; your electrician must supply one.

The colors of the three exposed wires are Brown, Blue, and Green/Yellow, the European color code.

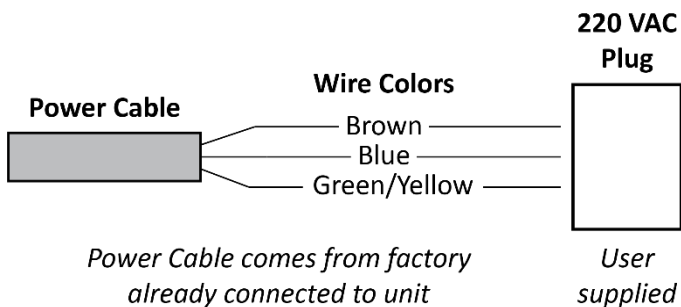

**Important:** To connect the three exposed wires to an appropriate Plug or to hard wire them, have your Electrician follow the electrical codes for the country in which you are using the unit and any local electrical codes.

For example, if you are using the unit in the United States, the color codes on the wiring delivered with the Tire Changer correspond to:

- **Brown:** Live
- **Blue:** Live
- **Green/Yellow:** Ground

If you were using the unit in a European country, the color codes on the wiring delivered with the Tire Changer correspond to:

- **Brown:** Live
- **Blue:** Neutral
- **Green/Yellow:** Ground

Information about color code conventions in other regions and countries is available online. Make sure your Electrician installs the Plug in accordance with all applicable local electrical codes.

# Labels



PN 5906090



PN 5906092



PN 5905860

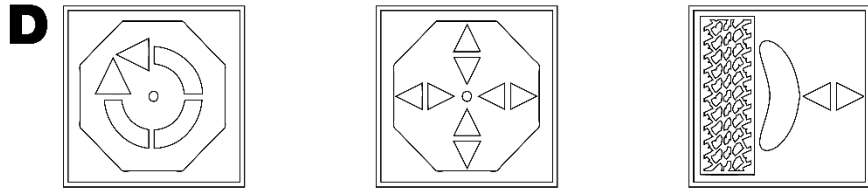

R980AT\_Foot\_Pedal\_Decals.pdf:



Tire\_Changer\_Warning\_Decal.pdf:



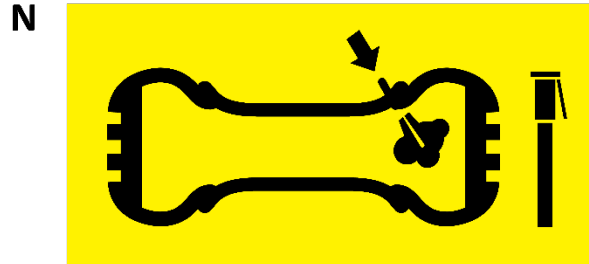

- F - RNGR Electric Warning
- G - RNGR Bead Breaker Warning
- H - RNGR Hold Down Warning
- I - RNGR Pinch Plates Warning
- J - RNGR Pinch Warning
- K - RNGR Blast Warning
- L - RNGR Turn Table Warning
- M- RNGR Cross Tube Labels
- N- RNGR Inflation Pedal Label

O

**⚠ IMPORTANT - PLEASE READ**

**FILTER / REGULATOR LUBRICATOR INSTRUCTIONS**

**WARNING!**

Failure to regularly drain water and maintain proper oil level and oil feed rate will damage internal pneumatic components and void product warranty.

The inline lubricator helps ensure that all pneumatic components inside this machine receive the required lubrication to maintain operating performance, reduce wear and prolong service life. It is designed to automatically provide the correct amount of oil feed rate required within the pneumatic system delivering a constant ratio of oil to CFM.

The filter/regulator is designed to remove airborne solid and liquid contaminants which may plug small orifices and hinder performance or cause excessive wear and premature equipment failure. The regulator provides controlled and consistent air pressure as required. NOTE: This model requires 15-25 CFM air source with a safe operating air pressure of 140-165 PSI for optimum machine performance.

**Water Separator / Lubricator Maintenance**

- Check oil and water levels regularly and perform these maintenance items weekly.
- Observe the water sight gauge on the water separator/filter unit. If water is observed, drain by pressing upwards on the drain plug at the bottom of the reservoir.
- Observe the sight glass and adjust the oil feed rate by turning the small adjustment screw on the top of the glass bowl so that 2-3 drops of oil drip through the site glass for each operation of the bead loosener pedal.

**Adding Oil to Oiler / Lubricator**

If oil level is low, add oil as follows:

1. IMPORTANT - First disconnect air source from machine.
2. Remove oil reservoir by unthreading reservoir from head of oiler/lubricator.
3. Add oil as necessary.

4. Replace reservoir making sure rubber O-ring is seated properly and reservoir is firmly tightened hand-tight.

**Regulator / Filter**

**Oiler / Lubricator**

P/N 5900408

P

**⚠ DANGER**

**GROUND ALL ELECTRICAL EQUIPMENT**

Establish and maintain proper earth ground. Voltage or ground hazard sufficient to cause shock, burn or death.

This machine is wired for **110 volts** single phase ONLY. Improper wiring will cause damage and void warranty.

**⚠ DANGER**

**GROUND ALL ELECTRICAL EQUIPMENT**

Establish and maintain proper earth ground. Voltage or ground hazard sufficient to cause shock, burn or death.

This machine is wired for **110 volts** single phase ONLY. Improper wiring will cause damage and void warranty.

P/N 5900365

Q

**⚠ DANGER**

**GROUND ALL ELECTRICAL EQUIPMENT**

Establish and maintain proper earth ground. Voltage or ground hazard sufficient to cause shock, burn or death.

This machine is wired for **208-240 volts** single phase ONLY. Improper wiring will cause damage and void warranty.

**⚠ DANGER**

**GROUND ALL ELECTRICAL EQUIPMENT**

Establish and maintain proper earth ground. Voltage or ground hazard sufficient to cause shock, burn or death.

This machine is wired for **208-240 volts** single phase ONLY. Improper wiring will cause damage and void warranty.

P/N 5900456

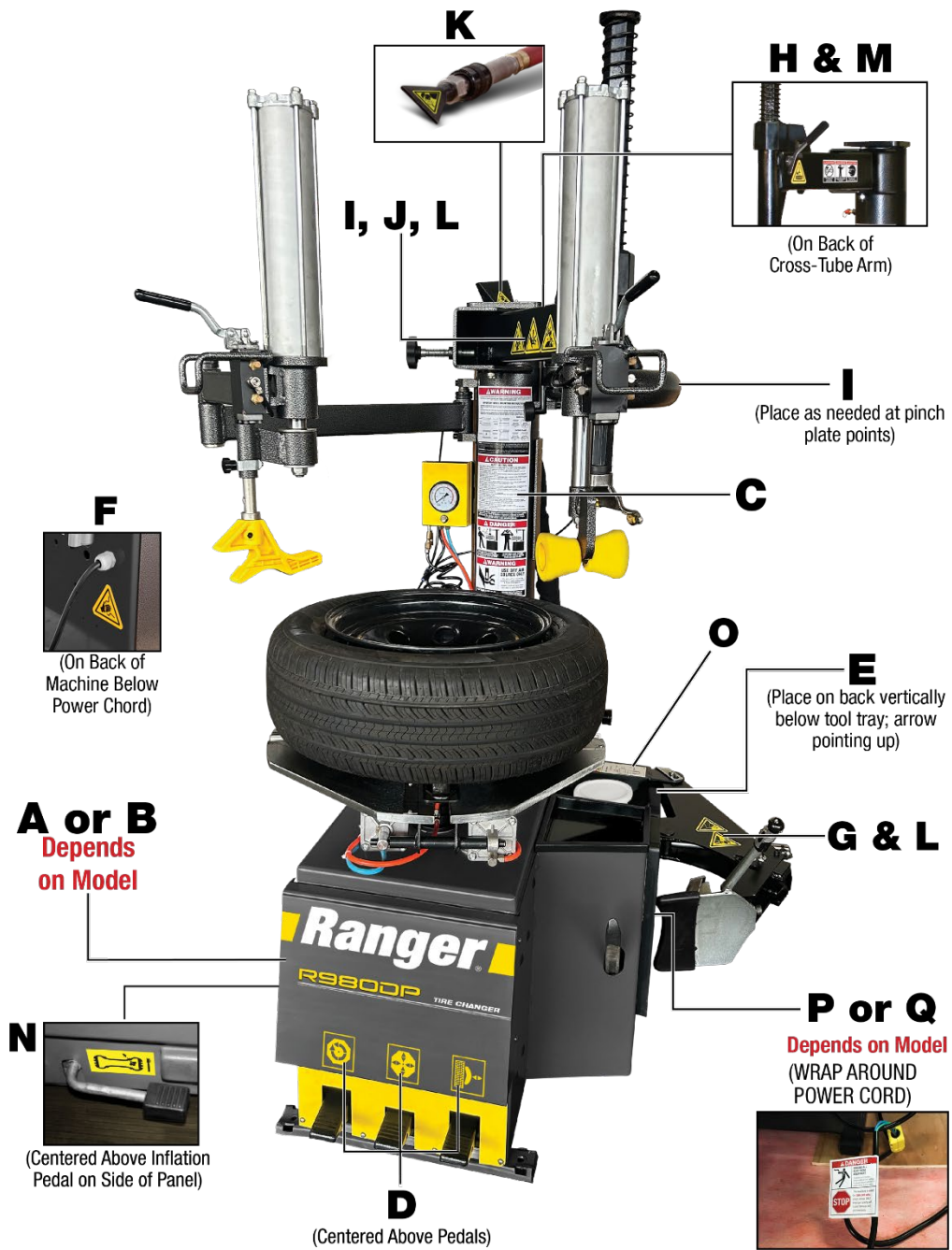

# Parts

## Cabinet

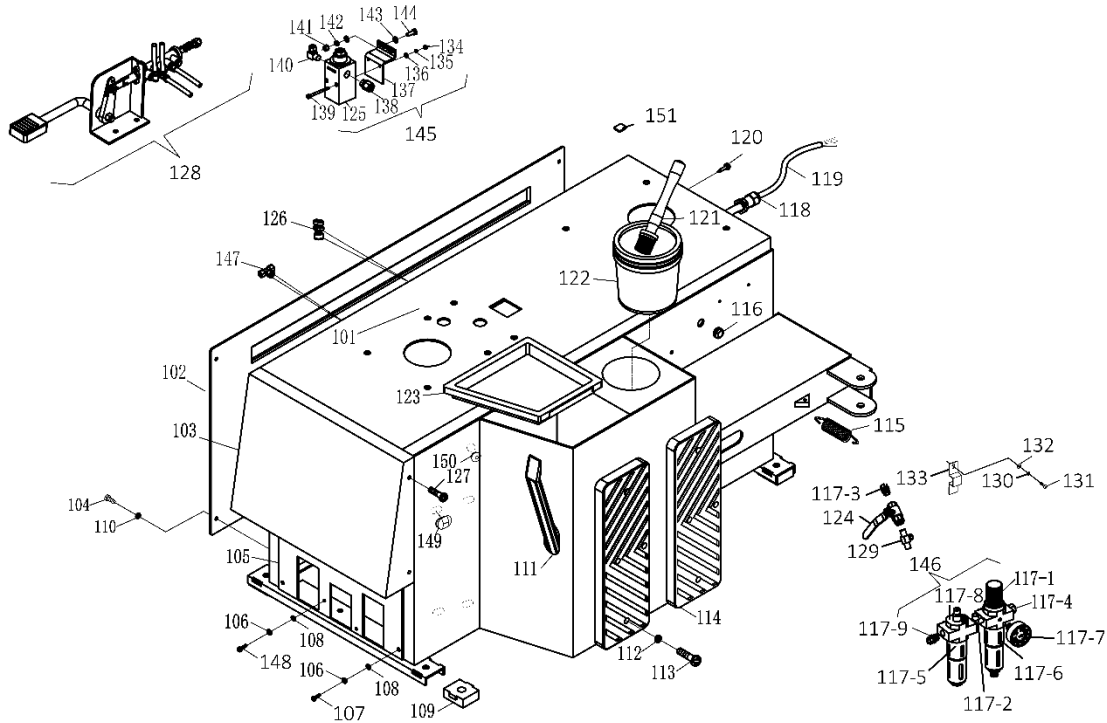

Number	Part Number	Description
101		Container weldment
102	5327673	Side Cover
103		Container front face weldment
104		Large flat head screw with cross groove
105		Chassis front board
106		Washer, M6 x 12mm Flat
107	5328257	Socket Head Cap Screw M6X12
108	5400913	Washer; M6 x 12 mm Flat
109	5327307	Plastic Foot Pad
110	5400913	Washer; M6 flat
111	5400110	Pry Bar
112		Washer; M6 Flat
113		Cross recessed round head screw M6X25
114	5327614	Wheel Support Pad
115	5327309	Bead Breaker Return Spring
116		Cable Holder
117-1	5327846	Yellow Air Regulator/Dryer
117-2	5327806	Fitting; 1/4 x 1/4 Tee
117-3	5400923	Fitting 1/4"
117-4	5327559	Tower Straight In 1/4"

117-5	5327684	Oil Cup
117-6	5327685	Filter Cup
117-7		Air Pressure Gauge
117-8	5327847	Yellow Air Oiler
117-9	5400923	Fitting 1/4" 12mm
118		Rubber cord grip
119		Power Cord
120	5327530	STS M5.5X25
121	5400121	Soap Brush
122	5400120	Soap Bucket
123	5327672	Tool Tray
124	5327671	1/4" <b>Ball Valve</b>
125		Full flow inflation regulator
126	5327558	Fitting 8mm
127		Cross recessed round head screw M6X10
128	5328139	Inflation Foot Pedal Assy
129	<b>5327824</b>	Tee Union 1/4" X-08X1/4"
130		Washer, Spring 4mm
131		Cross recessed round head screw M4X12
132		Washer, Flat 4mm
133	5328278	Air/Oil regulator support
134		Nut M4
135		Washer, Spring 4mm
136		Washer, Flat 4mm
137		Full flow inflation kit bracket
138	5327560	Fitting 1/4"
139		Socket head cap screw M4X50
140		Fitting 90° 1/4" <b>8mm</b>
141		Nut M6
142		Washer, Spring 6mm
143		Washer, Flat 6mm
144		Hexagon headed bolt M6X20
145	5327785	Pneumatic Valve
146	5328220	Air/Oil Regulator Assy
147		Tee joint union, 8mm
148	5328139	Cross recessed round head screw M6X20
149		Plug
150		Round Board
151		Plug

# Main Tower

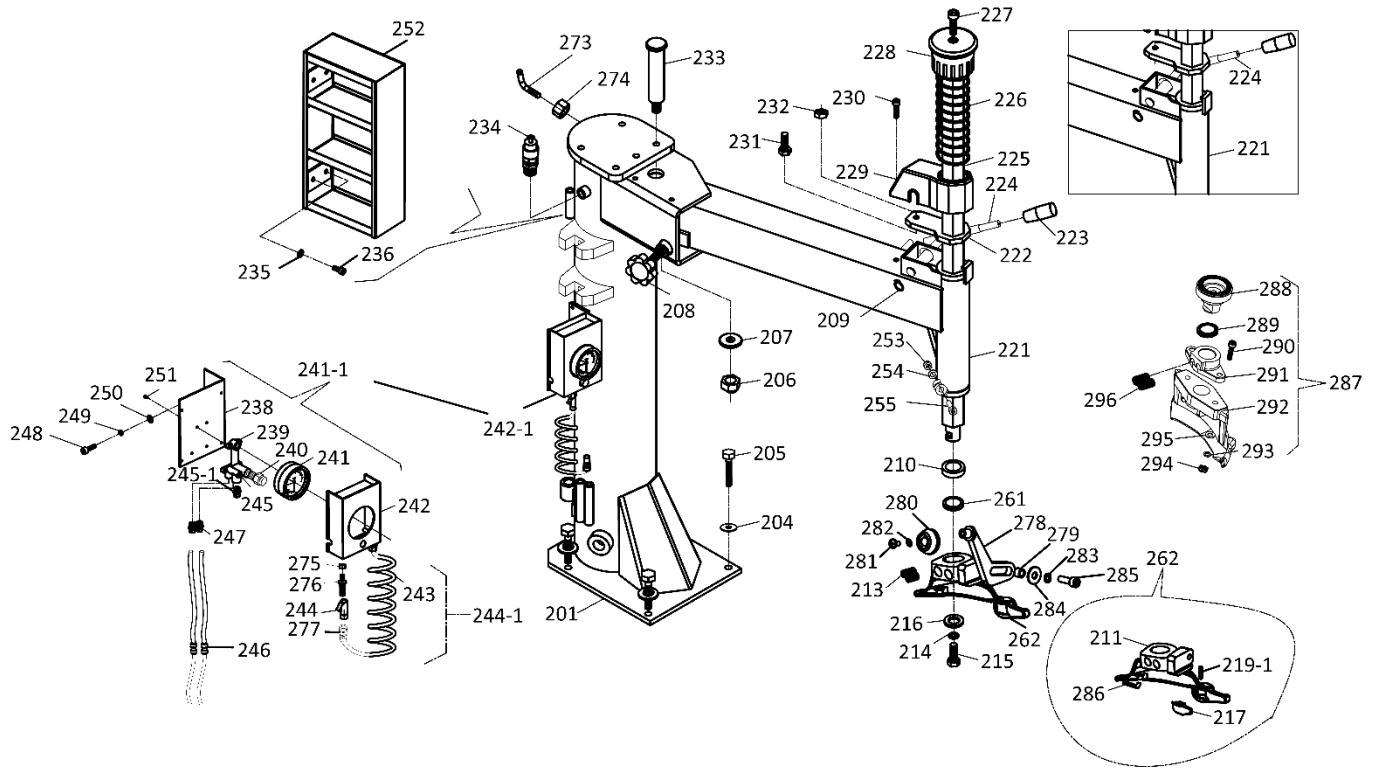

Number	Part Number	Description
201		Tower unit weldment
204		Washer; M12 x 24
205		Hexagon headed bolt M12 x 60
206		Locknut M16
207		Lock pad
208	5401222	Swing Arm Adjustment Screw with Knob
209	5404141	M18 Snap Ring
210	5327310	Mount / demount head $\phi 46 \times 34 \times 12$
211	5328198	Metal Duckhead
213	5327468	M12 x 16 Duckhead Set Screw;
214		Washer $\phi 10$
215	5327729	Hexagon headed bolt M10 x 30
216	5327436	Duckhead Insert
217	5327636	Roller Insert;
219-1		Screw
221	5328232	Swing arm unit weldment A
222	5327667	Locking Plate
223	5327617	Locking Handle Knob
224	5327618	Locking Handle
225	5327619	Vertical Shaft
226	5400237	Hex Shaft Spring; B & I Models
227	5400942	Socket head cap screw M10 x 25
228	5400240	Hex shaft cap

229	5327620	Hex Shaft Lock Cover
230	5400959	Socket head cap screw M6 x 30
231		Hexagon headed bolt M10 x 25
232		Thin nut M10
233	5327359	Swing arm pivot pin
234	5327449	Pressure Release Valve; I Models
235	5400913	Washer; M6 flat
236	5400966	Socket head cap screw M6 x 16
238	5327414	Inflator Assy Base; I Models
239		Tire Inflator Relief Valve; I Models
240	5327055	Air Release Valve; I Models
241	5327769	Inflating gauge
241-1	5327463	Inflation System Assy
242	5327051	Inflation System Plastic Cover; I Models
242-1	5327463	Tire Inflator Box Assy
243	5327484	Coiled Hose;
244	5327538	Air Chuck
244	5327538	Air Chuck; I Models
244-1	5327130	Inflation Hose Assy; I Models
245		Block G1/8"
245-1	5327553	Air Chuck; I Models G1/4"-G1/8"
246	5327558	Fitting 8 mm Y
247	5328122	Fitting G1/8" $\phi$ 8 Straight
248		SHCS M6 x 10
249		Washer $\phi$ 6
250	5400913	Washer; $\phi$ 6 flat
251		Cross recessed round head screw M3 x 10
252	5327173	Toolbox
253		Nut M8
254		Washer M8
255		SHCS M8 x 35
261		Duckhead adjust pad
262		Mount/demount head assy. (Duck Head)
273	5327472	Turbo blast hook
274	5327884	Nut M8
275		Nut M6
276		Inflation hose plug
277		Fitting G1/8" $\phi$ 8
278		Tire pressure arm
279		Arm axes
280		Plastic BB roller
281		Cross recessed round head screw M6 x 10
282		Washer $\phi$ 6 x 1.6
283		Washer $\phi$ 8
284		Washer $\phi$ 8 x 2
285		SHCS M8 x 25
286	5328119	Duckhead Insert (A)
287	5327880	Plastic components of bird head
288	5327854	Quick change head fixed set of bird
289		Pad

290		SHCS M8 x 40
291	5328289	Plastic head flange
292	5150523	Plastic head Duckhead
293	5545202	Washer; M8 x 15 LW
294	5327884	Nut M8
295	5402104	Washer; M8 x 16 flat
296		Hexagon inner flat end set screw

## Turntable

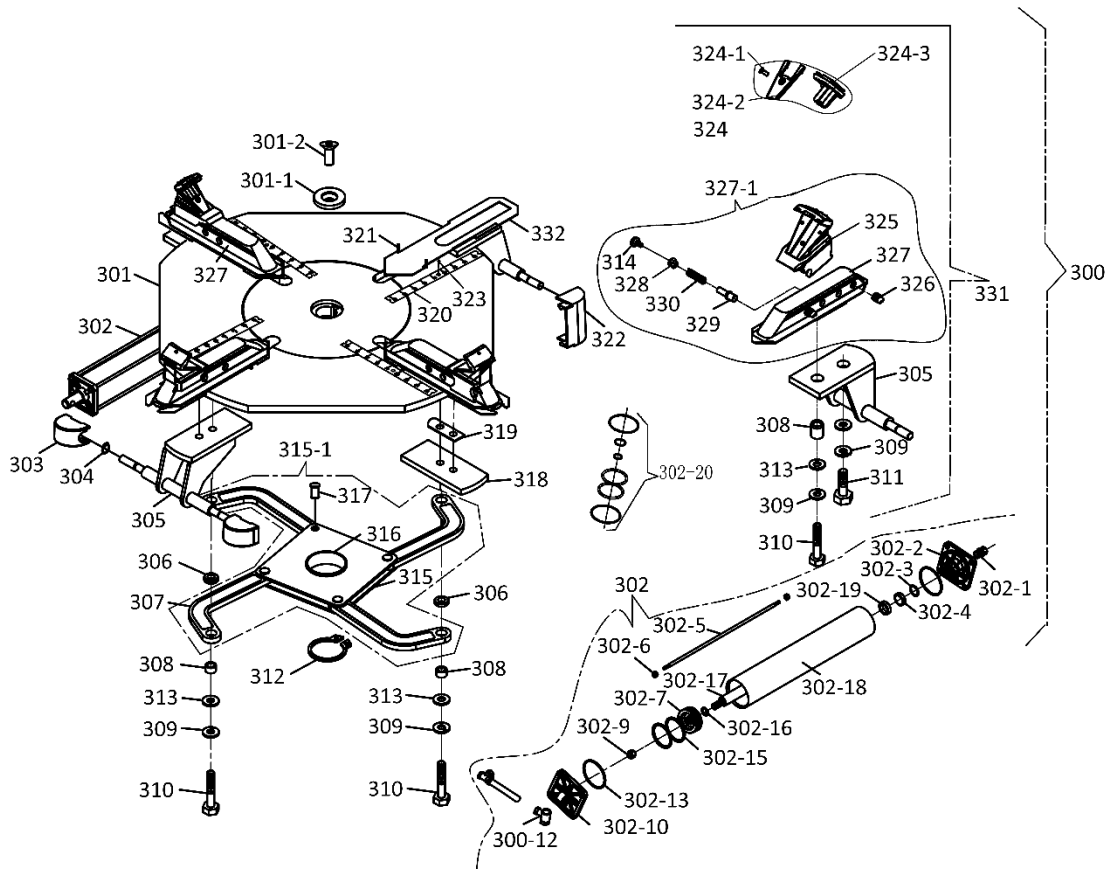

Number	Part Number	Description
300		Turntable plate assy
301	5327713	Turntable plate welding
301-1	5327263	Turntable plate assy
302	5327300	Jaw clamp cylinder
302-1		Fitting; G1/8 8 mm
302-2	5327365	Small Front Cylinder Cover; I Models
302-3	5327487	O-Ring 25 x 3.1; I Models
302-4	5327510	Jaw Clamp Cylinder Wear Strip; I Models
302-5	5401421	HHB M8
302-6		Locknut M8
302-7	5327366	Small Cylinder Piston; I Models



302-9		Locknut M12
302-10	5327364	Small Rear Cylinder Cover; I Models
302-12	5400459	Union G1/8" elbow
302-13	5327488	O-Ring 75 x 2.65
302-15	5327489	O-ring 75 x 5.7
302-16	5327486	O-ring 16 x 2.4; I Models
302-17		Jaw clamp cylinder rod
302-18	5327406	Jaw clamp cylinder body
302-19	5327494	Y-Ring 32 x 20 x 6
302-20		Seal ring
303	5327305	Small cylinder cover
304	5400905	Snap ring 12 mm
305	5327471	Slide Guide
306	5327735	Square Turntable Slide Rod Pad
307	5327041	Square Turntable Link
308	5327500	Square Turntable shaft sleeve
309		Washer 12 mm spring
310		HHB M12 x 50
311		HHB M12 x 25
312	5401416	Snap ring 65 mm
313		Washer; M12 x 24
314	5327263	Jaw Clamp Locking Pin
315	5327402	Square Turntable main board
315-1	5327450	Square Turntable assy
316	5327495	Square Turntable Spacer
317	5327521	Square Turntable Press Pin
318	5327542	Slave Slide Guide
319	5327461	Slide Shim Adjustment
320		Turntable Ruler
321		Split pin
322	5327306	Large cylinder cover
323		Turntable Ruler Screw; M4 x 6
324	5327081	Jaw Clamp Cover Set; I Models (quantity 4)
324	5328234	Jaw Clamp Cover Set; I Models (quantity 4)
324-1	5328310	Stainless steel hex socket countersunk head screws M4 x 10
324-2	5328312	Plastic Mattress for jaw clamp
324-3		Rubber blanket for jaw clamp
325	5327404	Jaw Clamp; R23/26/980 (I)
325	5328311	Jaw Clamp; I Models Rev-A W/Rubber Insert
326	5328400	special screw M10 x 1
327	5327405	Jaw Clamp Support; R23/26/980 (I)
327	5328306	Jaw Clamp Support; R76/980
327-1		Jaw Clamp Support assy
328	5327630	Jaw Clamp Inner Adjustment Knob
329	5327621	Jaw Clamp Inner Adjustment Pin
330	5327662	Jaw Clamp Pin Spring
331	5327623	Jaw Clamp Locking Pin
331	5327623	Jaw Clamp Locking Pin
332	5328328	Boat gasket
342		Turntable assy (B) cylinder bracket assembly

# Bead Breaker

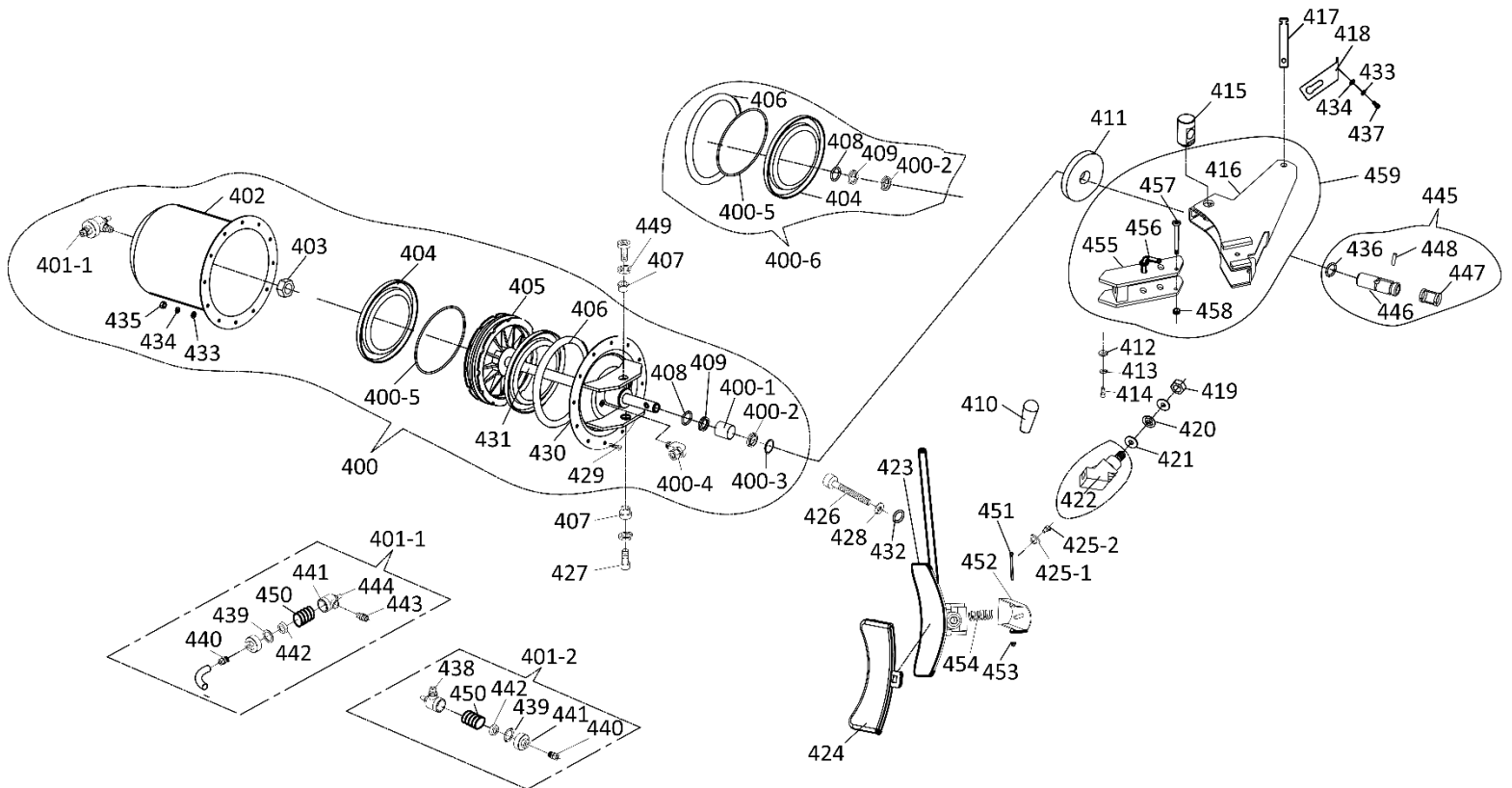

Number	Part Number	Description
400	5327664	Bead Breaker Cylinder Assy
400-1		Oil Bearing $\phi 23\text{mm} \times \phi 20\text{mm} \times 20\text{mm}$
400-2		Seal ring $\phi 30\text{mm} \times 20\text{mm} \times 7\text{mm}$
400-3		Elastic Ring $\phi 32\text{mm}$
400-4	5327873	Fitting; 90° G1/4" $\phi 10\text{mm}$
400-5		Guide Ring
400-6	5327772	Large cylinder seal assortment
401-1	5327459	12 mm x 1/4" BB Flow Control Valve
401-2	5327815	12 mm x 12 mm BB Flow Control Valve
402		Cylinder liner
403		Nut M18 x 1.5 – (Thin threaded)
404	5327682	Y-Ring 200mm x 12mm x 6mm
405	5327413	BB Cylinder Piston
406	5327537	O-Ring; 193mm x 5.7mm
407	5328078	Eccentric Bushing
408	5327487	O-Ring, 25mm x 3.1mm
409	5327493	Y-Ring $\phi 25\text{mm}$
410	5327634	Bead Breaker Blade Handle
411	5327177	Rubber Disc
412	5545202	Washer M8 x 15 LW
413	5402104	Washer $\phi 8\text{mm}$
414	5400966	Socket Head Cap Screw M8 x 16mm
415	5327367	BB Arm Cylinder Pin

416		Bead Breaker Arm
417		Bead Breaker Arm Shaft
418		Bead Breaker arm shaft Baffle
419		Locknut M16
420		Pad (wave) $\phi$ 16mm
421		Washer $\phi$ 16mm
422	5328852	Bead Breaker Knuckle
423	5327768	Bead Breaker Blade
424	5327082	Bead Breaker Blade Cover
425-1	5328083	Washer/Bushing
425-2	(incl. -1, -2)	Hex Head Bolt
426	5327609	Socket Head Cap Screw M14 x 95-12.9
427	5327981	Socket Head Cap Screw M14 x 36
428		Washer M14
429	5400966	Hexagon Headed Bolt M8X16
430	5401520	Flange Unit Weldment
431	5327677	Cylinder Rod
432		Spring Pad M14
433		Washer, M6 Flat
434		Washer
435		Nut M8
436	5327487	O Ring 25mm x 3.1mm
437	5327730	Cross Recessed Round Head Screw
438	5327732	Fitting G 1/4" 12mm
439		Leather Cushion
440	5327732	Fitting G 1/4" 12mm
441		Exhaust Valve
442		Exhaust Valve metal cup
443		Fitting G 1/4-G 1/4"
444	5327561	Silencer 1/4" NPT
445	5327982	Blade Adjustment component kit
446	5327982	Blade Adjustment component kit
447	5327982	Fitting; G1/4" 12 mm; w/ Blade Adjustment component kit
448	5327982	Blade Adjustment component kit
449		Washer M14
450		Metal quick exhaust valve
451		SHCS M8X85
452		Bracket
453		Nut M8
454		Pressure Spring
455		Shovel arm slide assembly
456		BB Blade Adjustment Rod
457		Pin
458		BB Blade Adjustment Pin; Nut
459		BB Blade Adjustment Bracket assembly

# Gearing

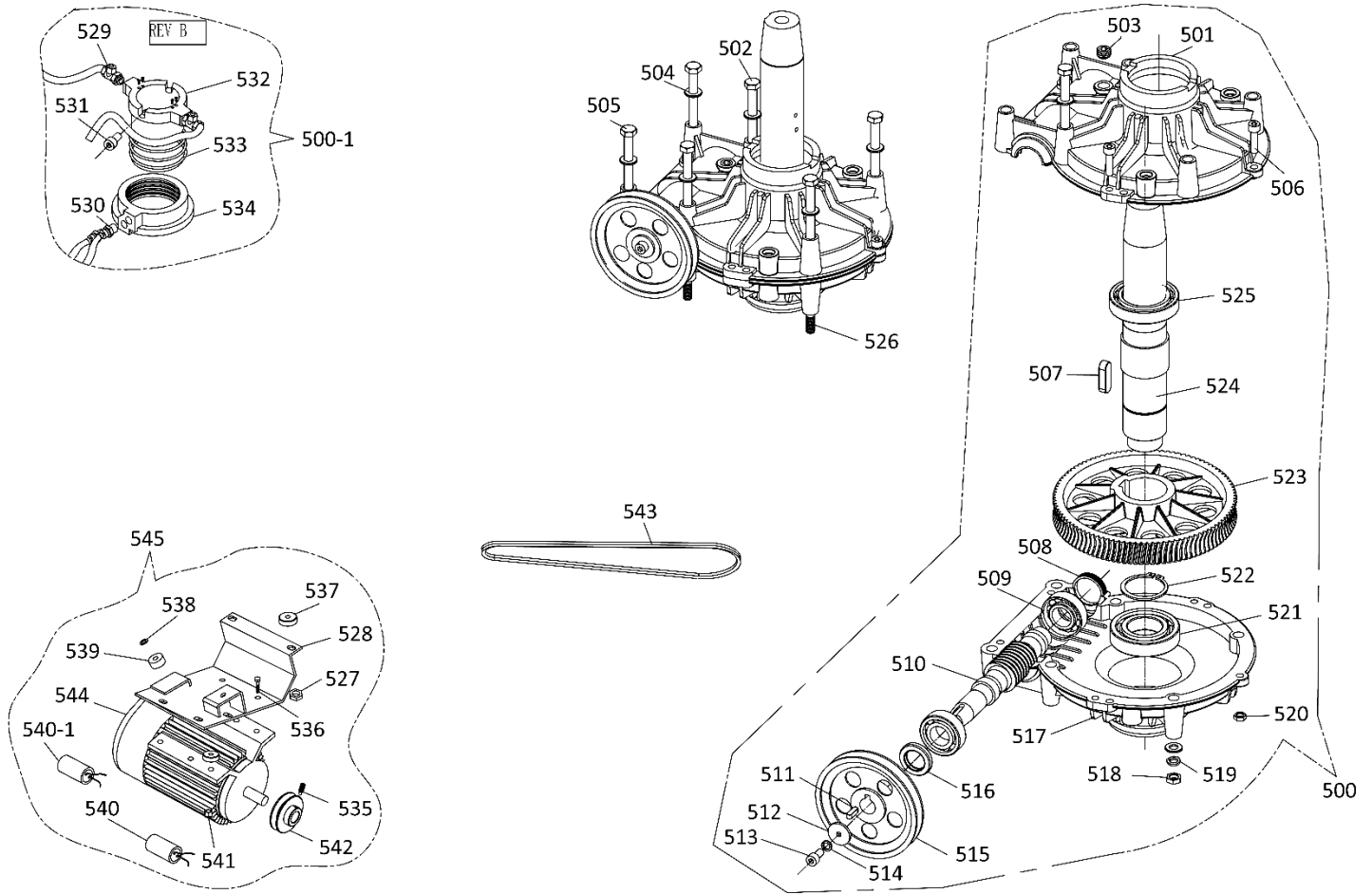

Number	Part Number	Description
500	5327479	Gearbox Assy
500-1	5327176	Gearbox front flange
501	5327520	Gearbox front flange Assy
502		Hexagon headed bolt
503		Oil plug
504		Washer $\phi 10\text{mm}$
505		Hexagon headed bolt M10 x 180
506		Socket head cap screw M8 x 30
507		Key; 12mm x 8mm x 35mm
508		Oil Block; 45mm x 8mm
509		Cone roller bearing
510		Drive Gear
511		Key 6mm x 6mm x 20mm
512		Gear stud pad
513		Socket head cap screw M8 x 16mm
514		Washer $\phi 8\text{mm}$
515	5327976	Gear Box Pulley
516		Oil seal $\phi 45\text{mm} \times 25\text{mm} \times 10\text{mm}$

517		Gearbox back flange
518		Nut M10
519		Washer $\phi$ 10
520		Nut M8
521		Bearing
522		Snap-Ring (Seeger ring $\phi$ 50mm)
523		Helical gear m2 (Al)
524		Splined shaft
525		Bearing
526		Hexagon headed bolt M10 x 170mm
527		Nut M10
528		Motor Base Unit Weldment
529		Fitting; $\phi$ 8mm- $\phi$ 8mm-G1/8"
530		Fitting; G1/8" $\phi$ 8mm
531		Inner hexangular set screw M6 x 20
532		Rotary Joint Block Inner Piece
533		O-ring $\phi$ 60mm x 2.75mm
534		Rotary Joint Block Outer Piece
535		Hexagon socket set screw M8 x 16mm
536		Hexagon headed bolt M8 x 40mm
537		Electrical line
538		Washer 10mm
539		Transmission Bracket Bushing
540	5327819	Capacitor 450 VAC 50 MF
540-1		Start capacitor
541		Locknut M8
542	5327369	Motor Pulley
543	5327656	V Belt
544	5327429	3HP Electric Motor
545		Motor with support Y

# Pedals

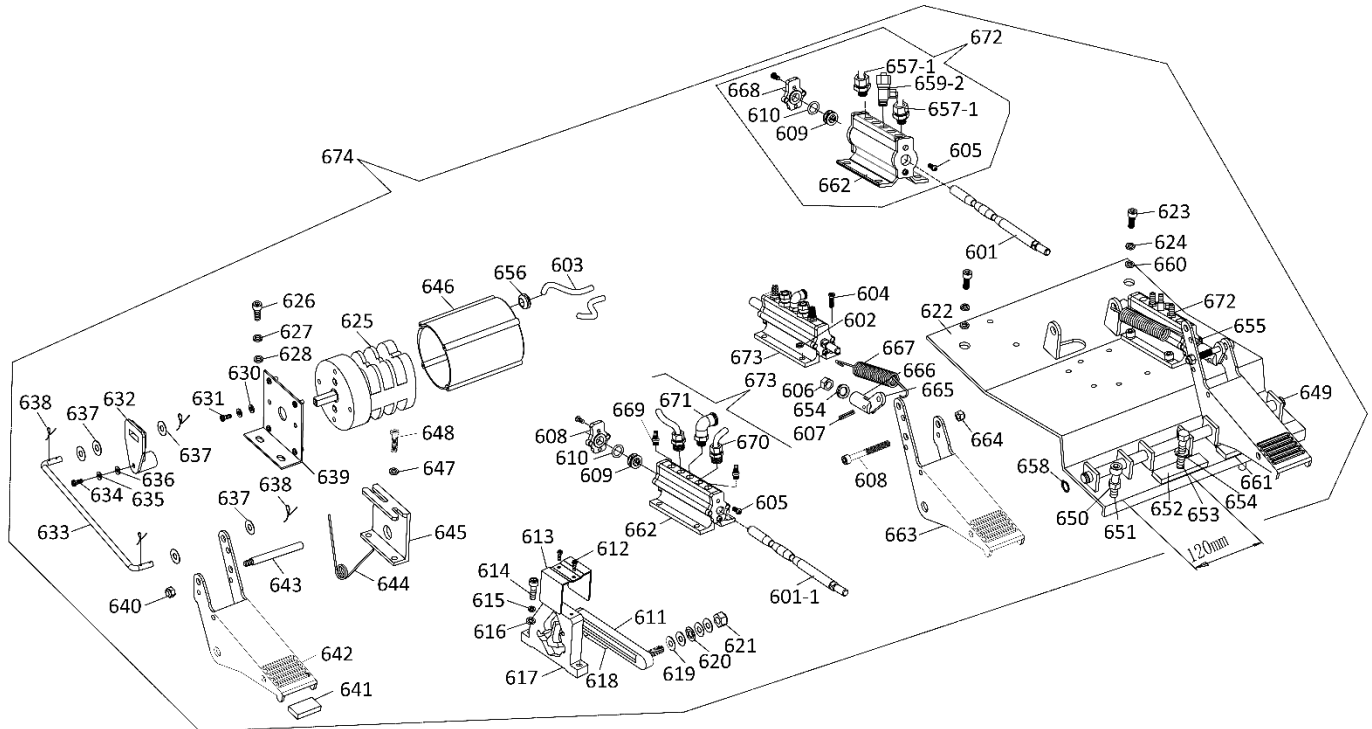

Number	Part Number	Description
601		Air valve shaft
601-1	5327531	Tilt tower air valve shaft I Models
602		Washer; $\phi 6$ spring
603		Power Line
604		Cross recessed round head screw M6 x 12
605		Cross recessed round head screw M4 x 10
606		Nut M8
607		Spring pin M4 x 18 $\phi 4$ x 18
608		Socket head cap screw, M6 x 55mm
609	5327482	Air Valve O-Ring Spacer
610	5327536	O-Ring; 17mm x 4mm
611	5327049	Foot Pedal Cam Link
612		Cross recessed tapping screws M3 x 10mm
613	5327412	Foot Pedal Cam Cover
614		Socket head cap screw M6 x 30
615		Washer; M6 x 12mm Flat
616	5400913	Washer; M6 flat
617	5327047	Foot Pedal Cam
618	5327048	Cam Arc Washer
619		Washer $\phi 8$ mm
620		Pad
621		Locknut M8
622		Foot pedal control board unit; weldment
623		Socket head cap screw M8 x 20mm
624		Washer $\phi 8$ mm
625	5400331	Turntable Direction Switch

626		Socket head cap screw M6 x 16mm
627		Washer; M6 x 12 mm Flat
628	5400913	Washer; M6 flat
629		Washer $\phi$ 5mm flat
630		Washer $\phi$ 5mm spring
631		Cross recessed round head screw M5 x 16
632	5400324	Turntable Direction Switch Cam
633	5327038	Directional Switch Cam Linkage
634		Cross recessed round head screw M4 x 16mm
635		Washer $\phi$ 4mm spring
636		Washer $\phi$ 4mm flat
637		Washer $\phi$ 6mm
638		Cotter pin $\phi$ 3.2mm x 25mm
639		Directional Switch Bracket
640		Locknut M6
641	5327345	Foot Pedal Rubber Insert
642	5327032	Foot Pedal (Right)
643		Foot Pedal Limit Rod
644	5327035	Foot Pedal Torsion Spring
645	5327409	Torsion Spring Bracket
646		Directional Switch Cover
647		Washer; M6 x 12 mm Flat
648		Cross recessed round head screw M6 x 12mm
649	5327408	Foot pedal shaft
650		Nut M8
651		Socket head cap screw M8 x 55mm
652		Control system adjustment pad (thin)
653		Hexagon headed bolt M8 x 16mm
654		Spring pad $\phi$ 8mm
655		Big cylinder locating coat
656		Cable holder $\phi$ 12mm
657-1	5400923	Fitting G1/4" $\phi$ 12mm Straight
658		Snap Ring (Seeger Ring) $\phi$ 12mm
659-2		Tee joint union $\phi$ 10mm- $\phi$ 8mm-G1/4"
660		Washer $\phi$ 8mm flat
661		Control system adjust pad (thick)
662		Air Valve
663	5327033	Foot pedal (left)
664		Locknut M6
665		Air Valve Connecting Link
666		Foot Pedal Link
667	5327034	Foot Pedal Return Spring
668	5327499	Air Valve End Cap
669	5327562	Silencer G1/4"
670	5327745	Silencer G1/4"
671	5400933	Silencer G1/4"
672		BB cylinder air valve assembly
673		Cylinder air valve assembly
674	5327863	Foot pedal assembly

# Turbo Blaster

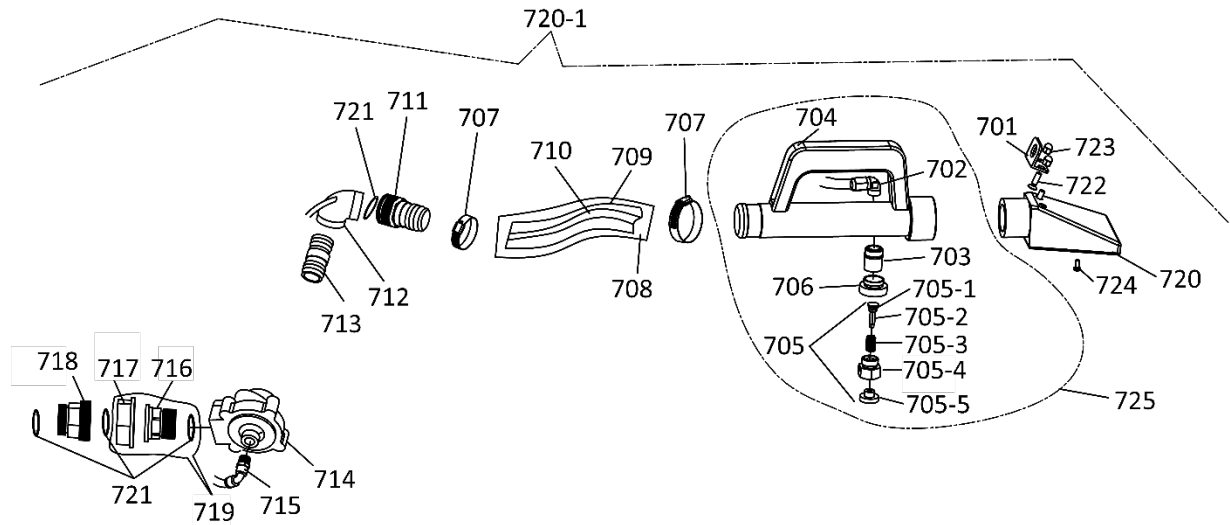

Number	Part Number	Description
702		Locknut elbow
703		Union
704		Turbo blast handle
705		Vent valve
705-1		O-ring
705-2		Piston
705-3		Spring
705-4		Valve
705-5		Button
706		Clamp nut
707		White steel buckle
708	5328444	Nylon sleeve
709		PVC steel wire tube
710		PU straight pipe
711	5328442	Turbo Blast Joint
721		O-ring $\phi 28\text{mm} \times 3.55\text{mm}$
712	5400824	Elbow
713	5328439	O-ring $\phi 40\text{mm} \times 3.55\text{mm}$
714	5328446	Union
715		Turbo blast valve
716	5328494	Elbow
717		Movable joint
718		Movable joint sleeve
719		Movable joint
720-1		Turbo Blast Complete
720		Outer wire pitch assembly
701		
722	5328445	Cross recessed round head screw M6x12
723		Acorn nut M6
724		Cross recessed head tapping screw 4.2mm x 13mm
725	5328443	



# Assist Tower R980DP

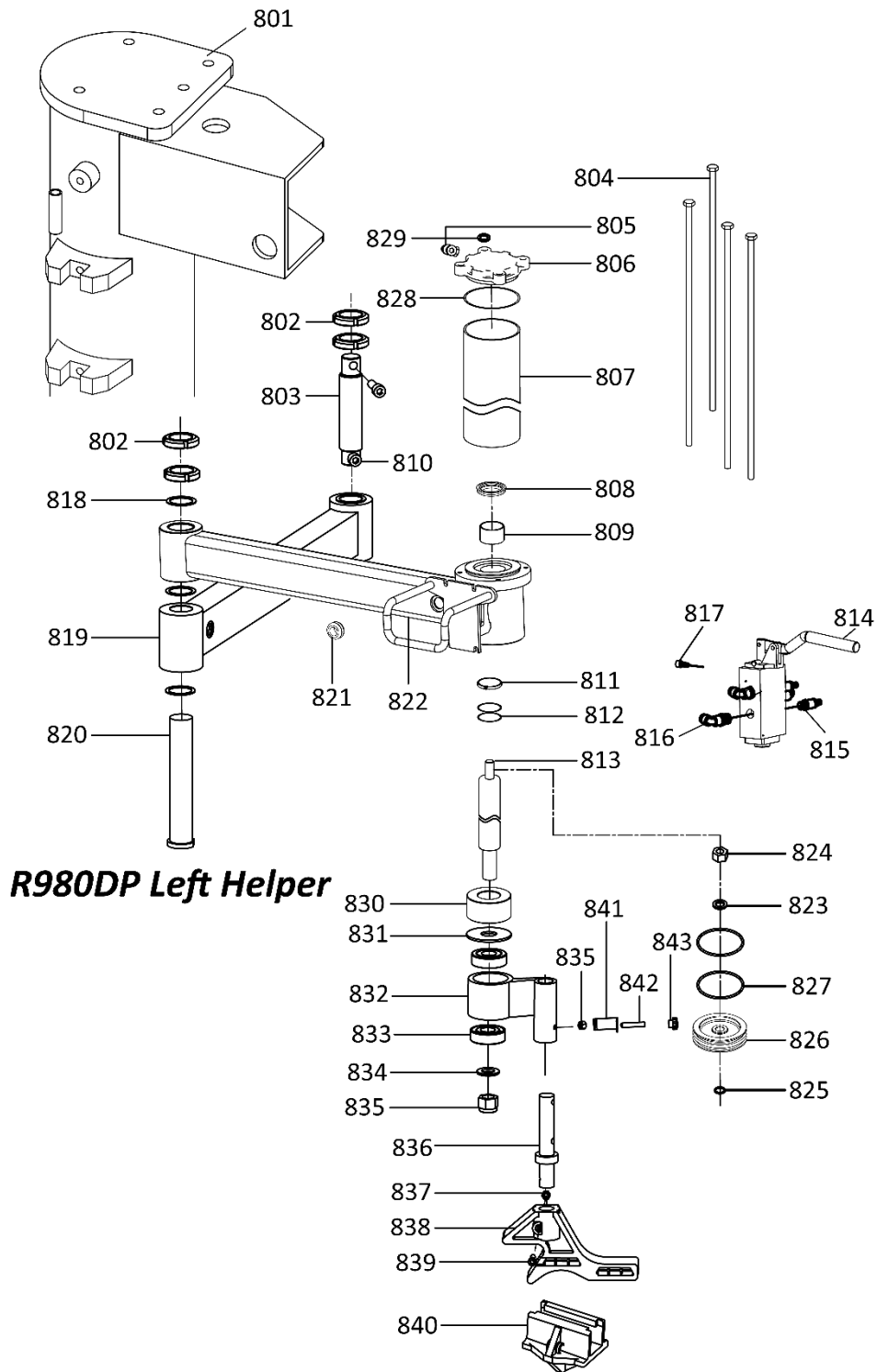

<b>Number</b>	<b>Part Number</b>	<b>Description</b>
801		Tower Unit Weldment
802		Nut
803		Connecting Shaft
804		Cylinder connecting bolt
805	5401427	Union G 1/8" elbow
806		Cylinder cover top
807		Cylinder block
808		Dust ring
809		Oil Bearing
810		SHCS M10 x 45
811		Cylinder Wear Strip
812		O-ring
813		Cylinder Rod
814		Ejector Valve
815		Silencer G 1/4"
816		Snap Ring
817		SHCS
818		Washer
819		Swivel arm assembly welds
820		Boom shaft
821		Overwinding
822		Swivel Arm assembly welds
823		Washer
824		Locknut
825		O-ring
826		Aluminum Plug
827		O-ring
828		O-ring
829		Washer, spring
830		Spacer
831		Washer
832		Tire Press Assy Welds
833		TRB
834		Washer
835		Locknut
836		Tire pressure lever
837		Nut
838		Pressure head
839		SHCS M6 x 30
840		Block
841		Movable shaft stopper
842		Movable shaft positioning pin
843		Movable shaft dowel knob

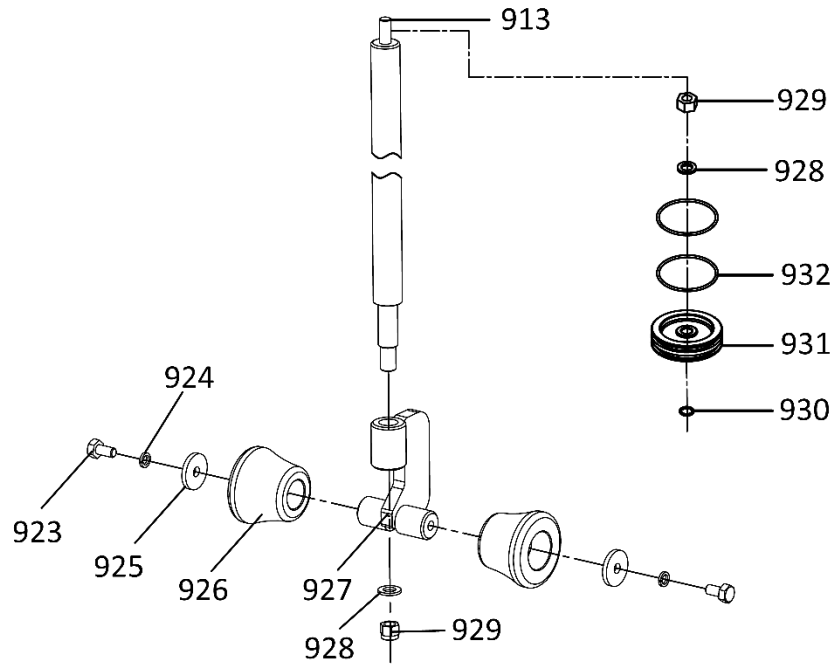
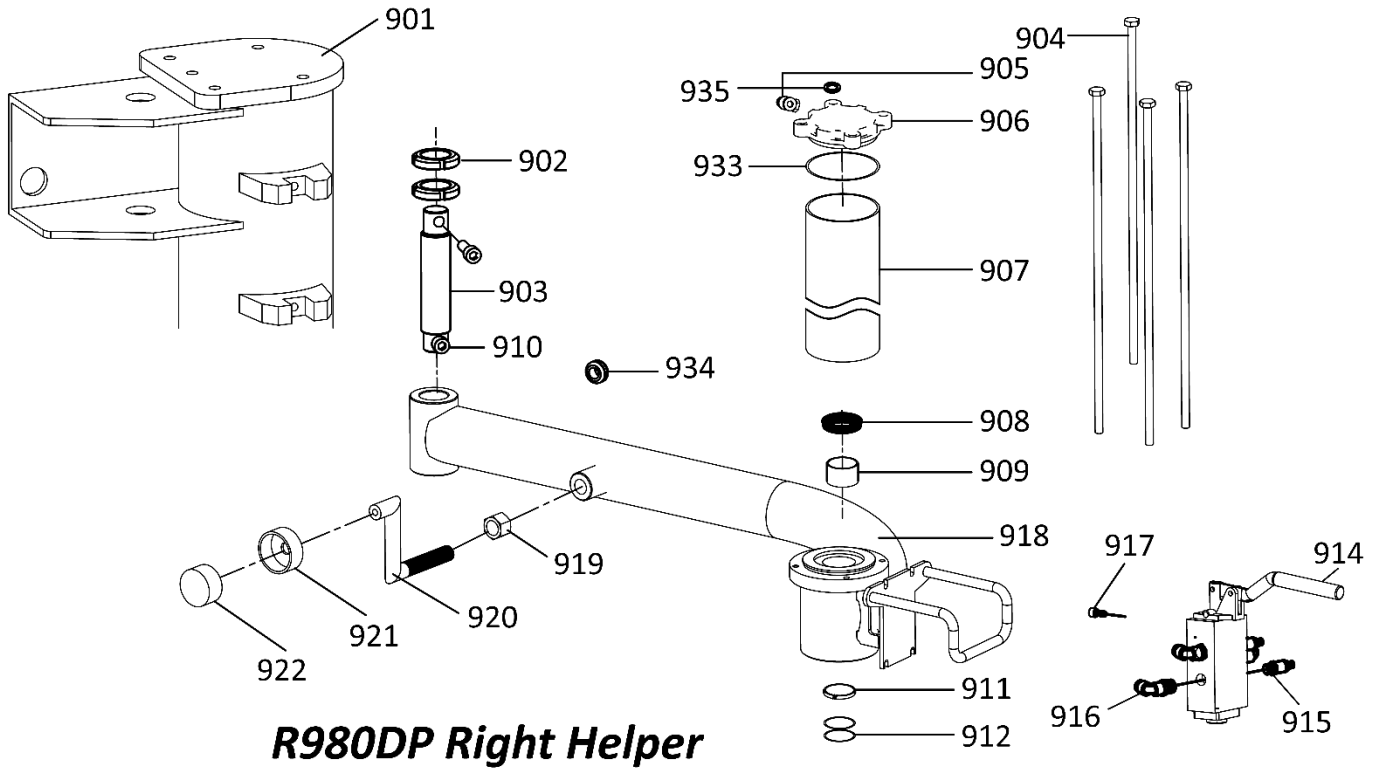

<b>Number</b>	<b>Part Number</b>	<b>Description</b>
901		Tower Unit Weldment
902		Nut
903		Connecting Shaft
904		Cylinder connecting bolt
905	5401427	Union G 1/8" elbow
906		Cylinder cover top
907		Cylinder block
908		Dust ring
909		Oil Bearing
910		SHCS M10 x 45
911		Cylinder Wear Strip
912		O-ring
913		Cylinder Rod
914		Ejector Valve
915		Silencer G 1/4"
916		Union G 1/4"
917		SHCS
918		Swivel arm assembly welds
919		Nut
920		Limit column assembly welds
921		Cushion collar
922		Rubber cushion
923		Hex Head Bolt, (HHB)
924		Locknut
925		O-ring
926		Aluminum Plug
927		O-ring
928		O-ring
929		Washer, spring
930		Spacer
931		Washer
932		Tire Press Assy Welds
933		TRB
934		Washer
935		Locknut
936		Tire pressure lever
937		Nut
938		Pressure head
939		SHCS M6 x 30
940		Block
941		Movable shaft stopper
942		Movable shaft positioning pin
943		Movable shaft dowel knob

## Inflation Foot Pedal

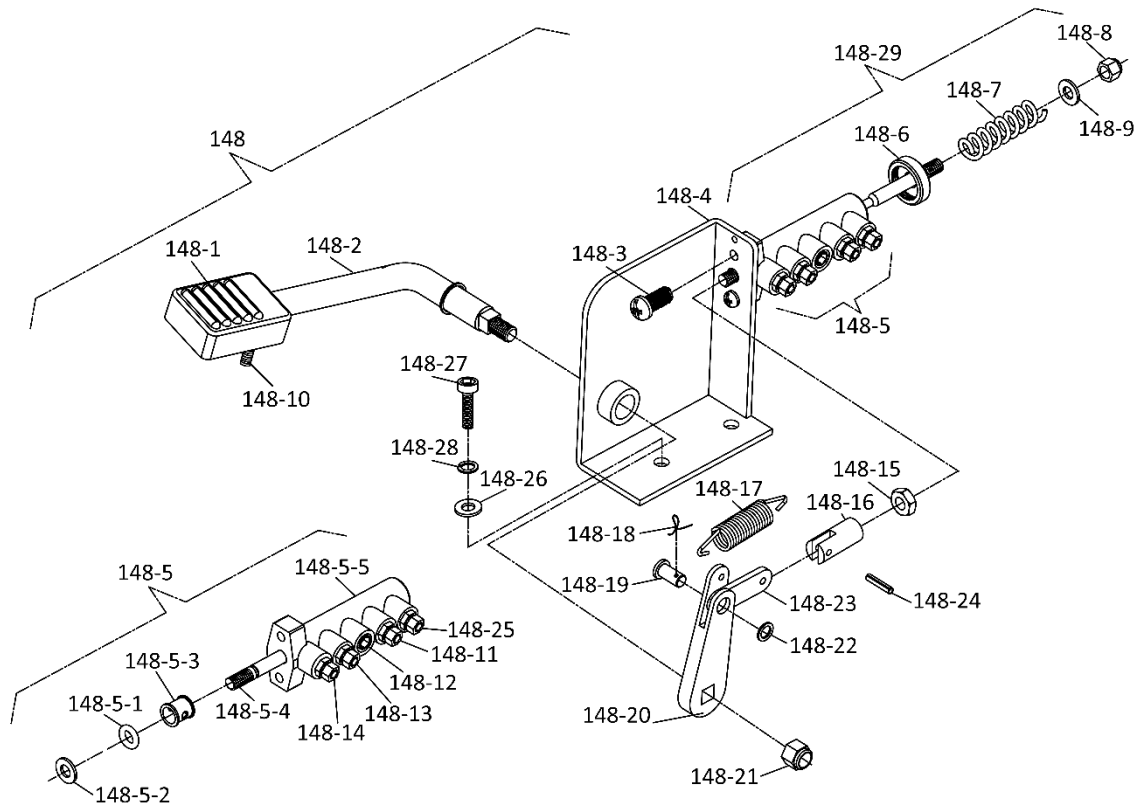

Number	Part Number	Description
148		Inflation foot pedal assy
148-1	5327178	Plastic foot pedal cover
148-2	5327670	Inflation foot pedal lever
148-3		Cross recessed round head screw M6 x 12
148-4		Pedal valve unit weldment
148-5		Bead blaster valve assembly
148-5-1	5327821	O-ring $\phi 15.4 \times 3.9$
148-5-2		Air valve end cap $\phi 15 \times 1.2$
148-5-3	5327820	Air valve O-ring spacer
148-5-4		Bead blaster valve lever
148-5-5	5327323	Air Valve Body
148-6		Air valve reinforce pad
148-7		Pressing spring
148-8		Locknut M8
148-9		Washer $\phi 8$
148-11		Fitting, G 1/8" 8 mm
148-12		Block G 1/8"
148-13		Fitting, G 1/8" 8 mm
148-14		Fitting, G 1/4" 8 mm
148-15		Nut M8
148-16	5327374	Foot Pedal Link; I Models
148-17	5327669	Inflation Foot Pedal Spring

---

148-18		Cotter pin
148-19		Pin $\phi 8$
148-20		Inflation foot pedal lever link
148-21	5400457	Nut M10 x 1.5 NL
148-22		Washer $\phi 8$
148-23		Foot pedal
148-24		Open straight pin $\phi 4 \times 18$
148-26		Washer $\phi 8$
148-27		Socket head cap screw M8 x 20
148-28		Washer $\phi 8$
148-29		Inner hexangular set screw M6 x 10



---

***Ranger***®

30440 Agoura Road  
Agoura Hills, CA 91301 USA  
(805) 253-2363  
[bendpak.com](http://bendpak.com)