



A Division of **TUXEDO** Distributors, LLC.

Paint Spray Booths

Model # PSB-SDD26B-AK

Detailed BOM List &

Assembly Detail Diagrams

(PSB-SDD26B-AK) FLOOR PLAN & ELEVATION DIMENSIONS

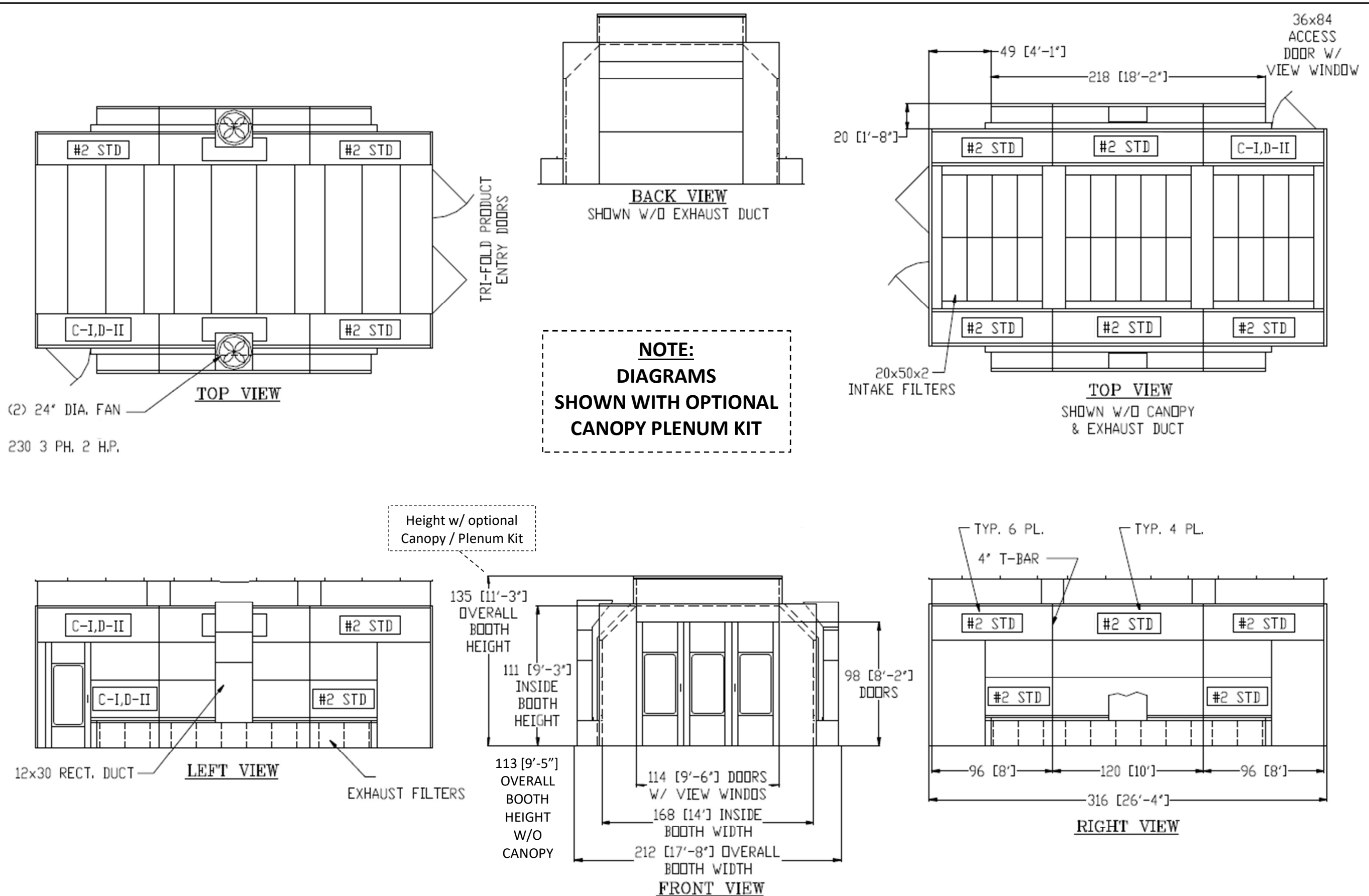

(PSB-SDD26B-AK) ISOMETRIC VIEW / RIGHT SIDE

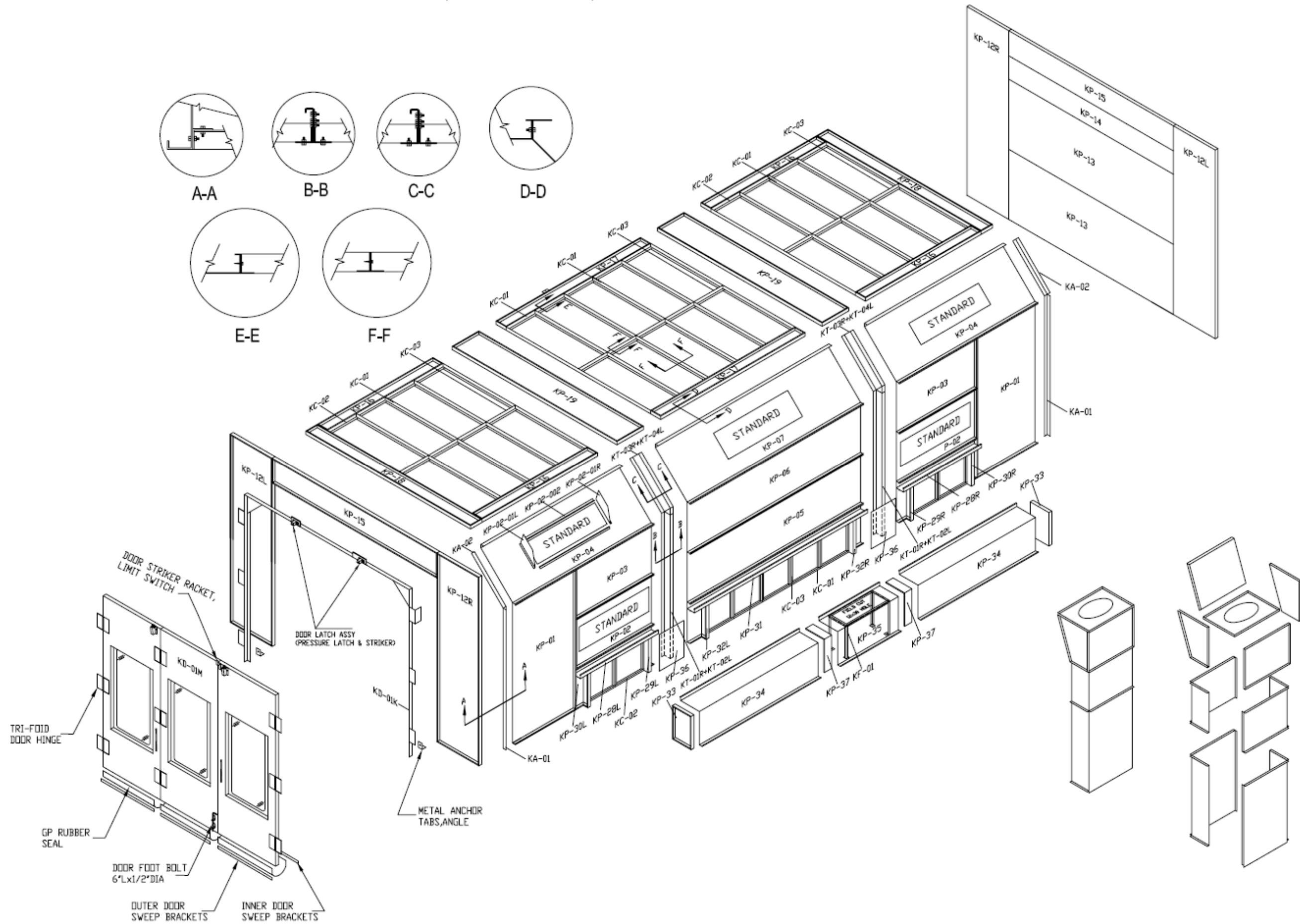

(PSB-SDD26B-AK) LEFT SIDE

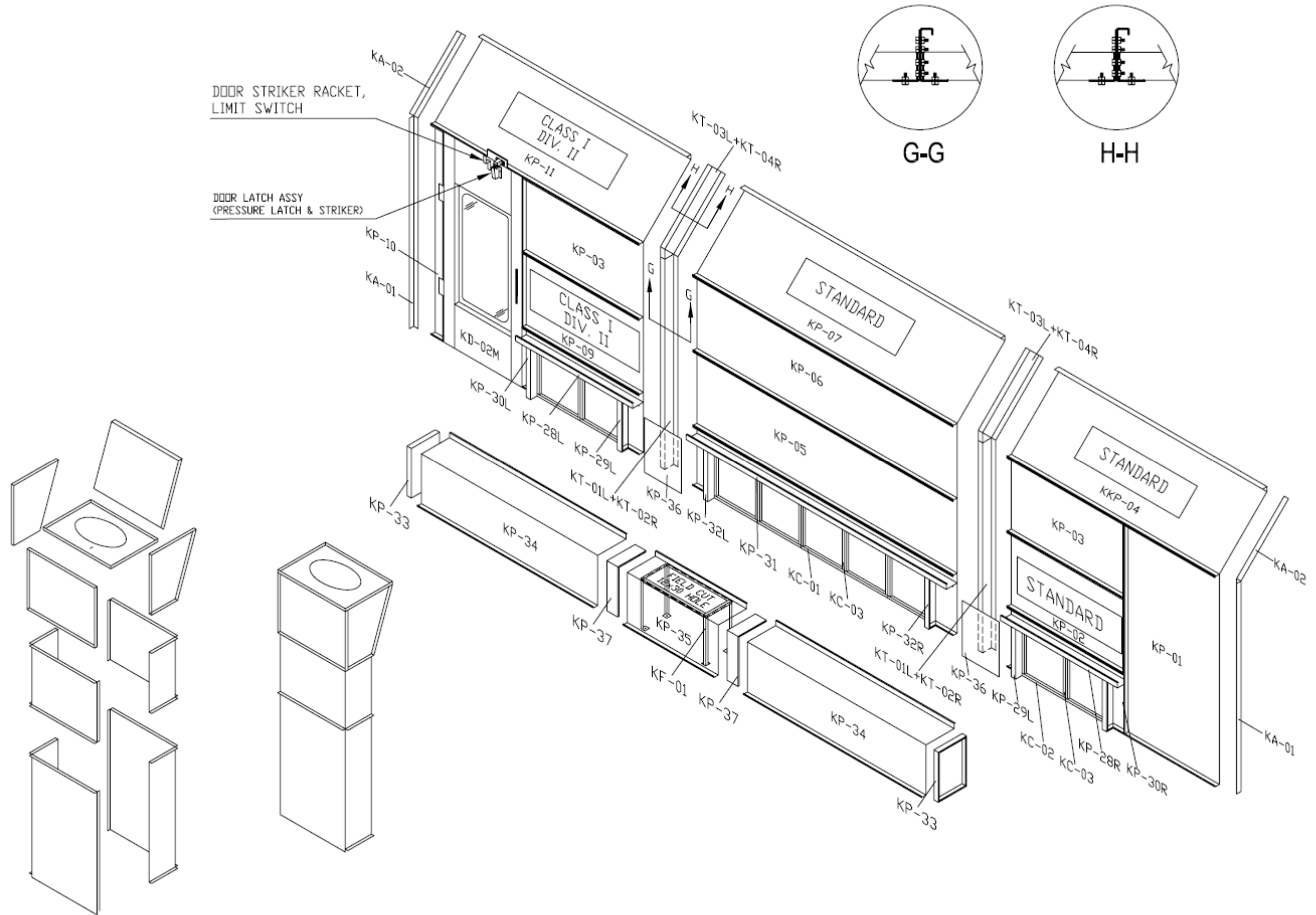

(PSB-SDD26B-AK) T-BAR ASSEMBLY DETAILS

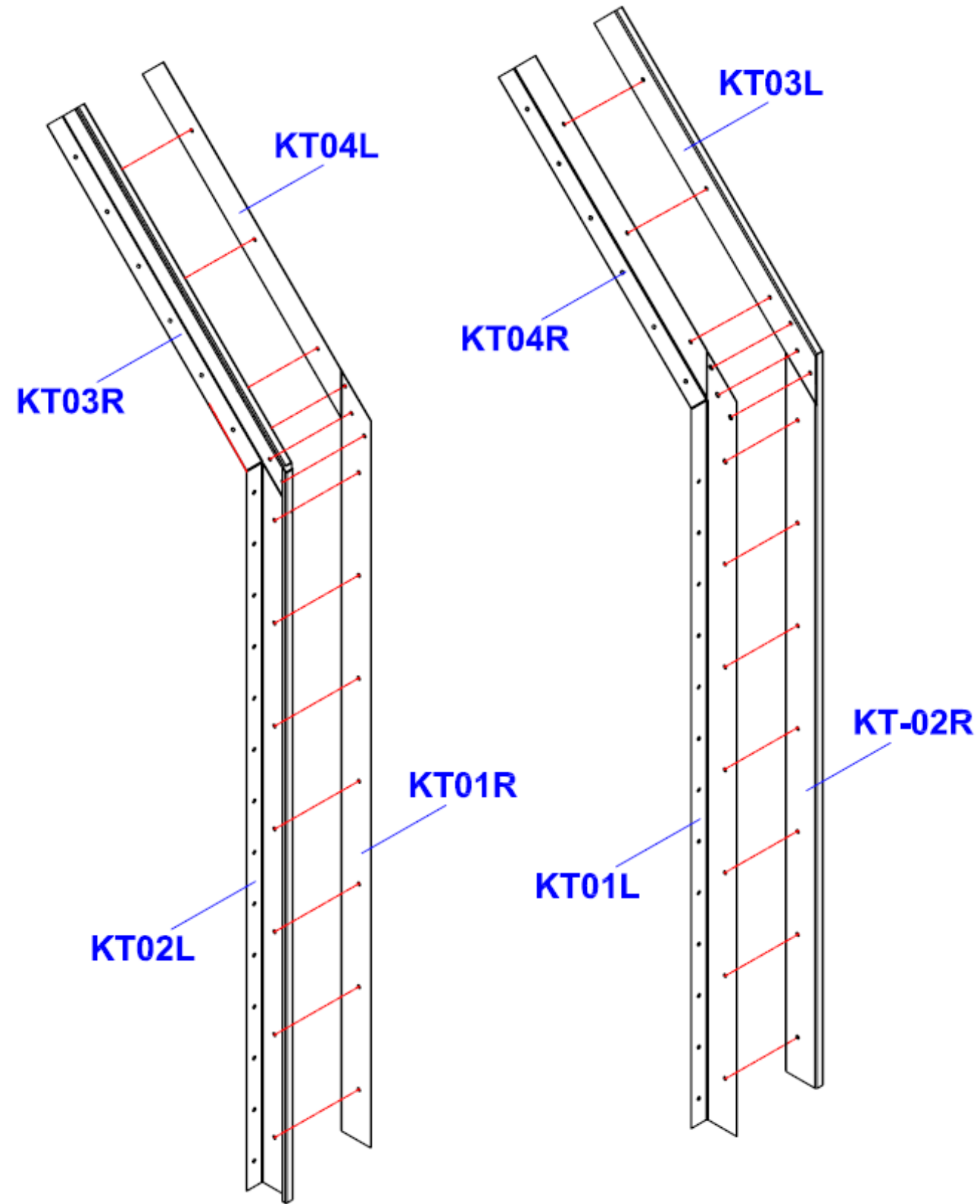

(PSB-SDD26B-AK) INTAKE FILTER GRIDS

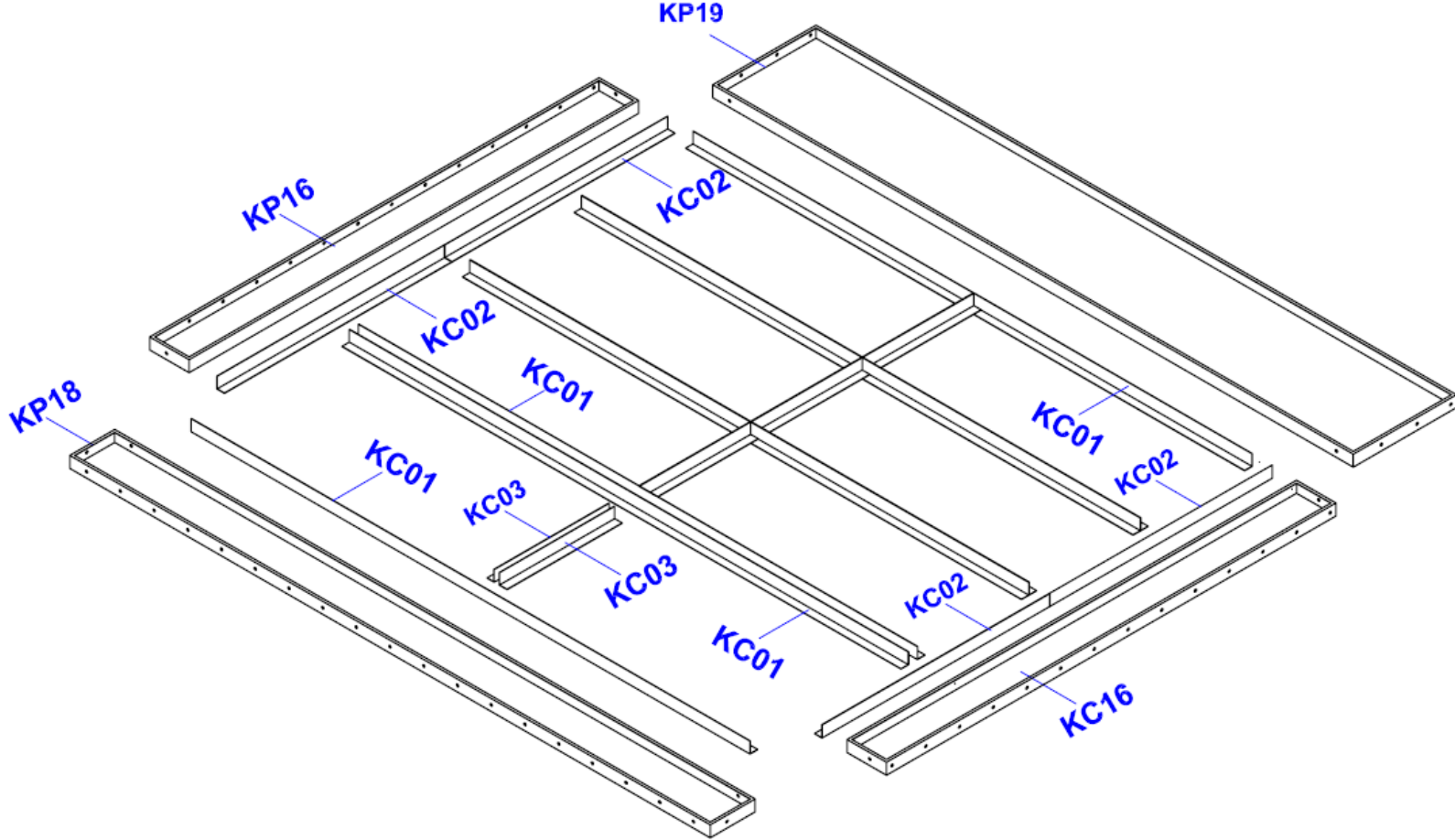

Small Intake Filter Grid – End Sections

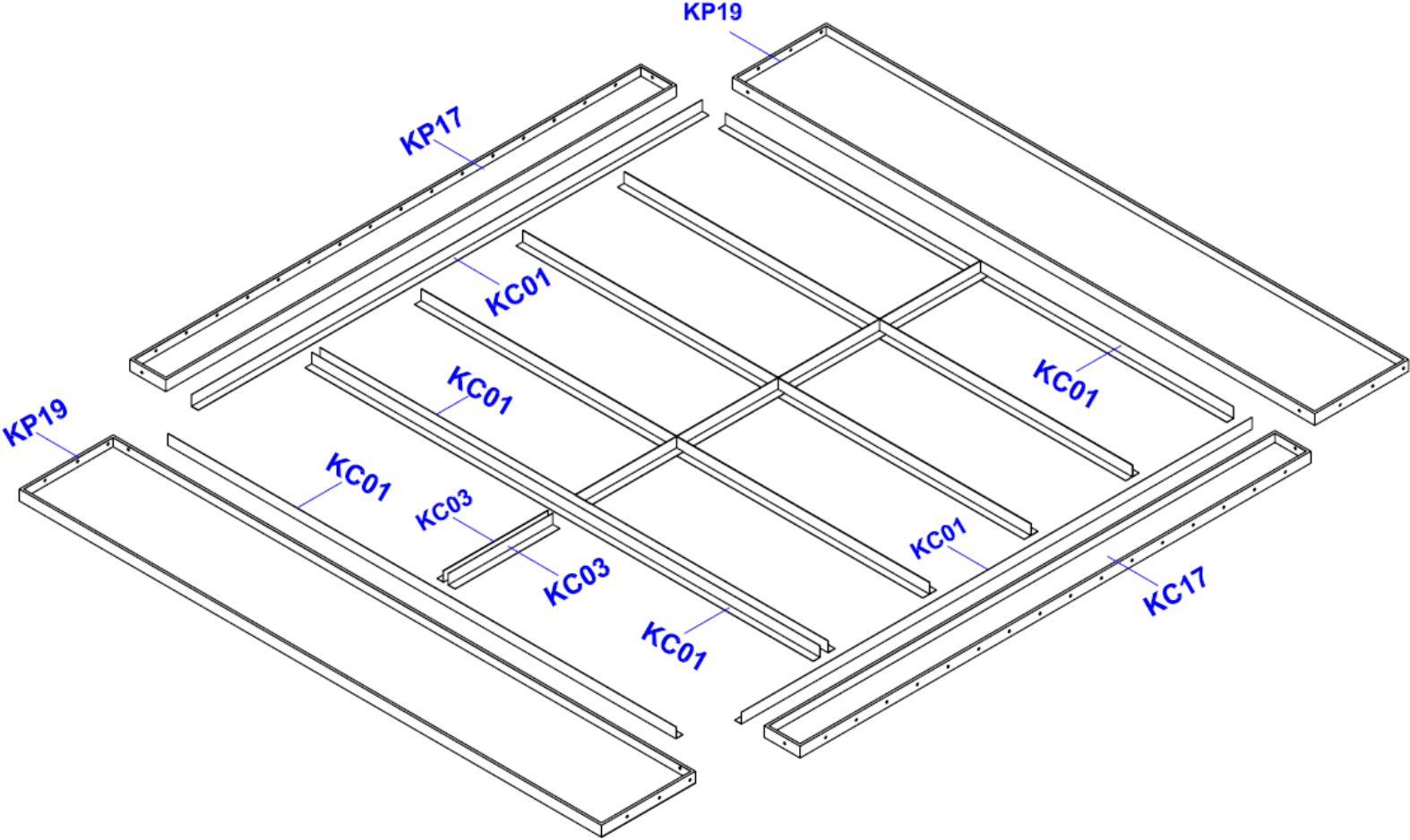

Large Intake Filter Grid – Center Section

(PSB-SDD26B-AK) EXHAUST FILTER GRIDS

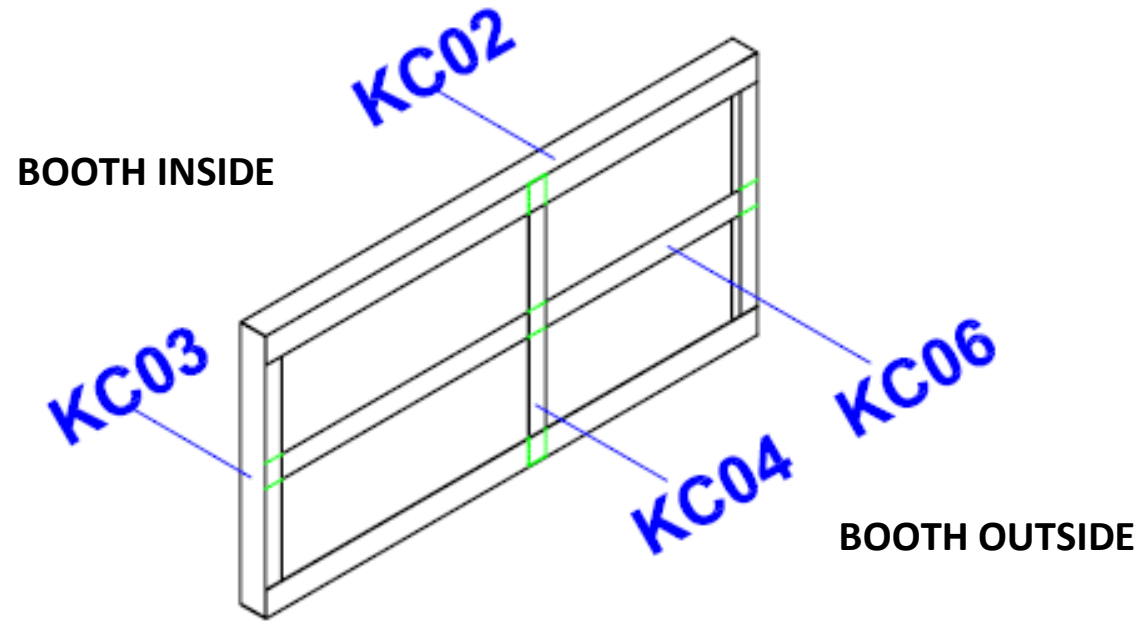

Small Exhaust Filter Grid – End Sections

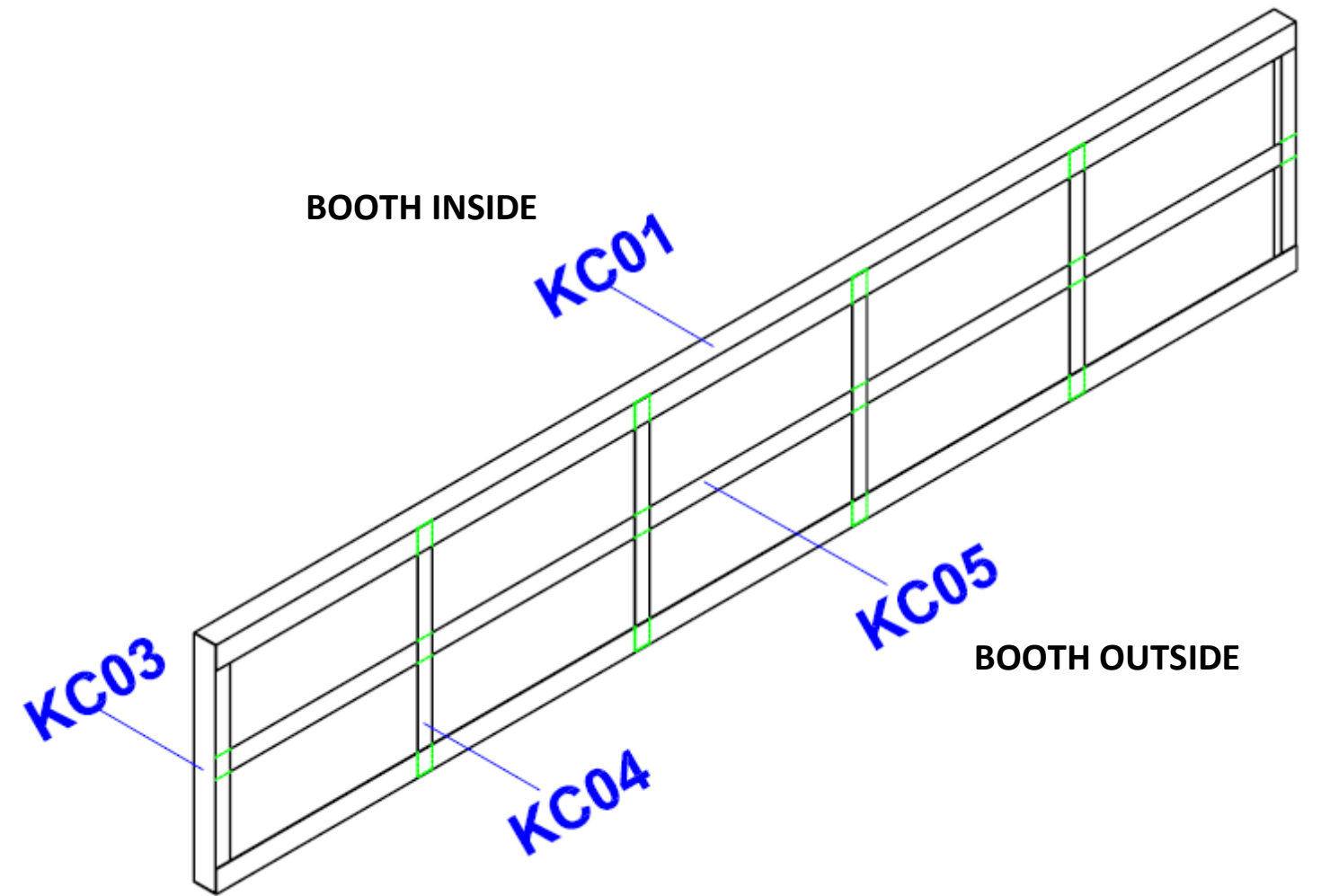

Large Exhaust Filter Grid – Center Sections

(PSB-SDD26B-AK) – SDD EXHAUST CHAMBER

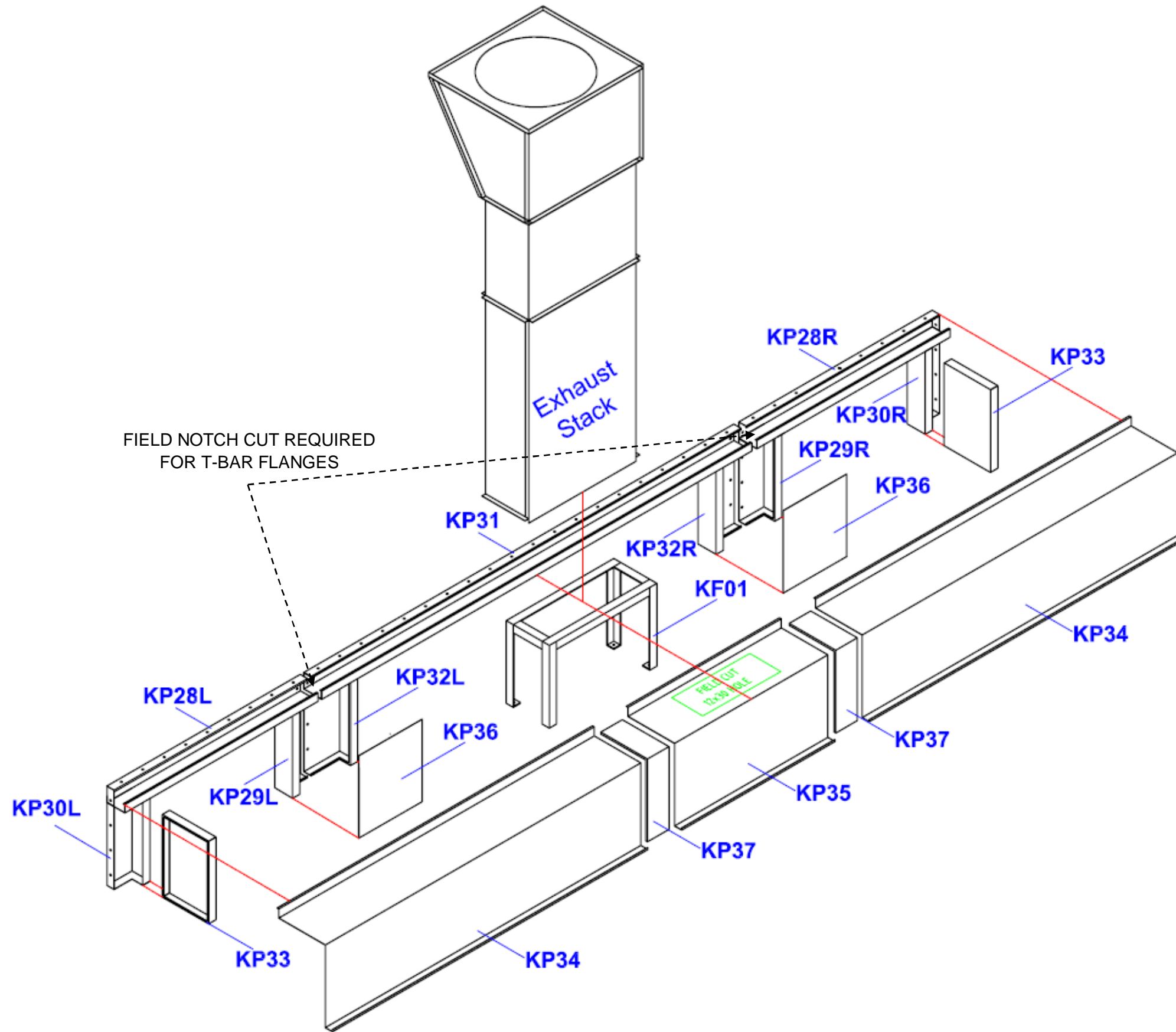

(PSB-SDD26B-AK) – SDD EXHAUST CHIMNEY STACK ASSEMBLY

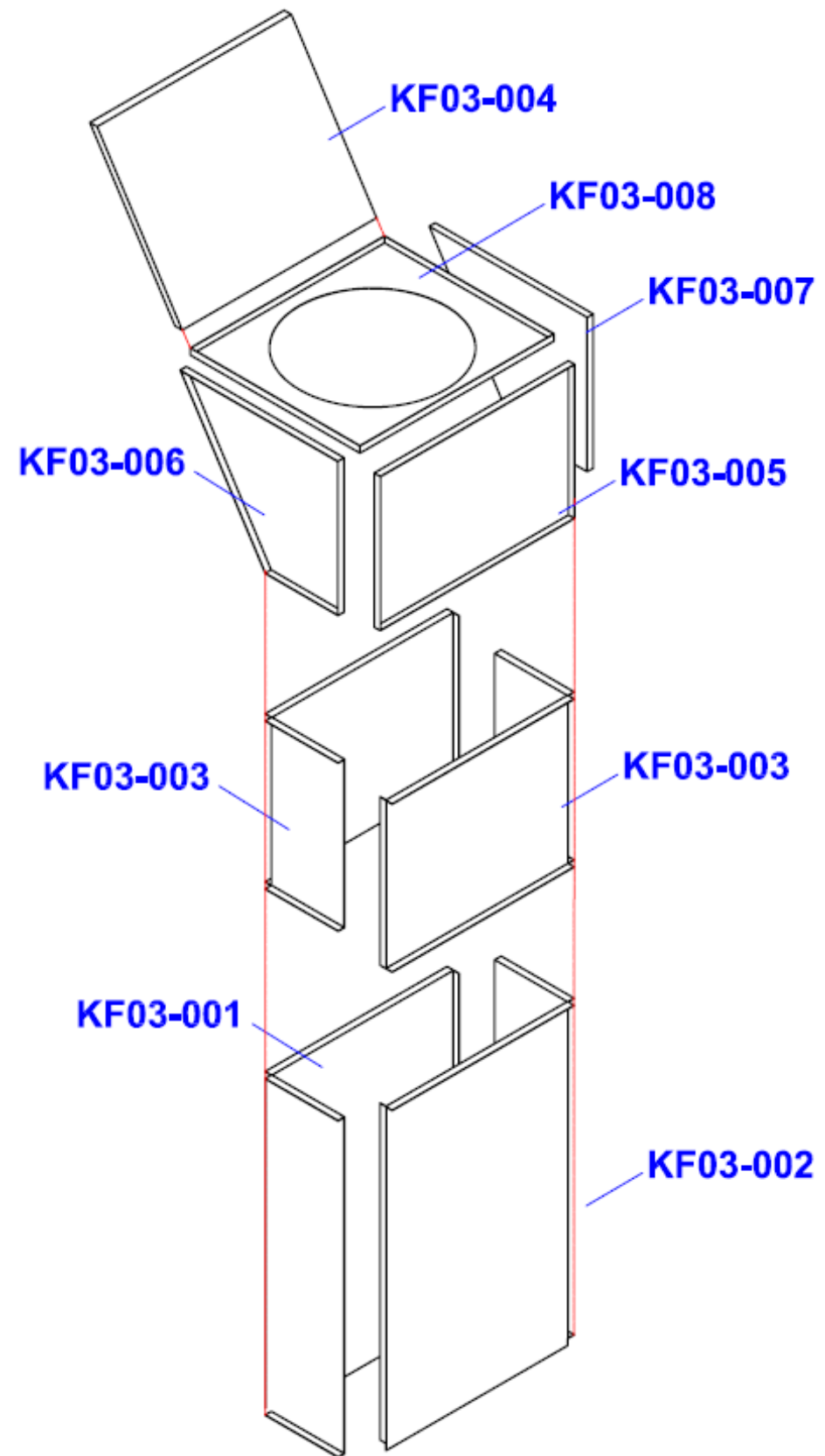

(PSB-SDD26B-AK) – STANDARD LIGHT FIXTURE ASSEMBLY

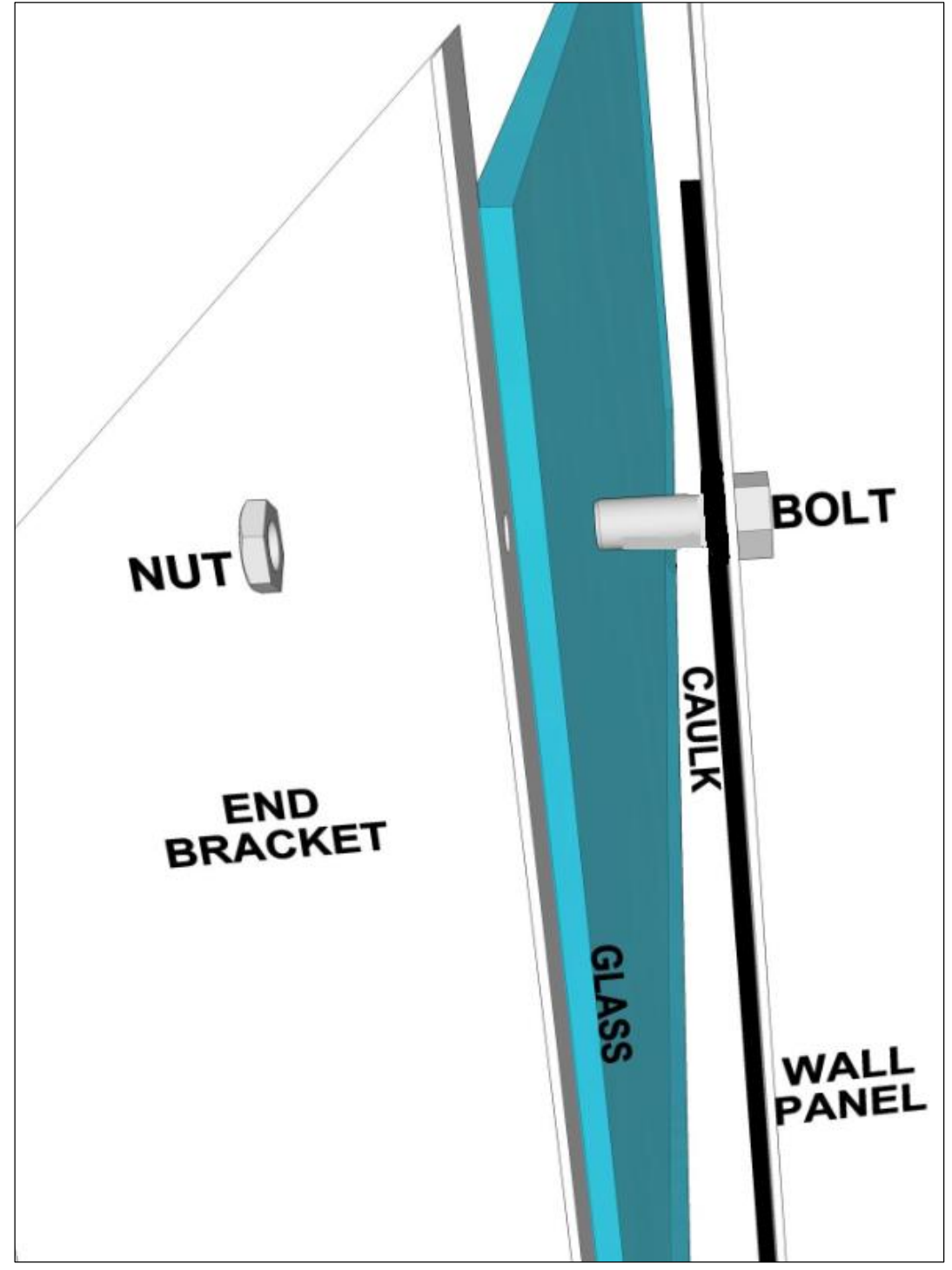
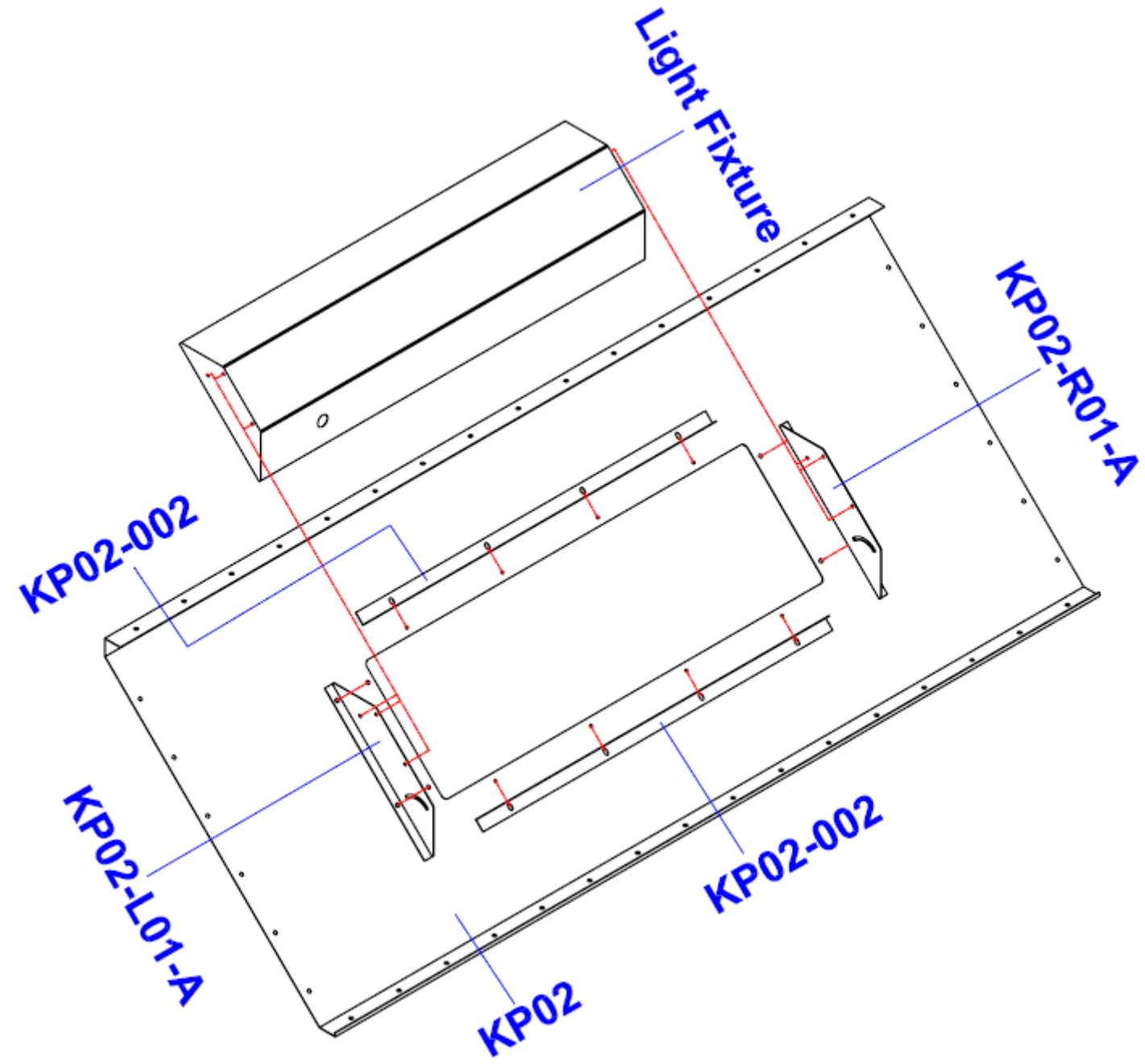

(PSB-SDD26B-AK) – TRIFOLD PRODUCT DOOR ASSEMBLY (A)

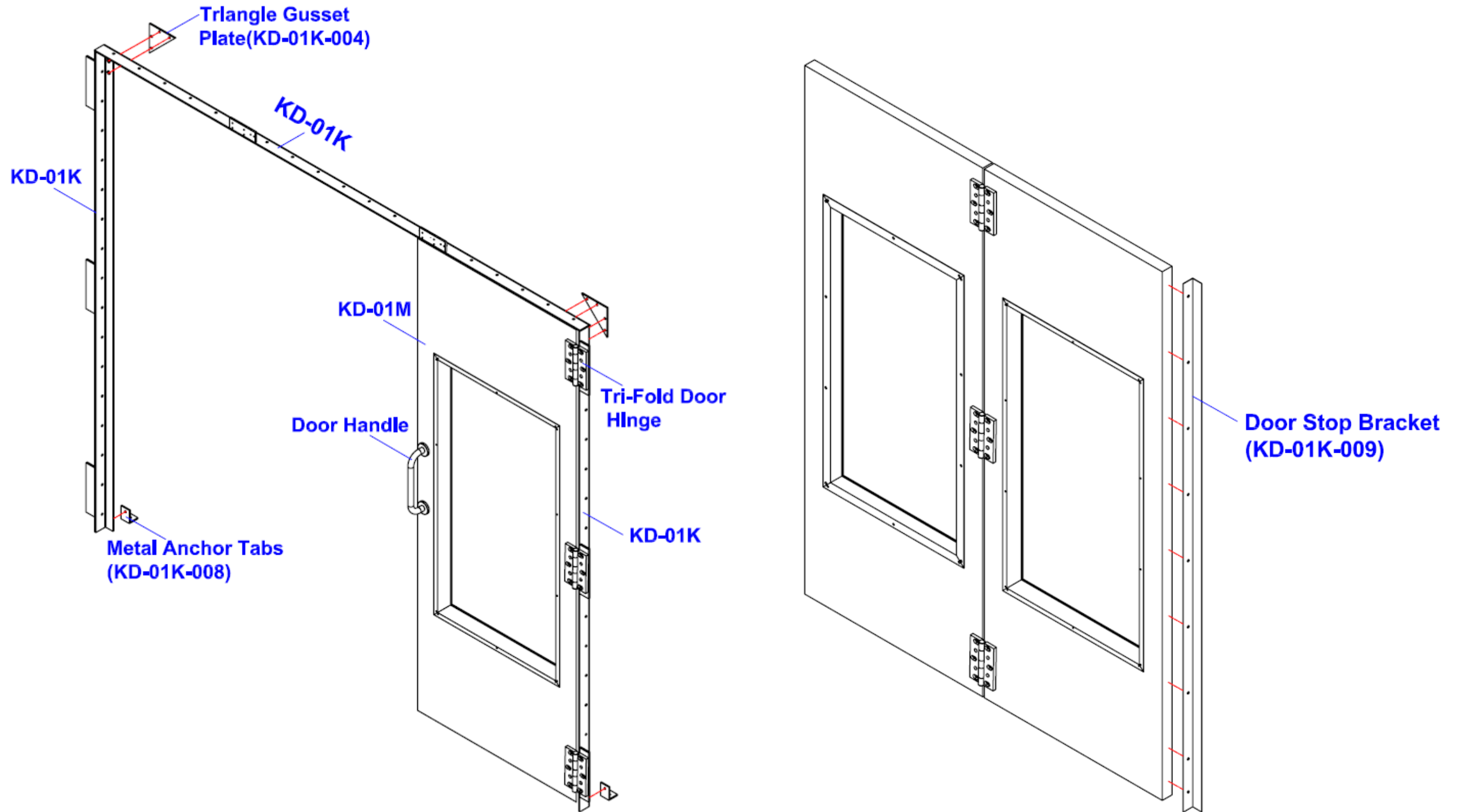

(PSB-SDD26B-AK) – TRIFOLD PRODUCT DOOR ASSEMBLY (B)

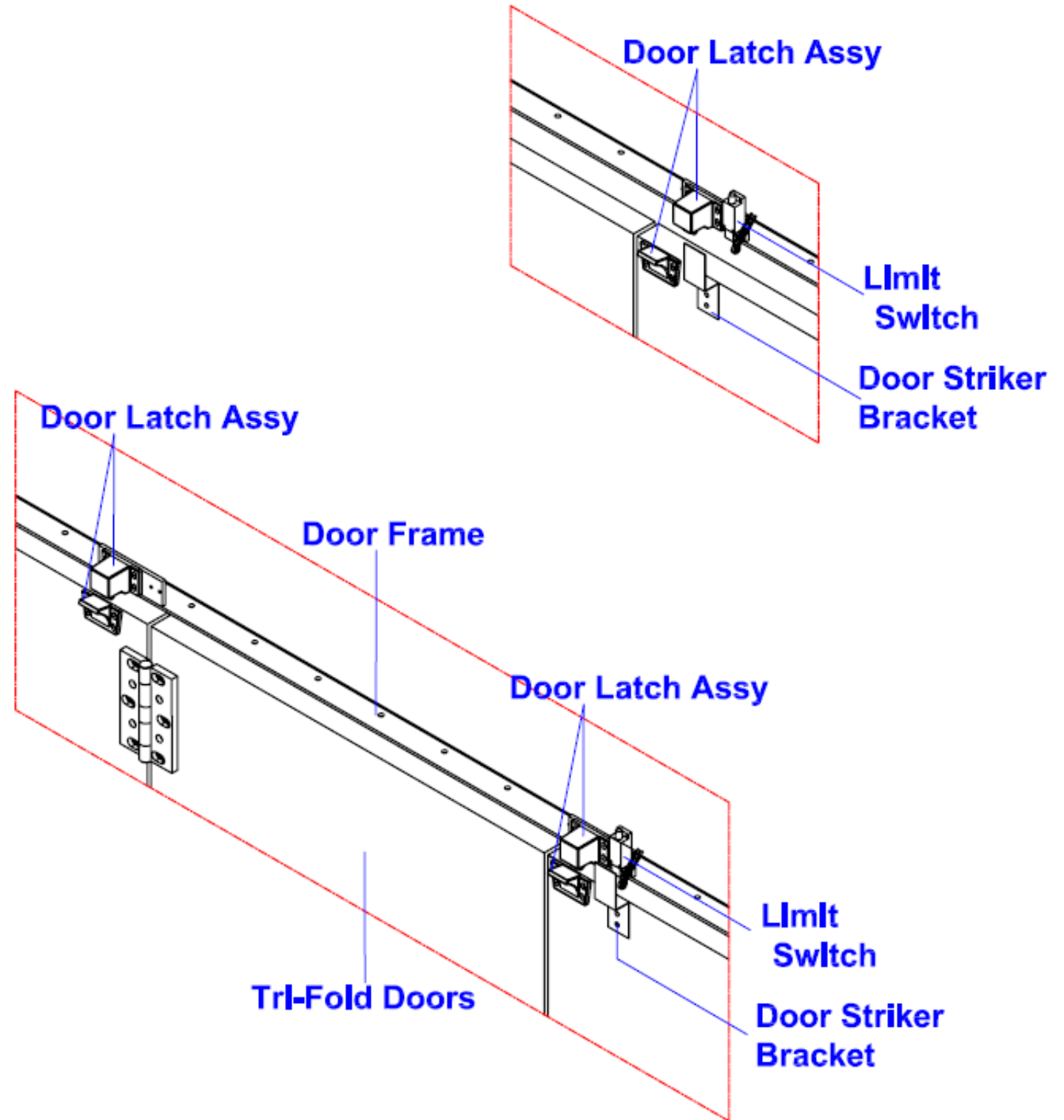
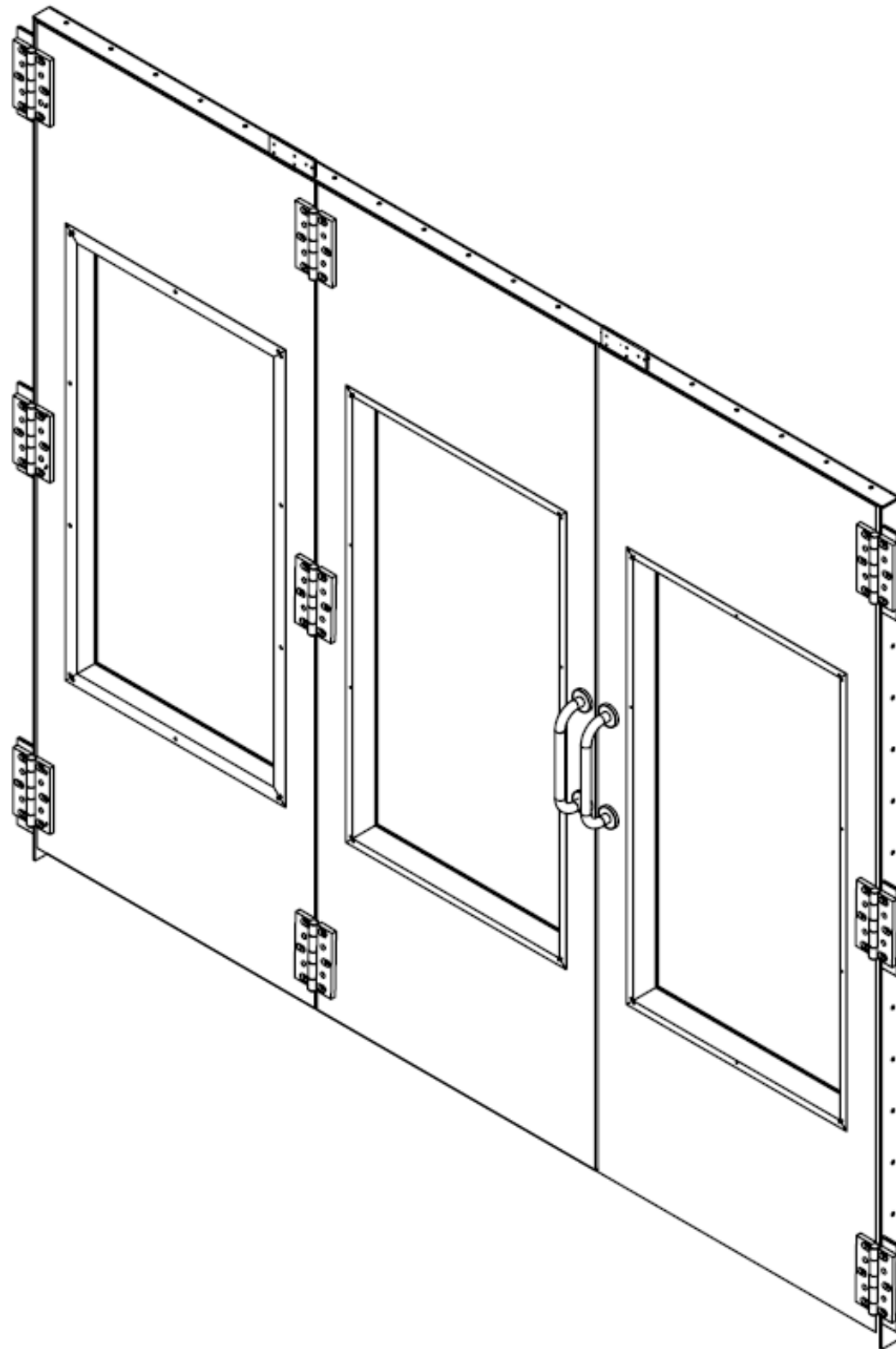

(PSB-SDD26B-AK) - DOOR SWEEP DETAIL

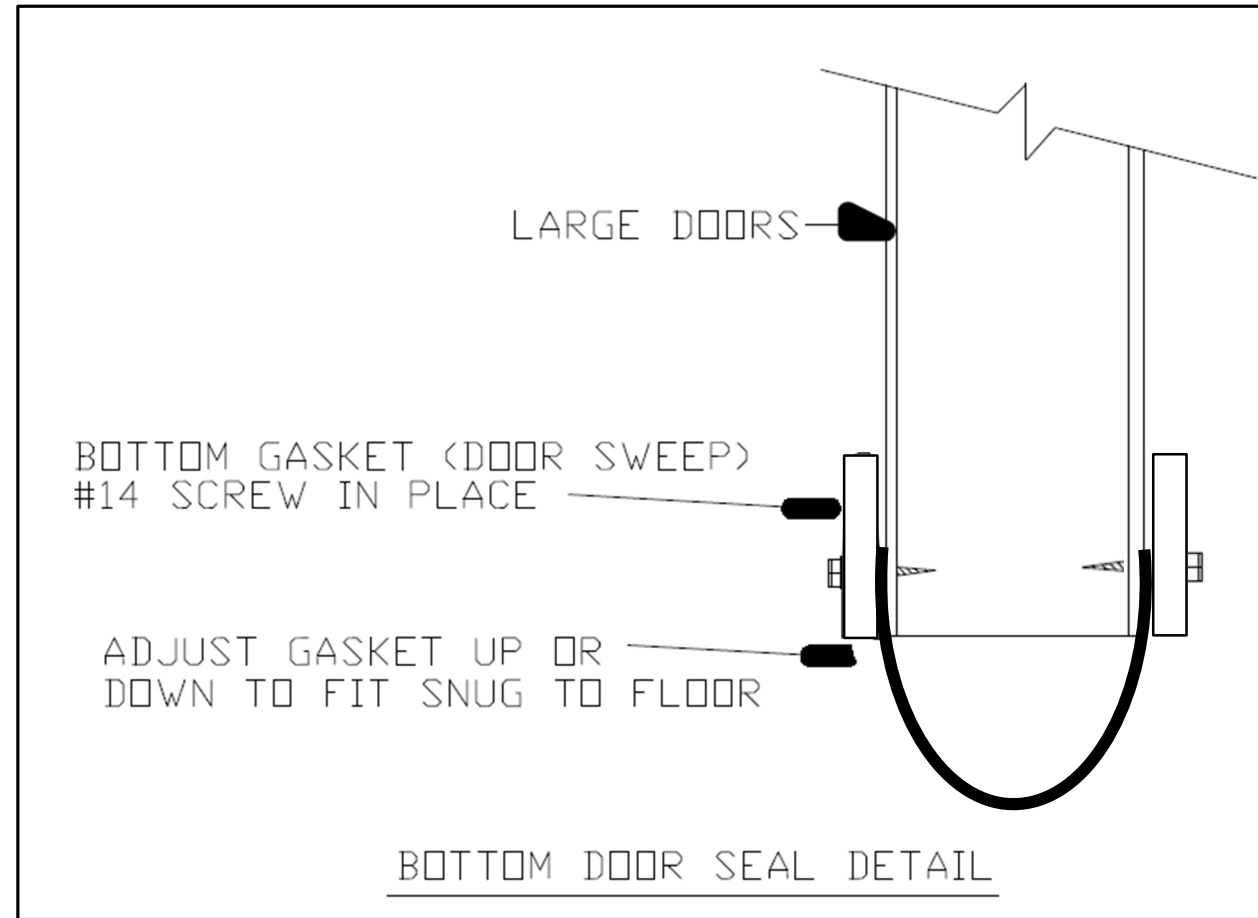

(PSB-SDD26B-AK) - FRONT/REAR WALL DETAIL

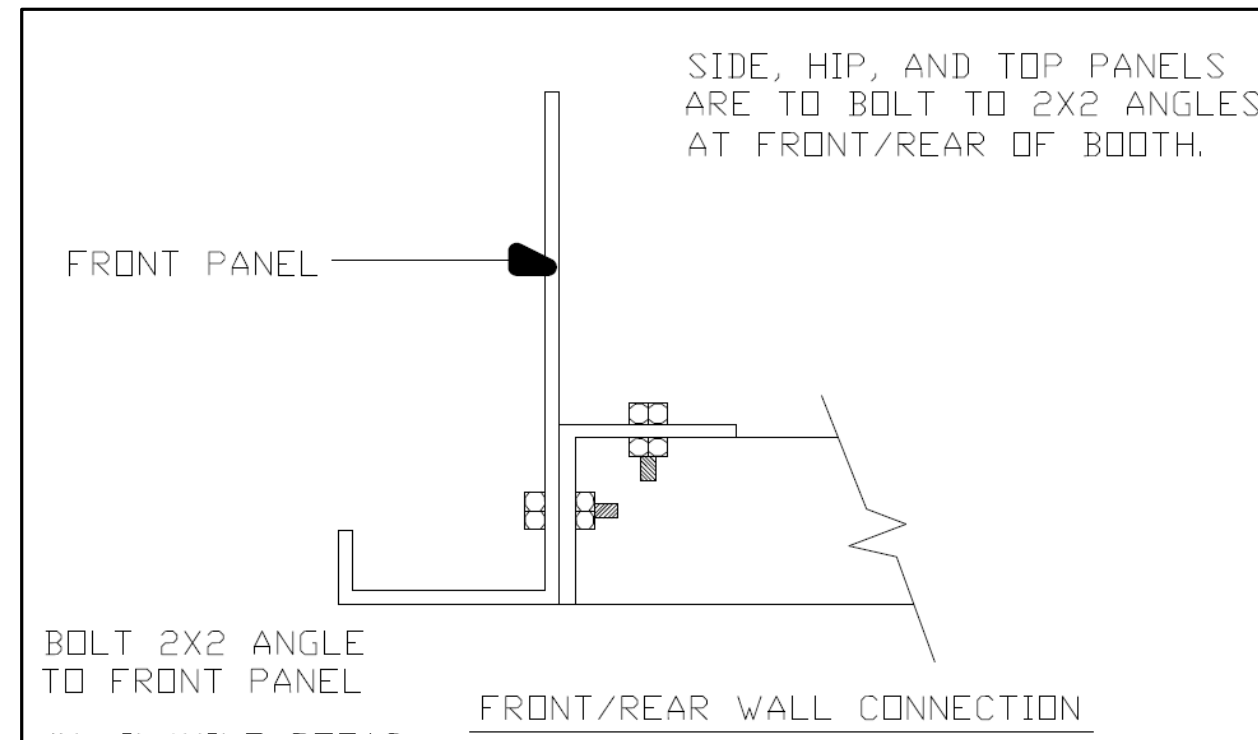

(PSB-SDD26B-AK) – PANELS TO T-BAR DETAIL

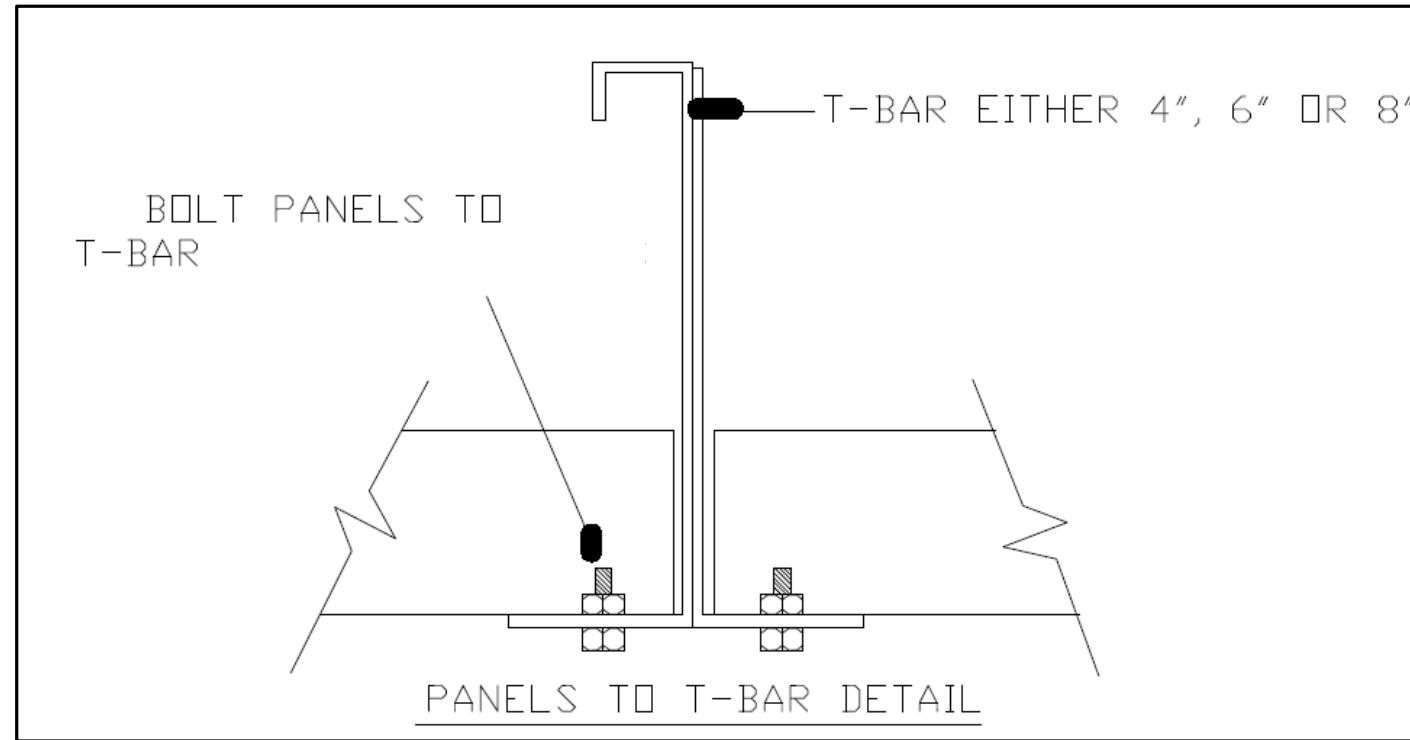

(PSB-SDD26B-AK) - FILTER CELLS TO ROOF PANEL DETAIL

