

# 2 TON Capacity Hydraulic Transmission Jack

This jack is designed for transmission and installation of automobile and light truck component parts. The instructions must be carried out conscientiously in order to operate the jack safely and properly.

## 1. Operating Procedure:

1.1 Exhausting: During shipment and handling, especially after a long storage, air probably gets into the hydraulic system, causing poor lifting performance. So exhaust any air from the system before use. Here follow the methods.

1.1A. Close release valve (turn knob clockwise as shown) . Loosen the air vent plug on the filler, then operate handle until the empty saddle gets to the highest.

1.1B. Open the release valve (turn knob counterclockwise). While holding the empty saddle down, operate handle rapidly several times in order to exhaust the air in the system, then press the air vent plug tightly.

## 1.2 Lifting:

1.2A. Turn the knob clockwise until release valve closes. Do not overtighten the valve.

1.2B. please place jack directly and centrally under object to be lifted. Operate the handle up and down within an angle of 60°. The jack can take up load immediately.

While lifting very heavy objects, the angle to operate handle must be within the limits of 45° so as to avoid damaging parts with the rapid increase of the operating force. (full 360° rotating pump handle operates in any position)

1.2C. After raising jack to required height: use jack stand to hold load.

## 1.3 Transmission:

1.3A. Fix load tightly on the saddle with chains.

1.3B. Turn the release valve counterclockwise in order to lower the load to lower position ( About at the midpoint of the whole lifting height).

1.3C. The four handlebars on jack ( as shown in the diagram) are used to move jack in any direction on level solid surfaces.

1.4 Saddle Adjusting: For safe and proper use, the saddle can be adjusted according to the load size and angle degrees while disassembling ( As shown in the diagram).

1.4A. Loosen the four bolts on saddle, adjust the four retaining plate ass'y parts to proper position, then twist bolts tightly. The saddle side adjustment is within the limits as shown in the specifications.

1.4B. Adjust the two regulating bolts on the saddle, then the saddle can be side titled within the limits as shown in the specifications. The two bolts must be adjusted simultaneously and harmoniously in order to let the saddle stay in required angle and not sway.

Turn the adjusting handwheel under saddle. Then the saddle can be titled within the limits from forward to back as shown in the specifications.

1.5 Lowering: Turn the knob counterclockwise until release valve opens. Saddle automatically lowers to its original position. Do not open the release valve too fast, or saddle will go down quickly and do damages to load.

1.6 Oiling: If jack needs re-oiling, please follow the methods below:

Take out the air vent plug, inject machine hydraulic oil into the plug. At the same time operate the handle for 3 to 5 times in order to guarantee the inner hydraulic system full of oil. When oil is on a level with the edge under the oil-filling hole, stop oiling and press the air vent plug tightly.

2. Maintenance instruction:

2.1 Before operating the jack, lubricate points (1) to (5) indicated in the diagram.

2.1A. Wheels: Use light oil on axles and caster bearings.

2.1B. Saddle and linkages: Use light oil on all moving pivoting parts.

2.1C. Lifting arm: Inject grease into moving parts.

2.1D. Handle: Use light oil on moving parts.

2.1E. Linkage between handle and plunger: Use grease to lubricate it.

2.2 Check the hydraulic system: every 4 months to make sure it is free from corrosion. If corrosion is present, clean the parts and remove rust, then re-oil according to the above-mentioned oiling method. Always use good quality hydraulic jack oil. Do not mix the type of oil. When filling with hydraulic oil do not permit dirt or any other substance to enter the hydraulic system.

2.3 Always store the jack with saddle fully Lowered and with release valve open.

3. Cautions:

3.1 Jack is designed for lifting purpose only. It must not be used as a jack stand to hold load for any prolonged period.

3.2 Do not move the jack when load is in very high position and is not fixed on saddle stably.

3.3 The jack should move only on a hard level surface.

3.4 Do not adjust safety valve. When necessary, return jack to service agent for any adjustment.

3.5 Do not overload and jack beyond its rated capacity.

3.6 Do not substitute component parts when jack model is different.

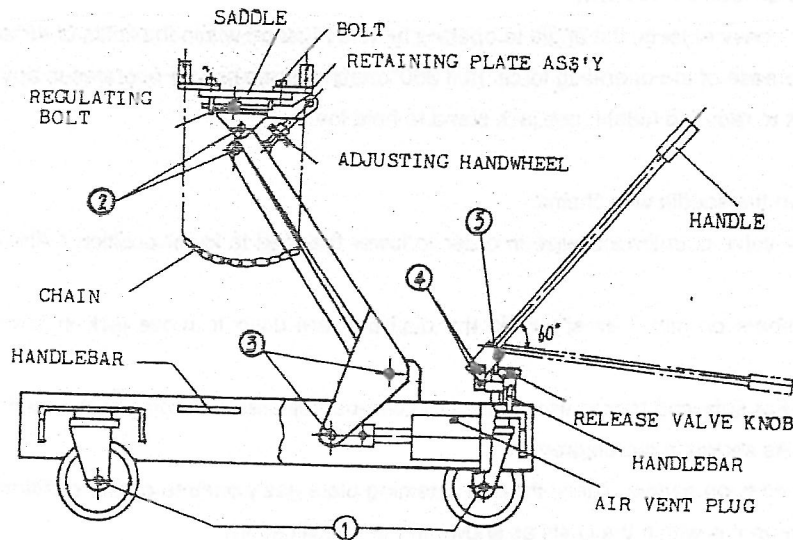

## SPECIFICATION

MODEL	CAP. (T)	LIFT RANGE		SADDLE SIZE ADJUSTMENT		CASTOR DLA. (mm)	CHASSIS SIZE		SADDLE TILT			NET WEIGHT (kg)
		LOW (mm)	HIGH (mm)	MIN. (mm×mm)	MAX. (mm×mm)		LENGTH (mm)	WIDTH(mm)	FWD. (°)	BACK (°)	SIDE (°)	
3180	2	230	890	320×190	420×290	100	1136	660	10°	10°	±10°	135

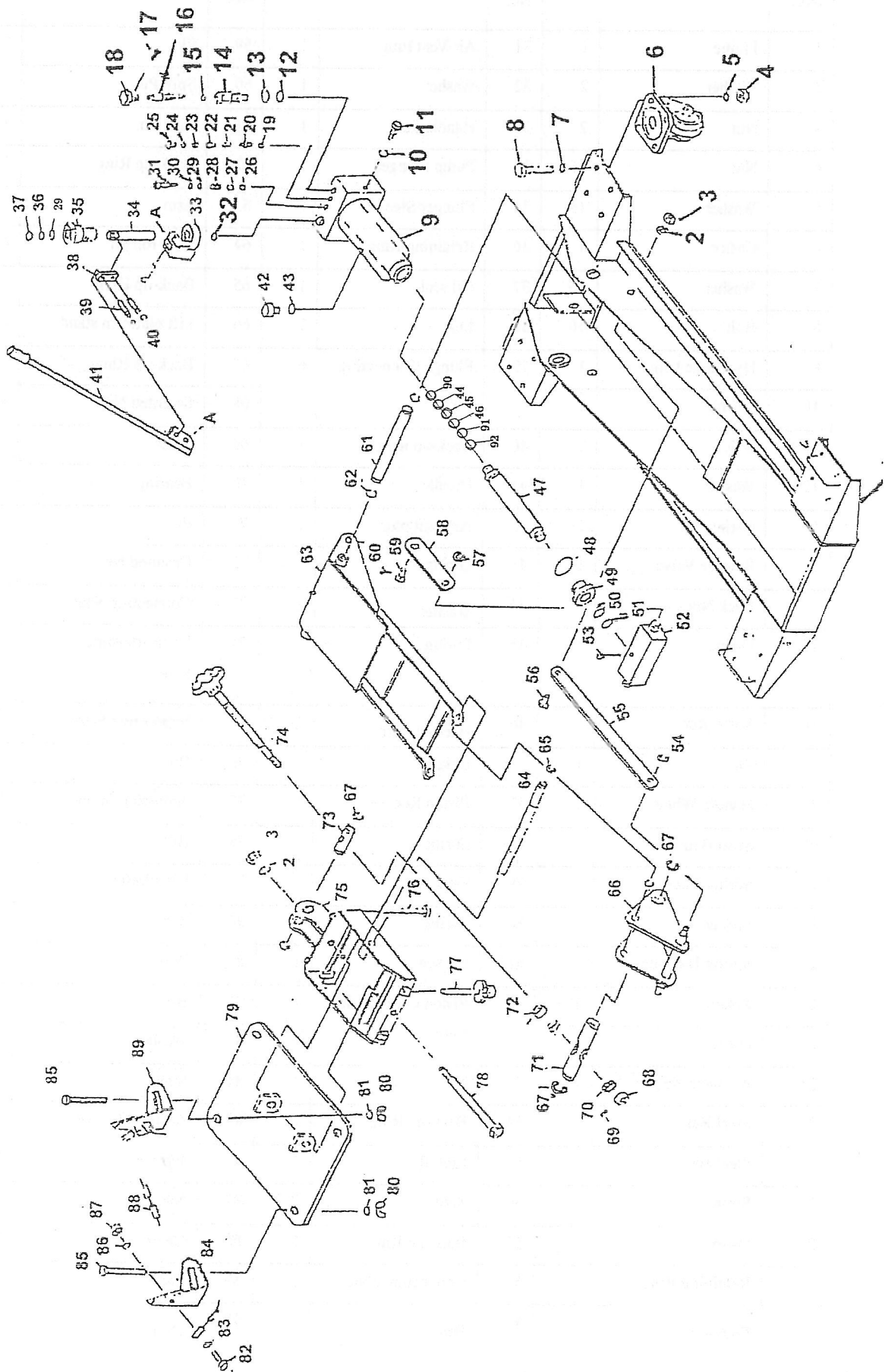

Part No.1	Description	Qty	Part No.	Description	Qty	Part No.	Description	Qty
1	Frame	1	31	Air Vent Plug	1	59	Pin	2
2	Washer	2	32	Washer	1	60	Split Pin	2
3	Nut	2	33	Handle Fork	1	61	Arm Pin	1
4	Nut	16	34	Pump Plunger	1	62	Back-up Ring	2
5	Washer	16	35	Plunger Sleeve	1	63	Arm	1
6	Castor	4	36	Retaining Ring	1	64	Link rod pin	4
7	Washer	16	37	Oil seal	1	65	Back-up Ring	1
8	Bolt	16	38	Lug	2	66	Lift platform stand	4
9	Hydraulic Unit	1	39	Plunge Connecting Pin	6	67	Back-up Ring	1
10	Washer	2				68	Oriented Nut	4
11	Bolt	2	40	Back-up Ring	1	69	Screw	2
12	Washer	1	41	Handle	1	70	Bearing	2
13	O-ring	1	42	Air vent plug	1	71	Pin	1
14	Release Valve	1	43	O-ring	1	72	Oriented Nut	1
	Lock Nut		44	Washer	1	73	Connecting Shaft	1
15	O-ring	1	45	O-ring	1	74	Long adjusting Screw	1
16	Valve Rod	1	46	Back-up ring	1	75	Supporting Stand	1
17	Pin	1		Retainer		76	Bolt	2
18	Handle Wheel	1	47	Piston Rod	1	77	Adjusting Screw	2
19	Steel Ball	1	48	O-ring	1	78	Bolt	1
20	Spring Back-up	1	49	Tank nut	1	79	Lift platform	1
21	Spring	1	50	O-ring	1	80	Nut	4
22	Spring Back-up	1	51	Oil seal	1	81	Washer	4
23	Retainer	1	52	Piston Connecting Joint	1	82	Bolt	2
24	O-ring	1				83	Washer	2
25	Air Vent Plug	1	53	Pin	1	84	Stand	2
26	Steel Ball	1	54	Back-up Ring	2	85	Adjustable screw	4
27	Steel Ball	1	55	Link Rod	2	86	Washer	2
28	Spring	1	56	Screw	2	87	Nut	2
29	O-ring	2	57	Back-up Ring	2	88	Chain	2
30	Retaining Ring	1	58	Connecting plate	2	89	Stand	2
90	Back-up ring	1	91	Bush	1	92	O-ring	1